

NIPPON THOMPSON CO., LTD. (JAPAN)

Head office : 19-13 Takanawa 2-chome Minato-ku
Tokyo 108-8586, Japan
Phone : +81 (0)3-3448-5850
Fax : +81 (0)3-3447-7637
E-mail : ntt@ikonet.co.jp
URL : <http://www.ikont.co.jp/eg>
Plant : Gifu, Kamakura

IKO-THOMPSON (SHANGHAI) LTD. (CHINA)

Shanghai Headquarters

1608-10 MetroPlaza No.555 LouShanGuan Road
ChangNing District Shanghai
People's Republic of China 200051
Phone : +86 (0)21-3250-5525
Fax : +86 (0)21-3250-5526
E-mail : ntc@ikonet.co.jp

Beijing Branch

Room 609 Scitech Tower
No.22 Jianguomenwai Avenue, Chaoyang District, Beijing
People's Republic of China 100004
Phone : +86 (0)10-6515-7681
Fax : +86 (0)10-6515-7681*106
E-mail : ntc@ikonet.co.jp

Guangzhou Branch

Room 834, Garden Tower, Garden Hotel
368 Huanshi East Road, Yuexiu District, Guangzhou, Guangdong
People's Republic of China 510064
Phone : +86 (0)20-8384-0797
Fax : +86 (0)20-8381-2863
E-mail : ntc@ikonet.co.jp

Wuhan Branch

Room 2300, Truroll Plaza No.72 Wusheng Road,
Qiao kou District, Wuhan, Hubei
People's Republic of China 430033
Phone : +86 (0)27-8556-1610
Fax : +86 (0)27-8556-1630
E-mail : ntc@ikonet.co.jp

Xi'an Office

Room 605, Zhongcai Finance Building,
No.22 Heping Road, Beilin District, Xi'an City, Shanxi Province,
People's Republic of China 710001
Phone : +86 (0)29-8882-3225
Fax : +86 (0)29-8882-3215
E-mail : ntc@ikonet.co.jp

Shenzhen Office

Room 532, Oriental Plaza,
1072 Jianshe Road, Luohu District, Shenzhen, Guangdong
People's Republic of China 518001
Phone : +86 (0)755-2265-0553
Fax : +86 (0)755-2298-0665
E-mail : ntc@ikonet.co.jp

Chengdu Office

Room 604 of Tower5, Weima Plaza,
No.2 Gaopan Rd, Wuhou District, Chengdu, Sichuan,
People's Republic of China 610041
Phone : +86 (0)28-6250-5159
Fax : +86 (0)28-6250-5159
E-mail : ntc@ikonet.co.jp

Ningbo Office

Room 3406, Zhongnongxin Building, No.181
Zhongshan East Road, Haishu Ward, Ningbo, Zhejiang
People's Republic of China 315000
Phone : +86 (0)574-8718-9535
Fax : +86 (0)574-8718-9533
E-mail : ntc@ikonet.co.jp

Qingdao Office

2107 Block A, World Trade Center Building, No.230
Changjiang Middle Road, Development Zone Qingdao
People's Republic of China 266555
Phone : +86 (0)532-8670-2246
FAX : +86 (0)532-8670-2242
E-mail : ntc@ikonet.co.jp

Shenyang Office

2-1203 Tower I, City Plaza Shenyang, No.206
Nanjing North Street Heping District, Shenyang
People's Republic of China 110001
Phone : +86 (0)24-2334-2662
FAX : +86 (0)24-2334-2442
E-mail : ntc@ikonet.co.jp

IKO THOMPSON ASIA CO., LTD. (THAILAND)

1-7 Zuellig House, 3rd Floor
Silom Road, Silom, Bangkok
Bangkok 10500, Thailand
Phone : +66 (0)2-637-5115
FAX : +66 (0)2-637-5116
E-mail : ita@ikonet.co.jp

IKO INTERNATIONAL, INC. (U.S.A.)

East Coast Operation (USA Headquarters)

91 Walsh Drive
Parsippany, NJ 07054
U.S.A.
Phone : +1 973-402-0254
Toll Free : 1-800-922-0337
Fax : +1 973-402-0441
E-mail : eco@ikonet.co.jp

Midwest Operations

500 East Thorndale Avenue, Suite K
Wood Dale, IL 60191
U.S.A.
Phone : +1 630-766-6464
Toll Free : 1-800-323-6694
Fax : +1 630-766-6869
E-mail : mwo@ikonet.co.jp

West Coast Operations

9830 Norwalk Boulevard, Suite 198
Santa Fe Springs, CA 90670
U.S.A.
Phone : +1 562-941-1019
Toll Free : 1-800-252-3665
Fax : +1 562-941-4027
E-mail : wco@ikonet.co.jp

Silicon Valley Sales Office

1500 Wyatt Drive, Suite 10
Santa Clara, CA 95054
U.S.A.
Phone : +1 408-492-0240
Toll Free : 1-800-252-3665
Fax : +1 408-492-0245
E-mail : wco@ikonet.co.jp

Southeast Operations

2150 Boggs Road, Suite 100
Duluth, GA 30096
U.S.A.
Phone : +1 770-418-1904
Toll Free : 1-800-874-6445
Fax : +1 770-418-9403
E-mail : seo@ikonet.co.jp

Southwest Operations

8105 N. Beltline Road, Suite 130
Irving, TX 75063
U.S.A.
Phone : +1 972-929-1515
Toll Free : 1-800-295-7886
Fax : +1 972-915-0060
E-mail : swo@ikonet.co.jp

See you again at

IKO Website

<http://www.ikont.co.jp/eg/>

NIPPON THOMPSON EUROPE B.V. (EUROPE)

The Netherlands (Europe Headquarters)

Sheffieldstraat 35-39
3047 AN Rotterdam
The Netherlands
Phone : +31 (0)10-462 68 68
Fax : +31 (0)10-462 60 99
E-mail : nte@ikonet.co.jp

Germany Branch

Mündelheimer Weg 56
40472 Düsseldorf
Germany
Phone : +49 (0)211-41 40 61
Fax : +49 (0)211-42 76 93
E-mail : ntd@ikonet.co.jp

Regensburg Sales Office

Im Gewerbepark D 30
93059 Regensburg
Germany
Phone : +49 (0)941-20 60 70
Fax : +49 (0)941-20 60 719
E-mail : ntdr@iko-nt.de

Neunkirchen Sales Office

Gruben Str.95c
66540 Neunkirchen
Germany
Phone : +49 (0)6821-99 98 60
Fax : +49 (0)6821-99 98 626
E-mail : ntdn@iko-nt.de

U.K. Branch

2 Vincent Avenue, Crownhill
Milton Keynes, Bucks, MK8 0AB
United Kingdom
Phone : +44 (0)1908-566144
Fax : +44 (0)1908-565458
E-mail : sales@iko.co.uk

Spain Branch

Autovia Madrid-Barcelona, Km. 43,700
Polig. Ind. AIDA - Nove A-8, Ofic. 2-1^a
19200 Azuqueca de Henares
(Guadalajara) Spain
Phone : +34 949-26 33 90
Fax : +34 949-26 31 13
E-mail : nts@ikonet.co.jp

France Branch

Roissypole Le Dôme
2 rue de La Haye
BP 15950 Tremblay en France
95733 Roissy C. D. G. Cedex
France
Phone : +33 (0)1-48 16 57 39
Fax : +33 (0)1-48 16 57 46
E-mail : contact@iko-france.com

Recognizing that conservation of the global environment is the top-priority challenge for the world's population, Nippon Thompson will conduct its activities with consideration of the environment as a corporate social responsibility, reduce its negative impact on the environment, and help foster a rich global environment.

**ISO 9001 & 14001 Quality system
registration certificate**



- The specifications and dimensions of products in this catalog are subject to change without prior notice.
- When these products are exported, the exporter should confirm a forwarding country and a use, and, in case of falling under the customer's requirements, take necessary procedures such as export permission application.
- Although all data in this catalog has been carefully compiled to make the information as complete as possible, NIPPON THOMPSON CO., LTD. shall not be liable for any damages whatsoever, direct or indirect, based upon any information in this catalog. NIPPON THOMPSON CO., LTD. makes no warranty, either express or implied, including the implied warranty of merchantability or fitness for a particular purpose.
- Reproduction and conversion without permission are prohibited.

IKO Linear Motion Rolling Guide Series General Catalog

RED

IKO Linear Motion Rolling Guide Series General Catalog RED



Eco-friendly and Excellent Quality

IKO Linear Motion Rolling Guides are used with satisfactory results for various applications requiring precision positioning such as semi-conductor manufacturing equipment, large sized machine tools, industrial robots, and precision equipment. In contrast to conventional rolling bearings used in rotating parts, Linear Motion Rolling Guides are the products applicable to plane sliding surfaces, and meet the increasing needs for linear motion and precision positioning in machines and equipment. Linear Way and Linear Roller Way of rail guide type, Linear Ball Spline of shaft guide type, and other products, recognized for their high quality and excellent features, are available.

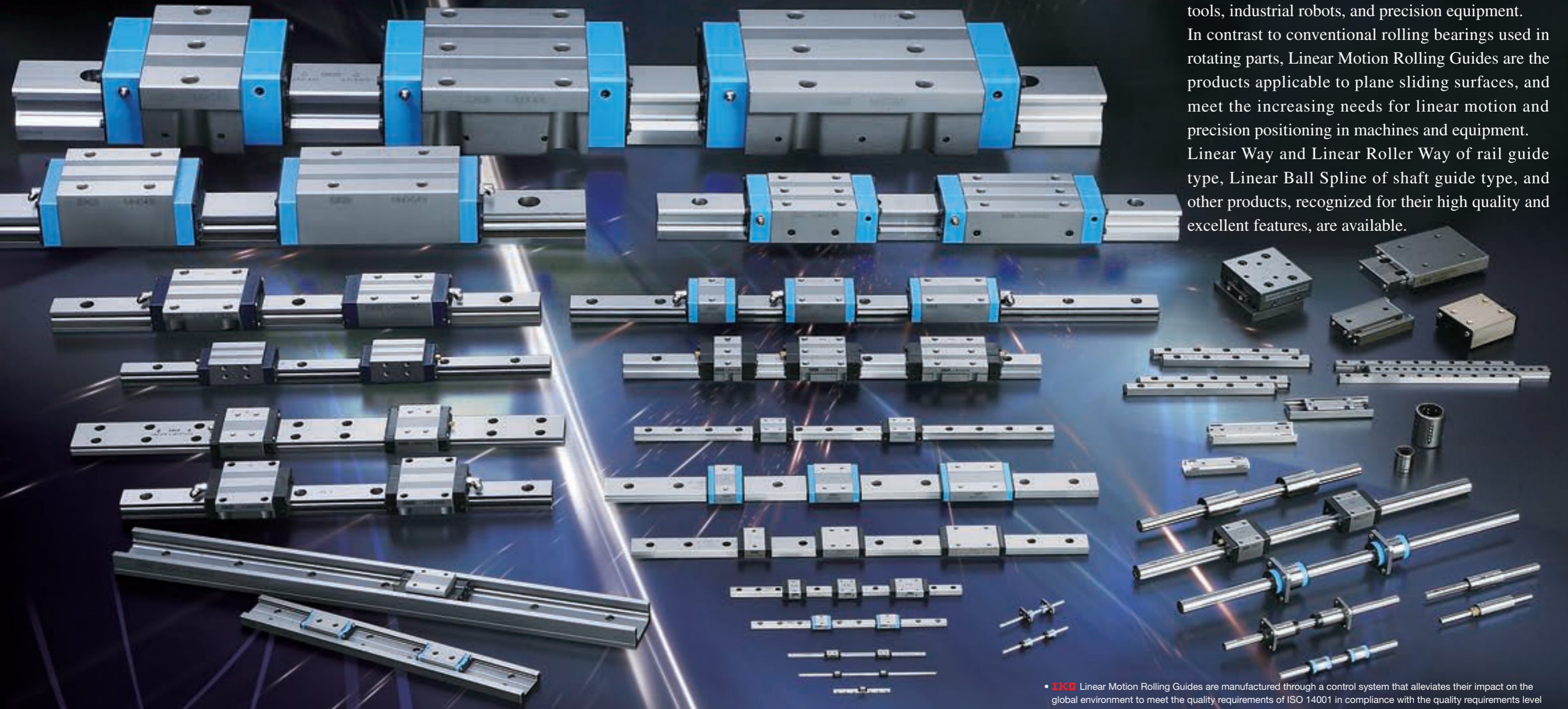

- **IKO** Linear Motion Rolling Guides are manufactured through a control system that alleviates their impact on the global environment to meet the quality requirements of ISO 14001 in compliance with the quality requirements level of ISO 9001 for quality improvement.
- The standard products listed in this catalog comply with the specifications of the six hazardous materials mentioned cited in the European RoHS Directive.



Recorded in CAT-1560E

Linear Way Linear Roller Way

Rail Guide Type



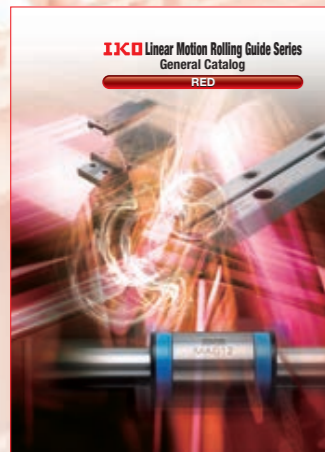



		C-Lube Maintenance Free Series	
	Ball Type Miniature Series Super small-size linear motion rolling guide produced by original small sizing technology	C-Lube Linear Way ML ML : Standard type MLF : Wide type	Linear Way L LWL : Standard type LWLF : Wide type
	Ball Type Miniature Value Series Economical linear motion rolling guides without changing the superior performance of Ball Type Miniature Series	C-Lube Linear Way MLV MLV	
	Ball Type Low Profile/Light Weight Series Super low profile and super light weight linear motion rolling guides with high load capacity	C-Lube Linear Way MV MV	
	Ball Type Compact Series Versatile linear motion rolling guides pursuing compactness in every aspect	C-Lube Linear Way ME ME : Flange type mounting from bottom MET : Flange type mounting from top MES : Block type mounting from top	Linear Way E LWE : Flange type mounting from bottom LWET : Flange type mounting from top LWES : Block type mounting from top
	Ball Type High Rigidity Series High rigidity linear motion rolling guides designed to evenly support high load capacity by incorporating large-diameter balls	C-Lube Linear Way MH MH : Flange type mounting from bottom MHT : Flange type mounting from top MHD : Block type mounting from top MHS : Compact block type mounting from top	Linear Way H LWH : Flange type mounting from bottom LWHT : Flange type mounting from top LWHD : Block type mounting from top LWHS : Compact block type mounting from top LWHY : Horizontal mounting type
	Ball Type Wide Rail Type Series Linear motion rolling guide suitable to single-row use due to having resistance to across-the-width moment load by using a wide track rail		Linear Way F LWFH : Flange type mounting from top / bottom LWFF : Flange type mounting from top / bottom LWFS : Block type mounting from top
	Ball Type U-Shaped Track Rail Series Linear motion rolling guide of high track rail rigidity with U-shaped track rail	C-Lube Linear Way MUL MUL : Small type	Linear Way U LWUL...B : Small type LWU...B : Standard ball-retained type LWU : Standard ball non-retained type
	Roller Type Linear motion rolling guide that has achieved the highest level of performance in all characteristics utilizing the roller's superior characteristic	C-Lube Linear Roller Way Super MX MX : Flange type mounting from top / bottom MXD : Block type mounting from top MXS : Compact block type mounting from top MXN : Low profile flange type mounting from top / bottom MXNS : Low profile block type mounting from top	Linear Roller Way Super X LRX : Flange type mounting from top / bottom LRXD : Block type mounting from top LRXS : Compact block type mounting from top
	Roller Type Roller type linear motion rolling guide with cylindrical rollers in four-rows		Linear Roller Way X LRWX : Block type mounting from top LRWXH : Flange type mounting from bottom
	Module Type Minimum compact linear motion rolling guide with both a track rail and slide member provided		Linear Way Module LWLM : Ball type small type LWM : Ball type standard type LRWM : Roller type



Recorded in CAT-1561E

Crossed Roller Way Linear Slide Unit Linear Ball Spline Linear Bushing Stroke Rotary Bushing Roller Way & Flat Roller Cage

Shaft Guide Type







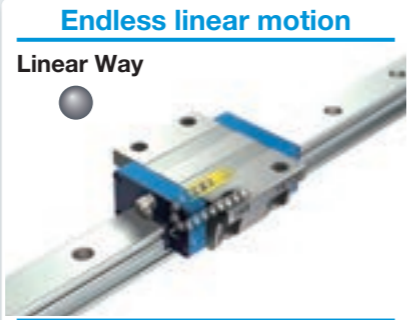

	Crossed Roller Way Linear motion rolling guide incorporating a roller cage between two ways whose two V-shaped surfaces are used as track groove		Anti-Creep Cage Crossed Roller Way CRWG Anti-Creep Cage Crossed Roller Way Unit CRWUG	Anti-Creep Cage Crossed Roller Way H CRWG...H Crossed Roller Way Unit CRWU / CRWU...R / CRWU...RS	Crossed Roller Way CRW : Standard type CRWM : Module type
	Linear Slide Unit Light weight, small, and compact linear motion rolling guide that has achieved light and smooth motion		High Rigidity Precision Linear Slide Unit BWU	Precision Linear Slide Unit BSP : Limited linear motion type BSPG : Built-in rack & pinion type BSR : Endless linear motion type	Linear Slide Unit BSU...A
	Linear Ball Spline Linear motion rolling guide performing linear motion while performing torque transmission along the spline shaft by external cylinder or slide unit	C-Lube Linear Ball Spline MAG MAG : Standard type MAGF : Flange type	Linear Ball Spline G LSAG : Standard type LSAGF : Flange type	Block Type Linear Ball Spline LSB	Stroke Ball Spline LS
	Linear Bushing A wide variety of linear motion rolling guides facilitating the rolling motion in bush guide portion		Linear Bushing G LMG	Linear Bushing LM / LME / LMB	Miniature Linear Bushing LMS
	Stroke Rotary Bushing Linear motion rolling guide enabling the rolling motion and rotary and linear motion in axial direction		Stroke Rotary Bushing ST : Ordinary type ST...B : For heavy load	Miniature Stroke Rotary Bushing STSI : Assembled set with a shaft STS : Assembled set without a shaft	Stroke Rotary Cage BG
	Roller Way & Flat Roller Cage High accuracy linear motion rolling guide providing high rigidity in load direction		Roller Way RW / SR / GSN	Flat Roller Cage FT : Single row type FTW...A : Double row angle type	

IKO Types and Specifications of

Linear Motion Rolling Guide Series

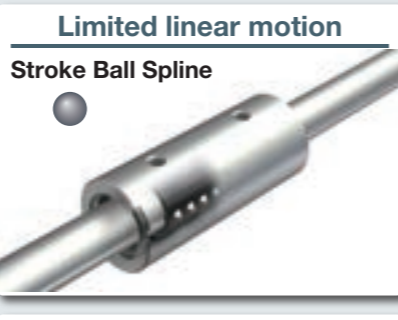
Types of Linear Motion Rolling Guides

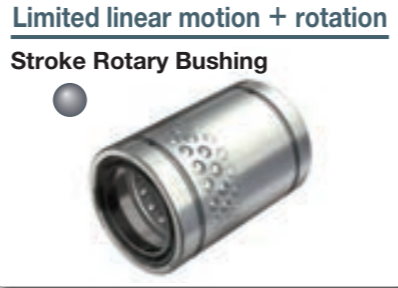
Specifications of Linear Motion Rolling Guides

Guide Type	Description	Endless linear motion	Limited linear motion
Rail Guide Type	The rail guide type achieves linear motion along a rail. This product can receive a complex load and features high performance, excellent total balance and easy handling.	Linear Way 	Crossed Roller Way 
		Linear Roller Way 	Linear Slide Unit 
Shaft Guide Type	The shaft guide type achieves linear motion along a shaft. This product is easy to handle and suitable for relatively low load conditions. Some shaft guide products can achieve both rotation and reciprocating linear motion.	Linear Ball Spline 	Stroke Ball Spline 
		Linear Bushing 	Limited linear motion + rotation Stroke Rotary Bushing 
Flat Guide Type	The flat guide type achieves linear motion on a surface. This product can receive only a unidirectional load but feature high rigidity in the load direction.	Roller Way 	Flat Roller Cage 

		Type of rolling element	Type of motion	Load direction and load carrying capacity	Rigidity	Frictional characteristic	Ease of mounting	General applications	Item-listed catalog
Rail Guide Type	Endless linear motion	Linear Way	Endless linear motion	Complex load, medium to heavy load	○	○	○	• NC machine tool • Precision working machine • Robot • Transfer machine	BLUE
		Linear Roller Way	Endless linear motion	Complex load, heavy to extra-heavy load	◎	○	◎	• Heavy duty machine tool • Large working machine • High-rigidity robot	BLUE
	Limited linear motion	Crossed Roller Way	Limited linear motion	Complex load, medium load	○	◎	◎	• Precision working machine • Electronic parts assembling machine • Precision measuring instrument	RED
		Linear Slide Unit	Limited linear motion	Complex load, light to medium load	△	◎	◎	• Electronic parts assembling machine	RED
Shaft Guide Type	Endless linear motion	Linear Ball Spline	Endless linear motion	Complex load, medium to heavy load	○	○	○	• Robot • Testing and inspection equipment • Transfer machine	RED
		Linear Bushing	Endless linear motion	Radial load, light load	△	○	○	• Packaging machine • Measuring instrument • Medical instrument	RED
	Limited linear motion	Stroke Ball Spline	Limited linear motion	Complex load, medium to heavy load	○	◎	○	• Robot • Testing and inspection equipment	RED
		Stroke Rotary Bushing	Limited linear motion + rotation	Radial load, light load	△	◎	○	• Printing press • Press die set • Precision measuring instrument	RED
Flat Guide Type	Endless linear motion	Roller Way	Endless linear motion	Unidirectional load, extra-heavy load	◎	○	△	• NC machine tool • Precision working machine	RED
	Limited linear motion	Flat Roller Cage	Limited linear motion	Unidirectional load, extra-heavy load	◎	◎	○	• Precision working machine • Optical measuring instrument	RED

Code description ◎Excellent ○Good △Fair



Crossed Roller Way

Linear motion rolling guide incorporating a roller cage between two ways whose two V-shaped surfaces are used as track groove



Anti-Creep Cage Crossed Roller Way

Anti-Creep Cage Crossed Roller Way H



Crossed Roller Way

Anti-Creep Cage Crossed Roller Way Unit

Crossed Roller Way Unit



Linear Slide Unit

Light weight, small, and compact linear motion rolling guide that has achieved light and smooth motion



High Rigidity Precision Linear Slide Unit



Precision Linear Slide Unit



Linear Slide Unit



Linear Ball Spline

Linear motion rolling guide performing linear motion while performing torque transmission along the spline shaft by external cylinder or slide unit



C-Lube Linear Ball Spline MAG



Linear Ball Spline G



Block Type Linear Ball Spline



Stroke Ball Spline



Linear Bushing

A wide variety of linear motion rolling guides facilitating the rolling motion in bush guide portion



Linear Bushing G



Linear Bushing



Miniature Linear Bushing



Stroke Rotary Bushing

Linear motion rolling guide enabling the rolling motion and rotary and linear motion in axial direction



Stroke Rotary Bushing



Miniature Stroke Rotary Bushing



Stroke Rotary Cage



Roller Way & Flat Roller Cage

High accuracy linear motion rolling guide providing high rigidity in load direction



Roller Way



Flat Roller Cage

CRW(G)(...H)
CRW(G)

BWU · BSP(G)
BSU...A

MAG · LSAG
LSB · LS

LMG · LM · LMS

ST · STSI · BG

RW · SR · GSN
FT · FTW...A



U.S. PATENTED	
Crossed Roller Way	Linear Ball Spline
No. 8360644	No. 6190046 5967667
8142079	6176617 5490729
6971797	6082899
6736541	
Linear Slide Unit	Linear Bushing
No. 7344310	No. 6099410
7008107	5893646
5553946	
C-Lube Linear Ball Spline MAG	
No. 7637662	



Explanation and Dimension Table for Respective Product Series

Rail Guide Type

Crossed Roller Way

- Anti-Creep Cage
Crossed Roller Way
Anti-Creep Cage
Crossed Roller Way H
Crossed Roller Way
Explanation ... II -7 Dimension Table ... II -27
- Anti-Creep Cage
Crossed Roller Way Unit
Crossed Roller Way Unit
Explanation ... II -55 Dimension Table ... II -61

Linear Slide Unit

- High Rigidity Precision Linear Slide Unit
Explanation ... II -75 Dimension Table ... II -81
- Precision Linear Slide Unit
Explanation ... II -83 Dimension Table ... II -89
- Linear Slide Unit
Explanation ... II -95 Dimension Table ... II -99

Round Shaft Guide Type

Linear Ball Spline

- C-Lube Linear Ball Spline MAG
Linear Ball Spline G
Explanation ... II -107 Dimension Table ... II -123
- Block Type Linear Ball Spline
Explanation ... II -131 Dimension Table ... II -141
- Stroke Ball Spline
Explanation ... II -143 Dimension Table ... II -149

General Explanation

- General Explanation III -2

Introduction of Application Examples

- Introduction of Application Examples IV -2

Linear Bushing

- Linear Bushing G
Explanation ... II -153 Dimension Table ... II -159
- Linear Bushing
Explanation ... II -161 Dimension Table ... II -167
- Miniature Linear Bushing
Explanation ... II -189 Dimension Table ... II -192

Stroke Rotary Bushing

- Stroke Rotary Bushing
Explanation ... II -195 Dimension Table ... II -199
- Miniature Stroke Rotary Bushing
Explanation ... II -203 Dimension Table ... II -207
- Stroke Rotary Cage
Explanation ... II -209 Dimension Table ... II -212

Flat Guide Type

- Roller Way
Explanation ... II -215 Dimension Table ... II -221
- Flat Roller Cage
Explanation ... II -225 Dimension Table ... II -231

Crossed Roller Way

Anti-Creep Cage Crossed Roller Way

Anti-Creep Cage Crossed Roller Way H

Crossed Roller Way

Anti-Creep Cage Crossed Roller Way Unit

Crossed Roller Way Unit

CRW(G)(...H)
CRWU(G)

A wide variety of series products including mechanism are available! **Features of**

IKO Crossed Roller Way is a linear motion rolling guide incorporating a roller cage between two ways whose two V-shaped surfaces are used as track groove. Arrangement of cylindrical rollers by orthogonalizing them alternately allows receiving of loads in any direction and executes extremely high-accuracy and smooth linear motion.

Crossed Roller Way **CRW·CRWM**



Crossed Roller Way Unit **CRWU**



Anti-Creep Cage Crossed Roller Way **CRWG**

IKO Anti-Creep Cage Crossed Roller Way CRWG is a product with a cage creep proof function using a rack and pinion mechanism originated from the Crossed Roller Way CRW featuring smooth linear motion with super high accuracy. CRWG ... H is high load capacity type of CRWG, which has achieved greatly increased load rating by redesigning of raceway of CRWG.

Anti-Creep Cage Crossed Roller Way H **CRWG...H**

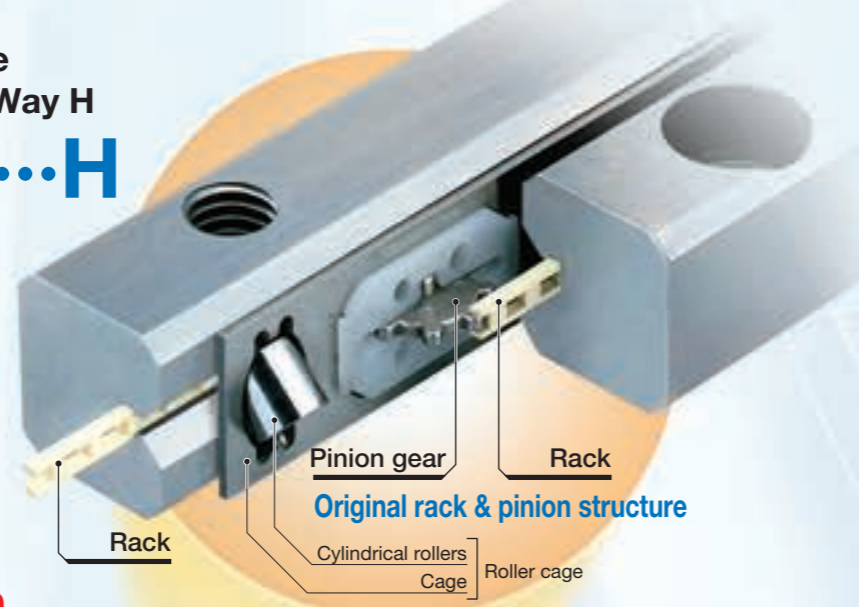

**Built-in rack & pinion type
Solves cage creep issue!!**

Anti-Creep Cage Crossed Roller Way Unit **CRWUG**

IKO Anti-Creep Cage Crossed Roller Way Unit CRWUG is a product with a cage creep proof function-provided Crossed Roller Way CRWG mounted into a ground-finished rigid table and bed.

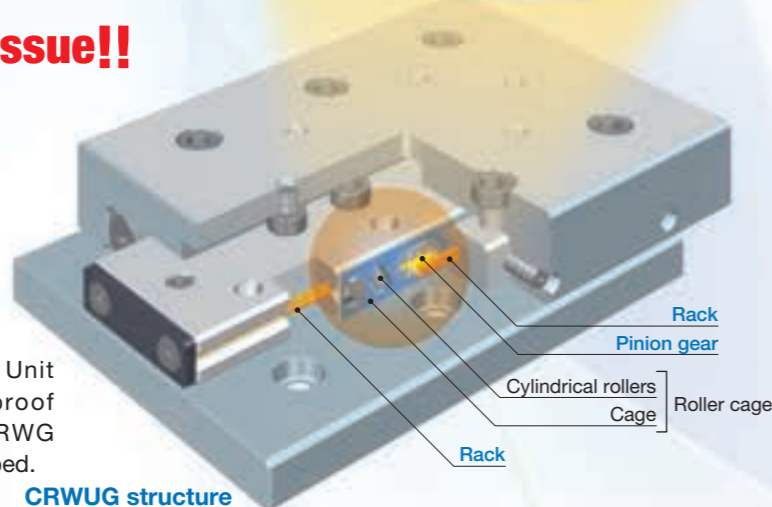

CRWUG structure

cage misalignment prevention **Crossed Roller Way**

Features of Built-in Rack & Pinion Type

Solves Cage Creep Issue!

Perfect solution for cage creep issues by a built-in rack and pinion mechanism as an original design.

Freedom in Mounting

This series is reliable for applications such as vertical axis where Crossed Roller Way may have chances of cage creep.

High-Speed and High-Tact Operation

Any corrective operation for cage creep is not necessary even for high velocity operation.

Saving Energy

No remedy motion of cage is necessary even in long term operation.

No cage creep even under high-tact operation in vertical axis!

(Durability test) Test conditions

Model number	CRWG3	
Test method	Vibration test machine	
Condition	Posture	Vertical
	Maximum velocity	827 mm/s
	Acceleration	15 G
	Number of cycle	31 Hz
	Stroke length	8 mm
Total cycles	100,000,000 cycles	

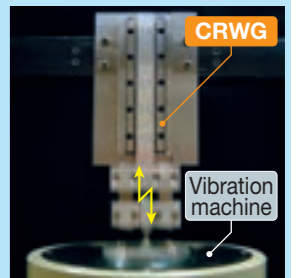

(Result) No cage creep nor material damage in any component is found.

Interchangeable in Mounting Dimensions!

Adoption of original structure of arranging a rack inside the way keeps the same mounting dimensions as conventional Crossed Roller Way CRW.

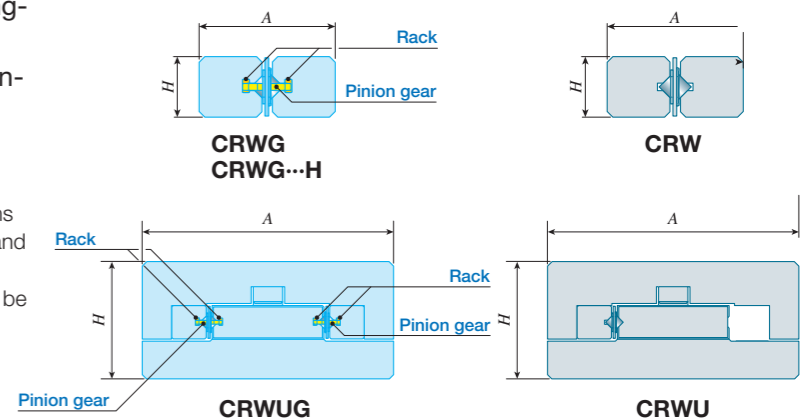

Easy Replacement

Since they have the same external dimensions to those of the existing Crossed Roller Way and Crossed Roller Way Unit, existing Crossed Roller Way and Crossed Roller Way Unit can be replaced without any mounting dimensions modification.

Smooth and Extremely-High Accurate Operation!

Combination of precisely finished raceways and non-recirculating type linear motion rolling guide with super high precision rollers provides superbly smooth motion with very high accuracy.

Improved Running Accuracy

Extremely high running accuracy can be achieved without run deflection by recirculating type linear motion rolling guide.

Suitable for Micro-Feeding

Improvement of precision positioning accuracy and superior corresponding feature to micro-feeding command can be expected because of the linear motion without stick-slip by extremely small frictional resistance.

Anti-Creep Cage
Crossed Roller Way

CRWG

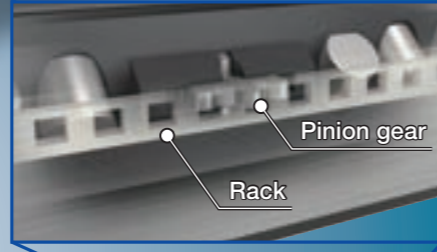

Anti-Creep Cage
Crossed Roller Way H

CRWG...H

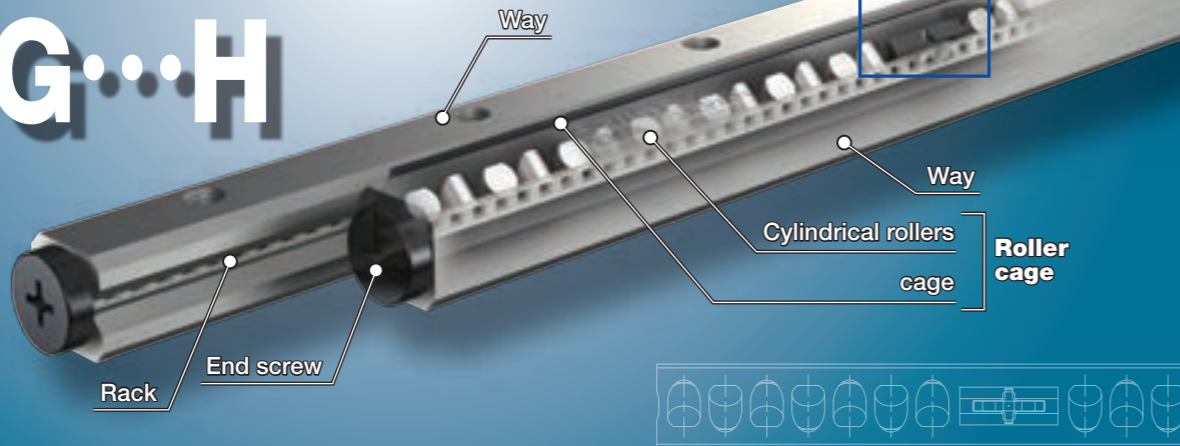

Crossed Roller Way
CRW/CRWM

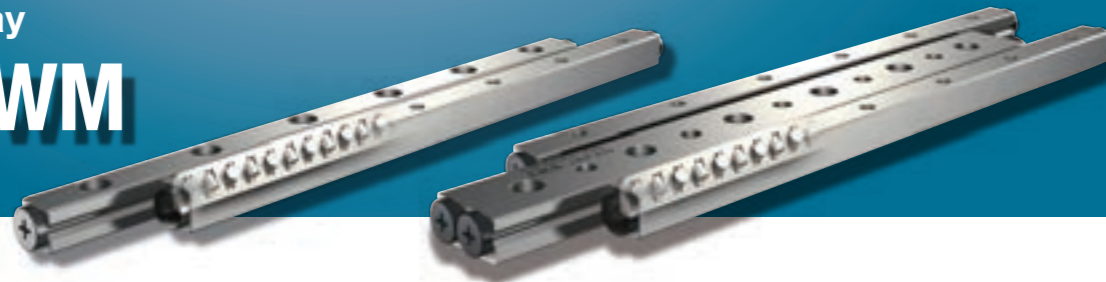

Points

● Superior load balance

1 This unit has a roller cage with cylindrical rollers alternately orthogonalized between two ways whose two V-shaped surfaces are used as track groove, which allows receiving of loads in any direction.

● Solves cage creep problem

2 CRWG and CRWG...H units, which have originally-designed rack and pinion mechanism built-in, solve the cage creep issue and support high-speed & high-tact operation and vertical axis application.

● High load capacity type CRWG...H

3 CRWG...H has achieved greatly increased load rating by redesigning of raceway of CRWG, thereby downsizing the machine and equipment and prolonging their lifetime.

● Standard type and module type

4 There are two types in the CRW: one is standard type of using four ways and two roller cages in combination as a set and the other is module type of integrating two internal ways in a single structure.

● Easy mounting

5 The mounting holes of the way are provided with boring and female thread, so that the mounting structure is not restricted. The module type with two internal ways integrated in a single structure is simple in mounting structure, thus producing high accuracy linear motion.

● Stainless steels superior in corrosion resistance are listed on lineup.

6 Products made of stainless steel are highly resistance to corrosion, so that they are suitable for applications where rust prevention oil is not preferred, such as in a cleanroom environment.

Identification Number and Specification

Example of an identification number

The specifications of CRWG series, CRWG...H series, and CRW series are indicated by the identification number. Indicate the identification number, consisting of a model code, a dimension, a part code, a material code, a classification symbol, and any supplemental codes for each specification to apply.

	1	2	3	1	4	5	6	7
CRWG series	CRWG	3	- 150	H			SP	/B
CRWG...H series								
CRW series	CRW	3	- 150		C20	SL	SP	/U
Standard type								
	CRW	3	- 250×300		C36	SL	SP	/U
Module type								
	CRWM	3	- 150		C20		SP	/U
	CRWM	3	- 250×150		C20		SP	/U

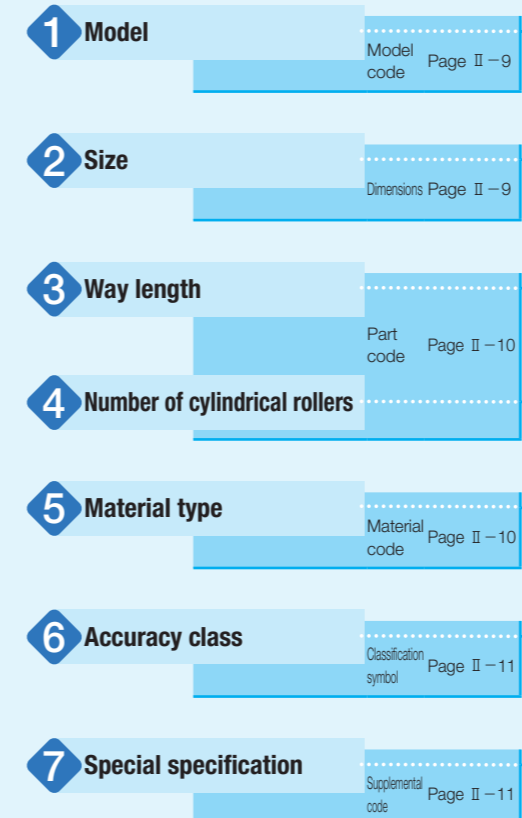

Note: One set of the CRW, CRWG, and CRWG...H series consists of a combination of four ways and two roller cages.

CRW(G)...H
CRW(G)

Identification Number and Specification — Model · Size —

1 Model	Anti-Creep Cage Crossed Roller Way (CRWG series)	: CRWG
	Anti-Creep Cage Crossed Roller Way H (CRWG...H series)	: CRWG...H
	Crossed Roller Way (CRW series)	Standard type : CRW Module type : CRWM
	For applicable models and sizes, see Fig. 1.	

2 Size	1, 2, 3, 4, 6, 9, 12, 15, 18, 24	For applicable models and sizes, see Fig. 1.
---------------	----------------------------------	--

Table 1 Models and Sizes of CRWG series, CRWG...H series, and CRW series

Series	Shape	Material	Model	Size										
				1	2	3	4	6	9	12	15	18	24	
CRWG		High carbon steel made	CRWG	—	○	○	○	○	—	—	—	—	—	—
CRWG...H		High carbon steel made	CRWG...H	○	○	○	○	—	—	—	—	—	—	—
CRW	Standard type 	High carbon steel made	CRW	○	○	○	○	○	○	○	○	○	○	○
		Stainless steel made	CRW...SL	○	○	○	○	○	—	—	—	—	—	—
	Module type 	High carbon steel made	CRWM	○	○	○	○	—	—	—	—	—	—	—

— Way length · Number of Cylindrical Rollers · Material Type —

3 Way length	○	The way length is indicated in mm. The CRW series can be combined with a way of different length. For details of way length, see the dimension tables on pages II-27 to II-54.
	○×○	

Specifying the combination of different way lengths

Combination of standard type

This combination consists of two short ways, two long ways, and two roller cages, as a set.

In this case, make sure to specify the number of rollers to be incorporated in the roller cages. (For calculation of incorporated rollers, see the Selection of CRW Series on page II-17.)

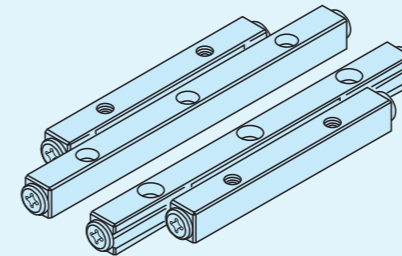
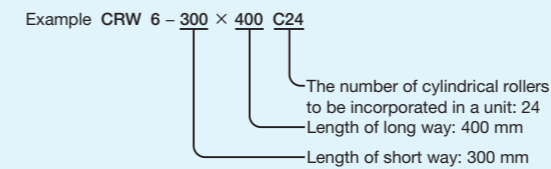

Combination of module type

This combination consists of one long center way, two short ways, and two roller cages, as a set.

In this case, make sure to specify the number of rollers to be incorporated in the roller cages. (For calculation of incorporated rollers, see the Selection of CRW Series on page II-17.)

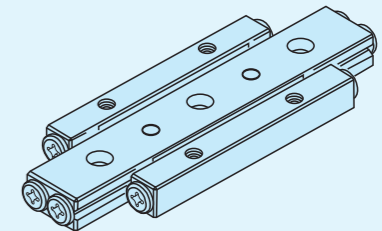
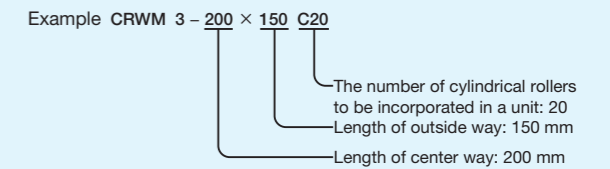

4 Number of cylindrical rollers	: No symbol	This represents the number of cylindrical rollers incorporated into a CRW series cage. If not directed, the number of cylindrical rollers indicated in the dimension table shall be incorporated in a roller cage.
	: C○	

5 Material type	High carbon steel made	: No symbol	For applicable models and sizes, see Fig. 1.
	Stainless steel made	: SL	

6 Accuracy class	Standard	: No symbol	For parallelism of the raceway to reference mounting surface and the tolerance of the parallelism of two raceways of CRWM, see Fig. 1.
	Super precision	: SP	

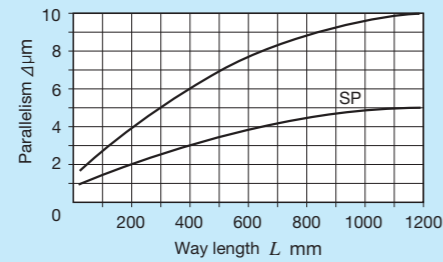
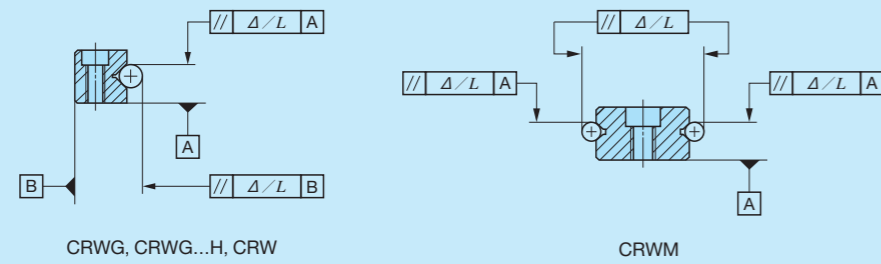

Fig. 1 Accuracy

7 Special specification	B, M, SA, SB, U	For applicable special specifications, see Table 2.
		For combination of multiple special specifications, see Table 3. For details of special specifications, see pages II-12 to II-14.

Table 2 Application of special specifications

Special specification	Supplemental code	Size									
		1	2	3	4	6	9	12	15	18	24
Special mounting screw	/B	—	—	○	○	○	○	○	○	○	○
High rigidity roller cage ⁽¹⁾ ⁽²⁾	/M	—	—	—	—	○	○	○	○	○	○
End stopper SA ⁽²⁾	/SA	—	○	○	○	○	○	○	○	○	○
End stopper SB ⁽²⁾	/SB	—	○	○	○	○	○	○	○	○	○
Wiper seal ⁽²⁾	/U	—	○	○	○	○	○	○	○	○	○

Notes ⁽¹⁾ Not applicable to module type.
⁽²⁾ Not applicable to CRWG series and CRWG...H series.

Table 3 Combination of special specifications

M	○			
SA	○	○		
SB	○	○	—	
U	○	○	—	—
	B	M	SA	SB

Remarks 1. The combination of "-" shown in the table is not available.
2. When using multiple types for combination, please indicate by arranging the symbols in alphabetical order.

Special mounting screw /B

Preload adjusting-side way can be moved by adjusting the preload. Allowance for movement is required between a way fixing screw and mounting hole, but special mounting screws are provided for the cases where enough allowance is not provided or a fixing screw should be mounted from the way side as shown in Fig. 2. This special mounting screw can also be used for the case where the mounting hole for mounting the fixed-side way and positioning accuracy of female thread are not enough. This special mounting screw is high carbon steel-made only.

Table 4 Dimensions of special mounting screw

Size	Bolt size	d	D	H	L	S
3	M 3	2.3	5	3	12	5
4	M 4	3.1	6	4	15	6
6	M 5	3.9	8	5	20	8
9	M 6	4.6	8.5	6	30	12
12	M 8	6.2	11.5	8	40	17
15	M10	7.9	14	10	45	16
18	M12	9.6	16	12	50	19
24	M14	11.2	19.5	14	70	26

unit: mm

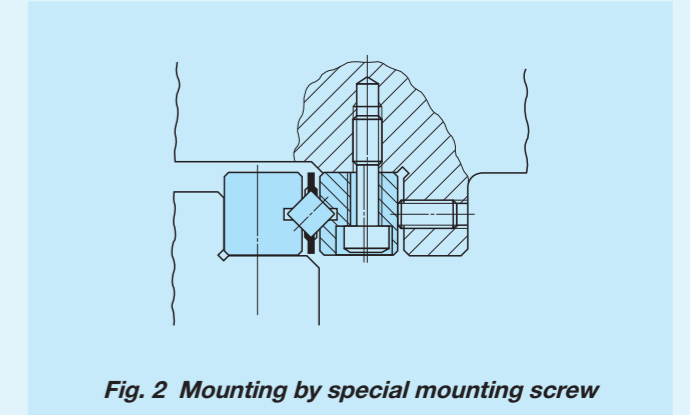
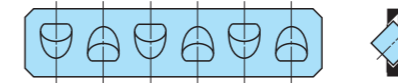

Fig. 2 Mounting by special mounting screw

High rigidity roller cage /M



The cage is changed into a high rigidity copper alloy-made cage designed to suit vertical axis application. This cage has a structure to prevent a roller from dropping off in one-side direction. For using a high rigidity roller cage for vertical axis application, it is recommended to use the cage in combination with end stopper SB.

End stopper SA /SA

When the stroke frequency is high and cage creep may be caused by the vibration and non-uniformly varying load, the end screw is changed into end stopper SA.
For the series of size 1, an end stopper SA according to end stopper SA is included as standard.

Table 5 Dimensions of end stopper SA

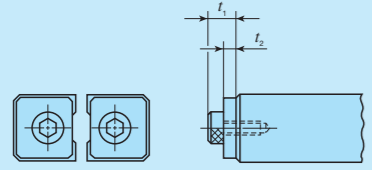

unit: mm

Size	t_1	t_2
2	4.5	2
3	5	2
4	7	3
6	8	3
9	10	4

Size	t_1	t_2
12	11	5
15	14	6
18	14	6
24	16	6

End stopper SB /SB

When using a high rigidity roller cage for vertical axis application, the end screw is changed into end stopper SB to regulate the cage stroke at the end.
The end stopper SB cannot be mounted on all way ends. Standard mounting positions are shown in Fig. 3. The mounting positions can be changed by loosening the screw.

Table 6 Dimensions of end stopper SB

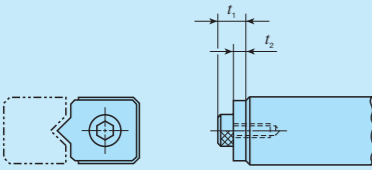

unit: mm

Size	t_1	t_2
2	4.5	2
3	5	2
4	7	3
6	8	3
9	10	4

Size	t_1	t_2
12	11	5
15	14	6
18	14	6
24	16	6

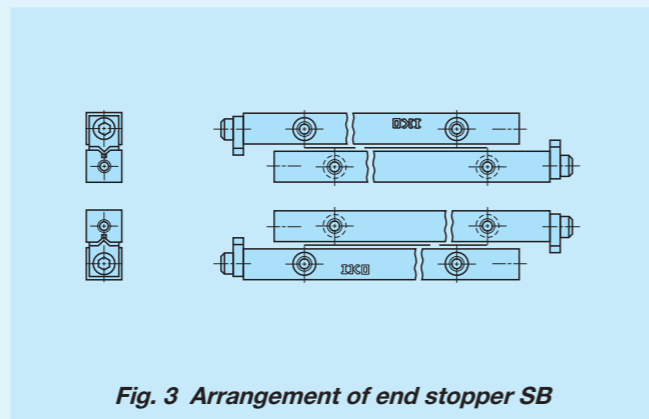
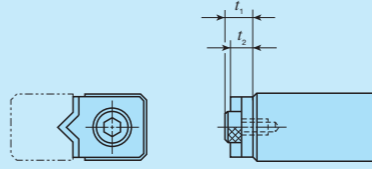

Fig. 3 Arrangement of end stopper SB

Wiper seal /U

In order to prevent foreign substances from entering into a raceway, the wiper seal is changed into the one with a function of end stopper SB.
The wiper seal cannot be mounted on all way ends. Standard mounting positions are shown in Fig. 4. The mounting positions can be changed by loosening the screw.

Table 7 Dimensions of wiper seal



unit: mm

Size	t_1	t_2
2	4.5	4
3	5	4
4	7	6
6	8	6
9	10	7.5

Size	t_1	t_2
12	11	8.5
15	14	11
18	14	11
24	16	11

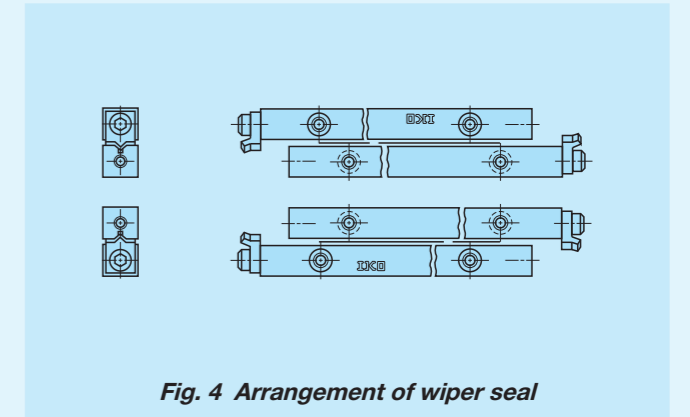

Fig. 4 Arrangement of wiper seal

Load Rating and Allowable Load

Basic dynamic load rating C , basic static load rating C_0 , and allowable load F of the CRWG series and CRWG...H series show values for downward loads in case of parallel arrangement of four ways and two pairs of roller cages as one set. (Refer to Fig. 5) In addition, the upward and lateral load rating is the same as downward load rating.

For the CRW series, since the number of cylindrical rollers that share load of each direction varies, the load rating for each load direction and allowable load must be obtained. In addition, basic dynamic load rating C_U , basic static load rating C_{0U} , and allowable load F_U in the dimension table show values per cylindrical roller.

Basic dynamic load rating C , basic static load rating C_0 , and allowable load F of the CRW series are obtained based on the equation indicated in Table 8.1 and Table 8.2.

For more information on the definition of load rating and calculated load, see page III-3.

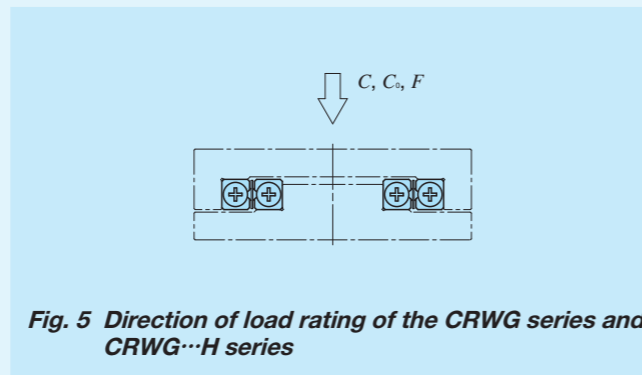

Allowable load

Allowable load refers to load of smooth rolling motion on contact surface to which maximum contact stress is applied and the sum of whose elastic deformation of rolling elements and raceway is small.

Therefore, use applied load within the allowable load range if very smooth rolling motion and high accuracy are required.

Table 8.1 Calculating formula of load rating and allowable load of standard type CRW series

Load direction	Upward and downward load ⁽¹⁾	Lateral load
Basic dynamic load rating C	$C_r = \left\{ \left(\frac{Z}{2} - 1 \right) 2p \right\}^{1/36} \left(\frac{Z}{2} \right)^{3/4} C_U \dots \dots \dots (1)$	$C_a = \left\{ \left(\frac{Z}{2} - 1 \right) 2p \right\}^{1/36} \left(\frac{Z}{2} \right)^{3/4} 2^{7/9} C_U \dots \dots \dots (4)$
Basic static load rating C_0	$C_{0r} = 2 \left(\frac{Z}{2} \right) C_{0U} \dots \dots \dots (2)$	$C_{0a} = 2 \left(\frac{Z}{2} \right) C_{0U} \dots \dots \dots (5)$
Allowable load F	$F_r = 2 \left(\frac{Z}{2} \right) F_U \dots \dots \dots (3)$	$F_a = 2 \left(\frac{Z}{2} \right) F_U \dots \dots \dots (6)$
Code description	C_r : Basic dynamic load rating in case upward and downward load is applied N	
	C_a : Basic dynamic load rating in case lateral load is applied N	
	C_{0r} : Basic static load rating in case upward and downward load is applied N	
	C_{0a} : Basic static load rating in case lateral load is applied N	
	F_r : Allowable load in case upward and downward load is applied N	
	F_a : Allowable load in case lateral load is applied N	
	Z : The number of cylindrical rollers incorporated in a roller cage (omit the figures after the decimal fractions for $\frac{Z}{2}$)	
	p : Inter-pitch dimensions of cylindrical rollers mm	
C_U : Basic dynamic load rating per cylindrical roller N		
C_{0U} : Basic static load rating per cylindrical roller N		
F_U : Allowable load per cylindrical roller N		

Note ⁽¹⁾ : In case of parallel arrangement in this load direction, calculation must be performed based on the equations (7) , (8) , and (9) in Table 8.2.

Table 8.2 Calculating formula of load rating and allowable load of module type CRW series

Load direction	Upward and downward load	Lateral load
Basic dynamic load rating C	$C_r = \left\{ \left(\frac{Z}{2} - 1 \right) 2p \right\}^{1/36} \left(\frac{Z}{2} \right)^{3/4} 2^{7/9} C_U \dots \dots \dots (7)$	$C_a = \left\{ \left(\frac{Z}{2} - 1 \right) 2p \right\}^{1/36} \left(\frac{Z}{2} \right)^{3/4} 2^{7/9} C_U \dots \dots \dots (10)$
Basic static load rating C_0	$C_{0r} = 2 \left(\frac{Z}{2} \right) C_{0U} \dots \dots \dots (8)$	$C_{0a} = 2 \left(\frac{Z}{2} \right) C_{0U} \dots \dots \dots (11)$
Allowable load F	$F_r = 2 \left(\frac{Z}{2} \right) F_U \dots \dots \dots (9)$	$F_a = 2 \left(\frac{Z}{2} \right) F_U \dots \dots \dots (12)$
Code description	C_r : Basic dynamic load rating in case upward and downward load is applied N	
	C_a : Basic dynamic load rating in case lateral load is applied N	
	C_{0r} : Basic static load rating in case upward and downward load is applied N	
	C_{0a} : Basic static load rating in case lateral load is applied N	
	F_r : Allowable load in case upward and downward load is applied N	
	F_a : Allowable load in case lateral load is applied N	
	Z : The number of cylindrical rollers incorporated in a roller cage (omit the figures after the decimal fractions for $\frac{Z}{2}$)	
	p : Inter-pitch dimensions of cylindrical rollers mm	
C_U : Basic dynamic load rating per cylindrical roller N		
C_{0U} : Basic static load rating per cylindrical roller N		
F_U : Allowable load per cylindrical roller N		

CRW(G)(...H)
CRW(G)

Selection of CRW Series

For selection of CRW series specifications, stroke length and the number of cylindrical rollers, as well as accuracy, load rating and allowable load, must be determined.

Stroke length and the number of cylindrical rollers

Stroke length of the CRW series affects the way length and the number of cylindrical rollers. Therefore, select specifications by following the procedure below taking into account the stroke length used and applied load.

1 Calculation of way length

The way length, which should be 1.5 times longer than the stroke length used, is obtained from the equation below.

$$L \geq 1.5S \quad (13)$$

Where L : Way length mm
 S : Stroke length used mm

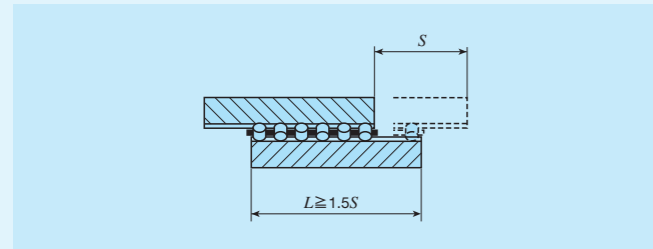

2 Calculation of maximum stroke length

Ideally the stroke length used should be less than 80% of the maximum stroke length, which is obtained from the equation below.

$$S_1 \geq \frac{1}{0.8} S \quad (14)$$

Where S_1 : Maximum stroke length mm
 S : Stroke length used mm

3 Calculation of cage length and the number of rollers

With the way length and maximum stroke length determined, the allowable length for cage can be calculated. Calculation method of the cage length varies depending on specifications of end screws and end stopper fitted to the way end.

(1) With standard end screws and end stopper SA (excluding Size 1 series)
 The dimensions between rollers at both ends is obtained from the following equation by using a value obtained by subtracting a half of the maximum stroke length from the way length.

$$L_R = L - \frac{S_1}{2} \quad (15)$$

Where L_R : Allowable dimensions between rollers at both ends mm
 L : Way length mm
 S_1 : Maximum stroke length mm

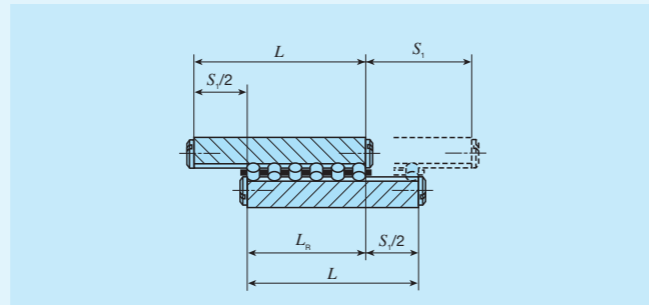

The number of rollers to be incorporated in a roller cage is obtained by the following equation.

$$Z = \frac{L_R - D_w}{p} + 1 \quad (16)$$

Where Z : Number of cylindrical rollers (figures after the decimal fractions are omitted)
 L_R : Allowed dimensions between rollers at both ends mm
 D_w : Diameter of cylindrical rollers (refer to the dimension table) mm
 p : Inter-pitch dimensions of cylindrical rollers (refer to the dimension table) mm

(2) For Size 1 series

The stroke length is regulated by cage and end stopper and the cage length is obtained by the following equation.

$$R = L - \frac{S_1}{2} \quad (17)$$

Where R : Allowable cage length mm
 L : Way length mm
 S_1 : Maximum stroke length mm

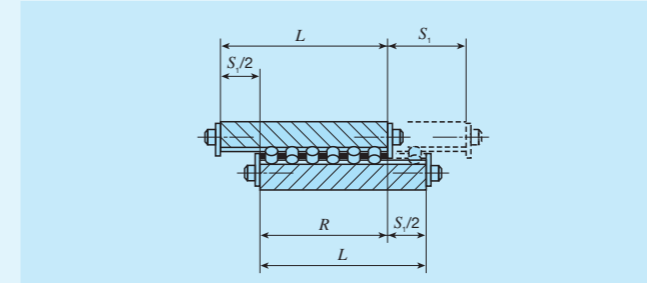

The number of rollers to be incorporated in a roller cage is obtained by the following equation.

$$Z = \frac{R - 2e}{p} + 1 \quad (18)$$

Where Z : Number of cylindrical rollers (figures after the decimal fractions are omitted)
 R : Allowable cage length mm
 e : End dimension of cage (refer to the dimension table) mm
 p : Inter-pitch dimensions of cylindrical rollers (refer to the dimension table) mm

(3) For end stopper SB and wiper seal

The stroke length is regulated by cage and end stopper or wiper seal and the cage length is obtained by the following equation.

$$R = L - t_2 - S_1 \quad (19)$$

Where R : Allowable cage length mm
 L : Way length mm
 S_1 : Maximum stroke length mm
 t_2 : Thickness of end stopper SB or wiper seal mm (See Table 6 in page II-13, and Table 7 in page II-14)

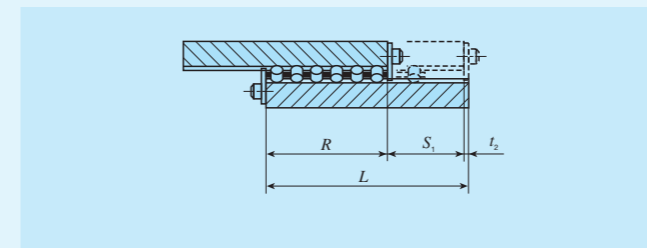

The number of rollers to be incorporated in a roller cage is obtained by the equation (18) as with the Size 1 series.

Calculation examples

Form of use CRW 6
 Applied load $P = 7000$ N
 Stroke length $S = 195$ mm

Select specifications for parallel use of Crossed Roller Way under the above conditions (refer to Fig. 26 in page II-23).

1 Calculation of way length

The way length L is calculated from the equation (13).

$$L \geq 1.5S = 1.5 \times 195 = 292.5$$

Therefore, select $L = 300$ mm based on the standard length in the dimension table.

2 Calculation of maximum stroke length

The maximum stroke length S_1 is calculated from the equation (14).

$$S_1 \geq \frac{1}{0.8} S = \frac{1}{0.8} \times 195 \approx 244$$

Allowable dimensions between rollers at both ends L_R is calculated from the equation (15).

$$L_R = L - \frac{S_1}{2} = 300 - \frac{244}{2} = 178$$

3 Calculation of the number of rollers

The number of cylindrical rollers Z is calculated from the equation (16). However, D_w and p in this form are $D_w = 6$ mm, $p = 9$ mm according to the dimension table.

$$Z = \frac{L_R - D_w}{p} + 1 = \frac{178 - 6}{9} + 1 \approx 20.1$$

Therefore, it should be $Z = 20$ by omitting figures after the decimal fractions.

4 Calculation of allowable load

Allowable load in parallel arrangement F is calculated from equation (9) described in Table 8.2 in page II-16. However, allowable load per cylindrical roller F_U is $F_U = 769$ N according to the dimension table.

$$F = 2 \left(\frac{Z}{2} \right) F_U = 2 \left(\frac{20}{2} \right) \times 769 = 15380$$

Therefore, allowable load F is larger than applied load $P = 7000$ N. When allowable load becomes smaller than applied load, it is necessary to increase the number of cylindrical rollers by extending way length, or increase the cylindrical roller diameter.

5 Determination of specifications

Specifications obtained in accordance with the above is CRW6-300 and the number of cylindrical rollers is 20.

Lubrication

Grease is not pre-packed in the CRWG series, CRWG...H series and CRW series, so please perform adequate lubrication as needed.

Both of oil lubrication and grease lubrication are available in the CRWG series, CRWG...H series and CRW series. Generally, oil lubrication should be selected for high speed or low frictional resistance, and grease lubrication for low speed. For grease lubrication, use of high-quality lithium-soap base grease is recommended. For light load and low speed, apply grease or oil to raceway, rack and pinion gear first and then reapply accordingly. However, the structure as indicated in the Fig. 6 allows for easy reapplication. In addition, since the clearance between ways is small for CRWG...H series, apply grease or oil directly to raceway for re-greasing.

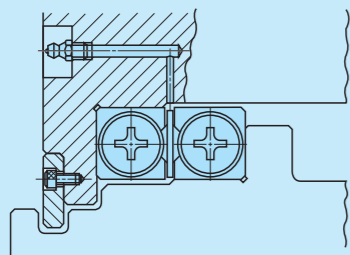

Fig. 6 Example of lubrication system

Dust Protection

Since the CRWG series, CRWG...H series and CRW series are finished with high accuracy, harmful foreign substances such as dust and particles entering into the bearing will cause low life or impaired accuracy. To prevent harmful foreign substances such as dust, particles and water from outside from entering, it is recommended to attach non-contact type labyrinth seal as indicated in Fig. 7, or contact type wiper seal as indicated in the Fig. 8 to both sides.

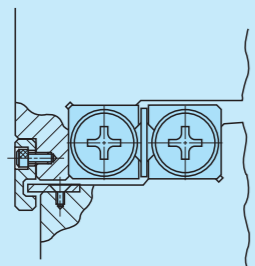

Fig. 7 Example of labyrinth seal

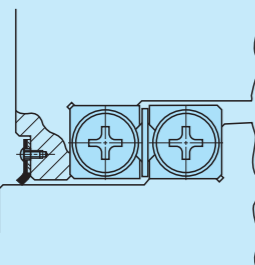

Fig. 8 Example of wiper seal

Precaution for Use

① Handling

As the CRWG series, CRWG...H series and CRW series are designed highly precisely, take extra care for handling.

A pinion gear and cylindrical roller are incorporated with the cage for the CRWG series and CRWG...H series. When the cage is dropped or handled roughly, the pinion gear and cylindrical roller may come off. Especially for CRWG...H, grabbing the cylindrical roller may take it off, so be sure to hold the cage body for handling. In addition, do not cut off the cage as doing so may cause pinion gear coming off and breakage of gear joint section.

A rack is incorporated with the way for the CRWG series and CRWG...H series. In operation, take note that the rack may come off when the end screw is removed.

Though the cage for the CRW series may cut off to necessary length, handle it with care not to deform it when cutting.

② Accuracy of mounting part

Examples of typical mounting surface processing are shown in Fig. 9.1 and Fig. 9.2.

General processing accuracy of mounting surface is according to Table 9. However, care should be exercised as mounting surface accuracy directly affects running accuracy. Especially when high running accuracy is required, the processing accuracy higher than that indicated in Table 9 is required.

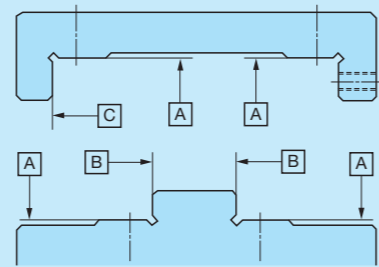

Fig. 9.1 Example of processing of CRWG, CRWG...H and CRW mounting surface

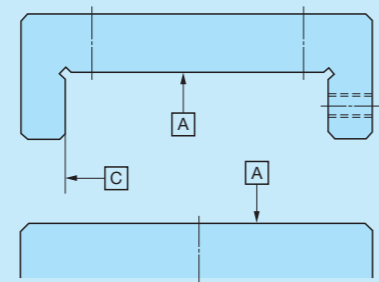

Fig. 9.2 Example of processing of CRWM mounting surface

Table 9 Accuracy of mounting part

Accuracy of A surface	<ul style="list-style-type: none"> Directly affects running accuracy. For the flatness of two mounting surfaces on table and bed sides, allowable value approximate to the parallelism indicated in Fig. 1 in page II-11 is recommended.
Accuracy of B and C surfaces	<ul style="list-style-type: none"> Flatness: Affects preload (refer to ④ Preload adjustment mechanism). II-11 Allowable value approximate to the parallelism indicated in Fig. 1 in page II-11 is recommended. Squareness: Affects rigidity in preload direction of the mounting part of the CRWG series, CRWG...H series and CRW series. Process to sufficiently high accuracy.

③ Shape of mounting part

For the opposite corner of the mating reference mounting, it is recommended to have relieved fillet as indicated in Fig. 10.

In addition, a clearance of 0.5 mm or higher should be made between the way and the mating member material.

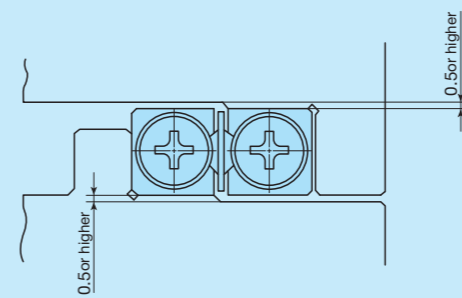

Fig. 10 Shape of mounting part

④ Preload adjustment mechanism

For use with preload, use the preload adjusting screw as indicated in Fig. 11 as a general way. Preload adjusting screw nominal dimensions and mounting position should be in accordance with the way fixing bolt dimensions and position. Press the center of the way H dimensions.

Preload amount varies depending on operational conditions of your machine and device. However, as excessive preload may lead to short life and damage on the raceway, it is typically ideal to adjust to zero clearance or slight preload state. When accuracy and rigidity are required, use a push plate or tapered jib as indicated in Fig. 12 and Fig. 13, respectively.

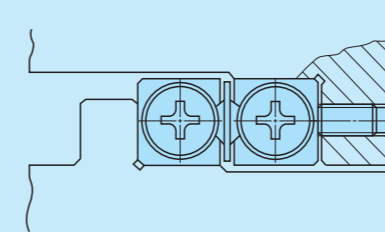

Fig. 11 Example of typical preload adjustment

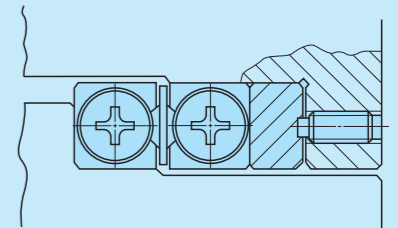

Fig. 12 Example of push plate

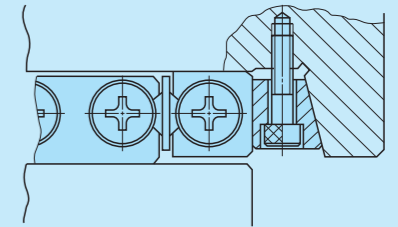

Fig. 13 Example of tapered jib

⑤ Operating temperature

As synthetic resin components are used for the CRWG series and CRWG...H series, the maximum operating temperature is 120°C, while it should be lower than 100°C for continuous use. When it exceeds 100°C, contact **IKO**. As synthetic resin components are not used for the CRW series, it may be used at high temperature. However, when it exceeds 100°C, contact **IKO**.

⑥ Maximum velocity

Operating velocity should be lower than 50 m/min for the CRWG series and CRWG...H series, and lower than 30 m/min for the CRW series.

⑦ Tightening torque for fixing screw

Typical tightening torque for mounting of the CRWG series, CRWG...H series and CRW series is indicated in Table 10. When vibration and shock are large or moment load is applied, it is recommended to fix by using the torque 1.3 times larger than that indicated in the table. In addition, when high running accuracy is required with no vibration and shock, it may be fixed by using torque smaller than that indicated in the table, however, it is recommended to use adhesive agent to fasten the screw, or to use stop bolts.

Table 10 Tightening torque for fixing screw

Bolt size	Tightening torque N · m
M 1.6 × 0.35	0.20
M 2 × 0.4	0.40
M 3 × 0.5	1.4
M 4 × 0.7	3.2
M 5 × 0.8	6.4
M 6 × 1	10.9
M 8 × 1.25	26.1
M10 × 1.5	51.1
M12 × 1.75	88.2
M14 × 2	140
M16 × 2	215

Remark:
When fixing screws used on the table side and bed side are not identical, fasten them all to the smaller tightening torque.

1N=0.102kgf=0.2248lbs.
1mm=0.03937inch

Mounting

Mounting of CRWG series and CRWG...H series

Typical mounting structure is shown in Fig. 14. For mounting at this point, generally follow the procedure below.

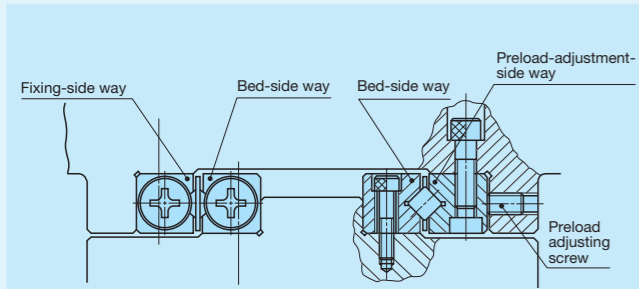

Fig. 14 Mounting example of CRWG and CRWG...H

1 Preparation for mounting

- Products are packed by set (4 ways and 2 pairs of roller cages). Be careful not to mix with other sets.
- Remove end screws and end stopper, clean up each part with clean wash fluid and then apply rust prevention and lubrication oil.

2 Cleanup of mounting surface

- Remove burrs and blemishes on the machine mounting surface with an oil-stone, etc. Be careful about corner groove on the mounting surface, too.
- Wipe off dust and dirt with clean cloth and apply rust prevention and lubrication oil lightly.

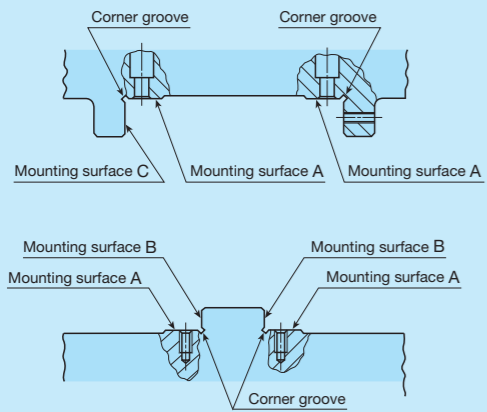

Fig. 15 Mounting surface

3 Mounting of bed-side way

- Properly align the way with mounting surface and temporarily tighten fixing screws evenly to the tightening torque.
- While making the way sticking to B surface (refer to Fig. 15) tight, fully tighten the screws to the specified torque.
- When high running accuracy is required, fully and evenly tighten them to the specified torque while checking the parallelism of the raceway along the full length of the way.
- Typical tightening torque for fixing screw is according to Table 10 in page II-20.

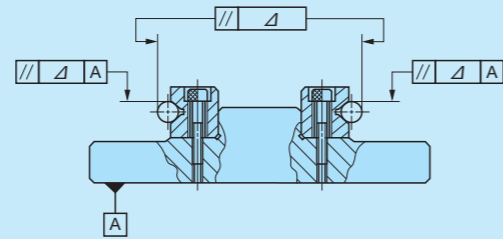

Fig. 16 Accuracy of way mounting

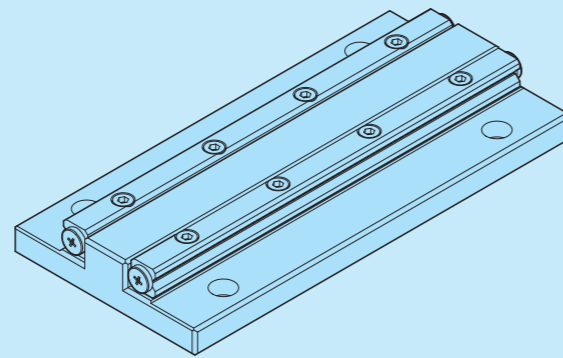

Fig. 17

4 Operation of table and bed

- Position the roller cages at the stroke end positions of the bed-side way. (Refer to Fig. 18)
- Mate the pinion gear at the center of the cage and the rack of the way.
- At this point, be careful not to deform the cage.

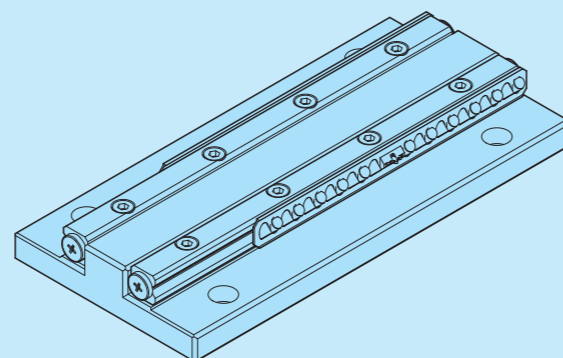

Fig. 18

- Position the table-side way in the stroke end position. (Refer to Fig. 19)
- Mate the pinion gear at the center of the cage and the rack of the table-side way.

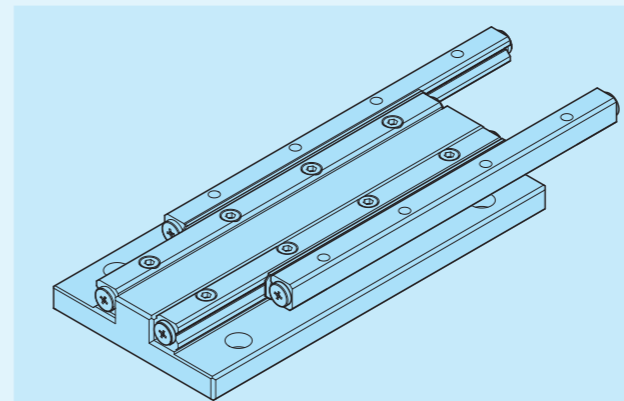

Fig. 19

- Position the table-side way approximately in the stroke center position. (Refer to Fig. 20)

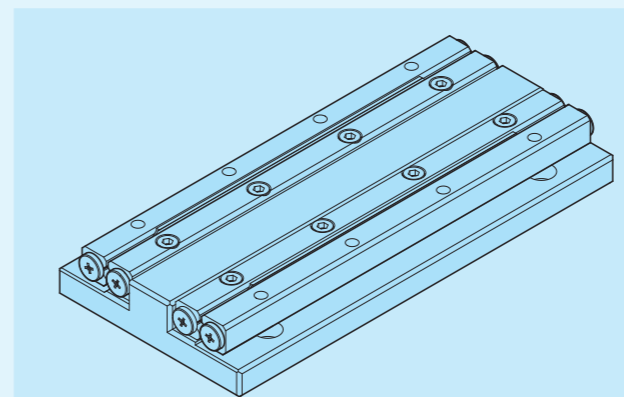

Fig. 20

- Position the table while holding the way to prevent it from moving. (Refer to Fig. 21)

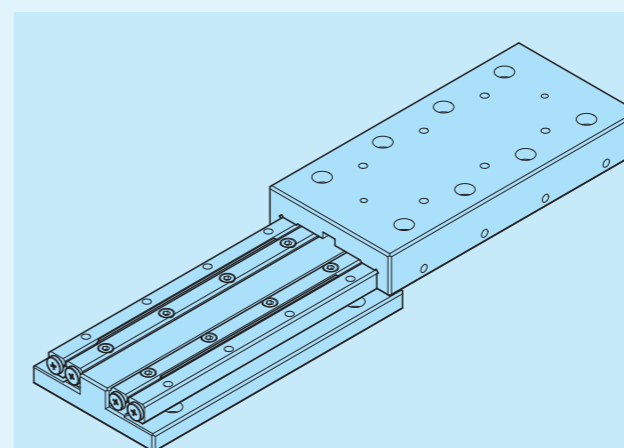

Fig. 21

- Temporarily tighten the table fixing screws. (Refer to Fig. 22)

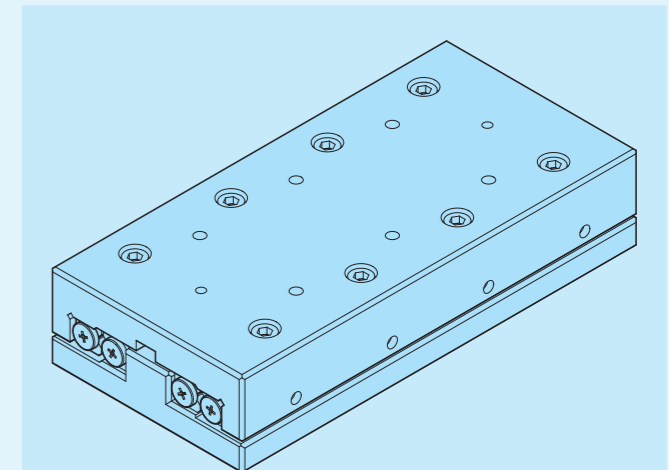

Fig. 22

- Fully stroke the table softly and check that it is within the stroke range used and cylindrical rollers on both ends of the cage do not contact with end screws of the way. If they make contact, take the procedure again. (Refer to Fig. 23)

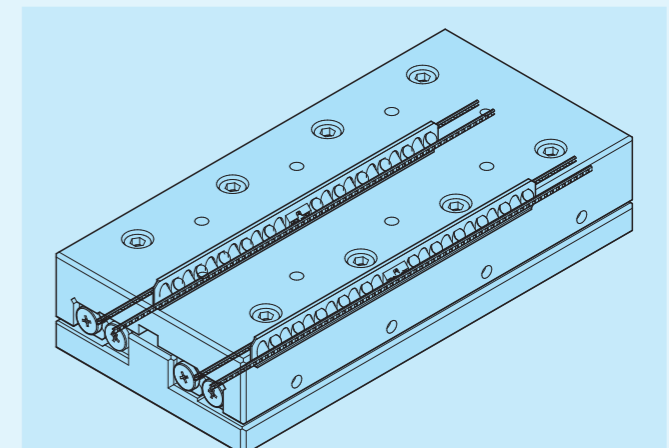

Fig. 23

5 Preload adjustment

- Preload adjustment is performed with fixing screws of the table-side way tightened temporarily.
- Preload adjustment is started from the preload adjusting screw at the center of way length and then both ends in turn.
- While measuring the clearance on the table sides, tighten the preload adjusting screws subsequently until deflection of the dial gauge stops. Measure the tightening torque for preload adjusting screws at this point.
- When adjusting preload adjusting screw near either end, stroke the table softly and check that the cylindrical roller is on the preload adjusting screw section.
- After the above procedure, the clearance becomes zero or in slight preload state, but preload is still not adjusted evenly. With the same procedure again, re-adjust all the preload adjusting screws evenly to the torque previously measured.

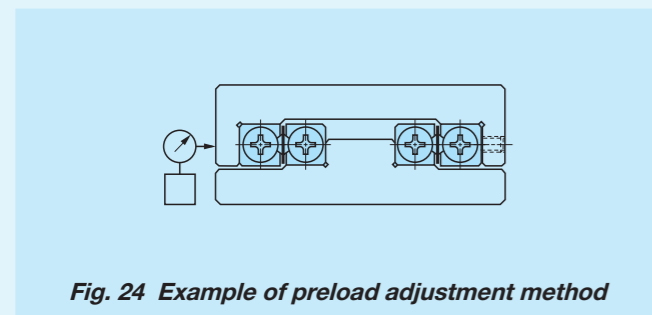

Fig. 24 Example of preload adjustment method

6 Full tightening of preload-adjustment-side way

- Fixing screws are lightly tightened to even torque. As with preload adjusting screws, temporarily fix them to torque similar to the specified torque in turn from the way center to both ends.
- When tightening fixing screws near either end, stroke the table softly and check that the cylindrical roller is on fixing screw section.
- Finally with the same procedure, fully tighten all the fixing screws evenly to the specified torque.

7 Check after assembly

- Fully stroke the table softly and check that running is smooth without abnormal noise.
- Measure the table upper and side surfaces with dial gauge or the like and check the running accuracy.

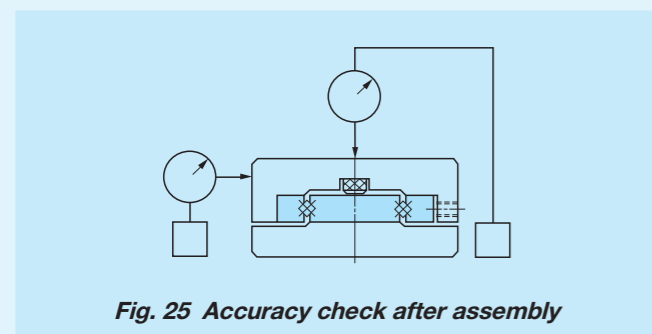

Fig. 25 Accuracy check after assembly

Mounting of standard type CRW series

Typical mounting structure is shown in Fig. 26. For mounting at this point, generally follow the procedure below.

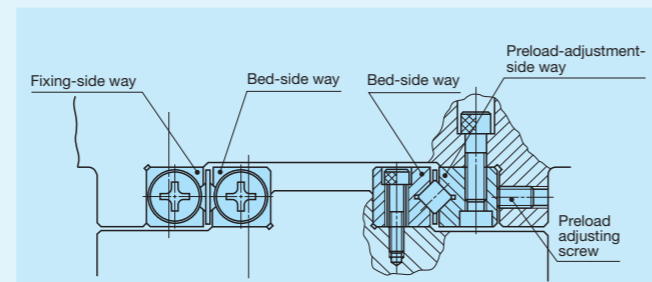

Fig. 26 Mounting example of standard type CRW series

1 Preparation for mounting

- Products are packed by set (4 ways and 2 pairs of roller cages). Be careful not to mix with other sets.
- Remove end screws and end stopper, clean up each part with clean wash fluid and then apply rust prevention and lubrication oil.

2 Cleanup of mounting surface

- Remove burrs and blemishes on the machine mounting surface with an oil-stone, etc. Be careful about corner groove on the mounting surface, too.
- Wipe off dust and dirt with clean cloth and apply rust prevention and lubrication oil lightly.

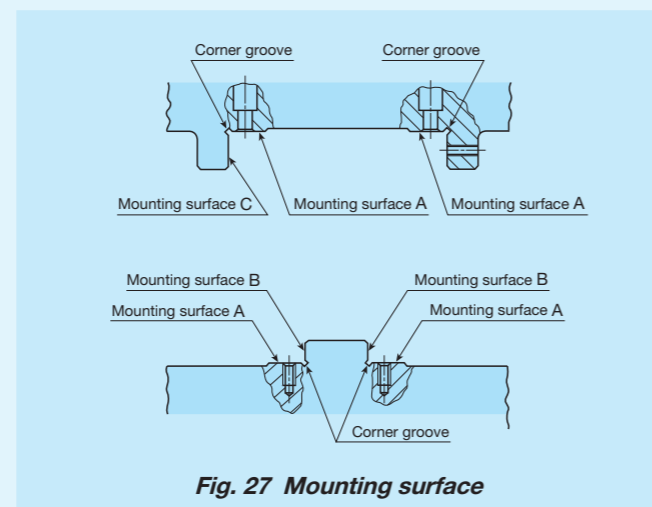

Fig. 27 Mounting surface

3 Mounting of bed-side way

- Properly align the way with mounting surface and temporarily tighten fixing screws evenly to the tightening torque.
- While making the way sticking to B surface (refer to Fig. 27) tight, fully tighten the screws to the specified torque.
- When high running accuracy is required, fully and evenly tighten them to the specified torque while checking the parallelism of the raceway along the full length of the way.
- Typical tightening torque for fixing screw is according to Table 10 in page II-20.

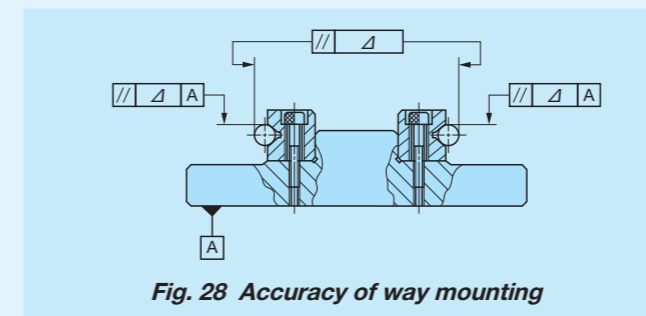

Fig. 28 Accuracy of way mounting

4 Mounting of table-side way

- Properly align the fixing-side way with mounting surface and temporarily tighten fixing screws evenly to the tightening torque.
- While making the fixing-side way sticking to C surface tight, fully tighten the screws to the specified torque.
- Set back the preload adjusting screws in advance, make the preload-adjusting-side way sticking to the mounting surface, and then temporarily tighten fixing screws lightly to the even torque.

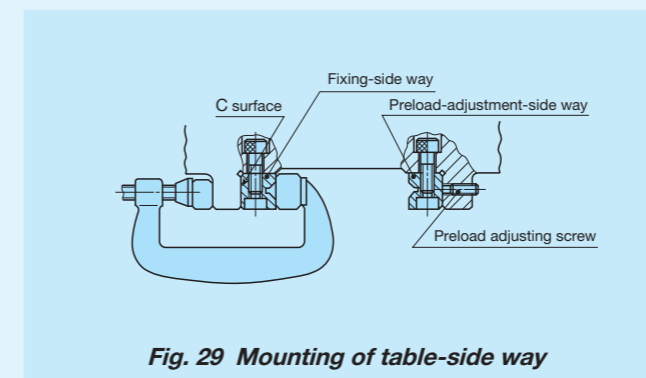

Fig. 29 Mounting of table-side way

5 Operation of table and bed

- Make alignment of the position in height and cross direction so that the roller cage can be inserted between the table-side way and bed-side way.
- Carefully insert the roller cage and assembly it at approximate center of the way length. At this point, be careful not to deform the cage.
- Mount end screws and end stopper of each way.
- Push the entire table against the preload adjusting screws and tighten the preload adjusting screws to make temporary adjustment until the clearance between ways becomes zero.
- Fully stroke the table softly and correct the roller cage position to the center.

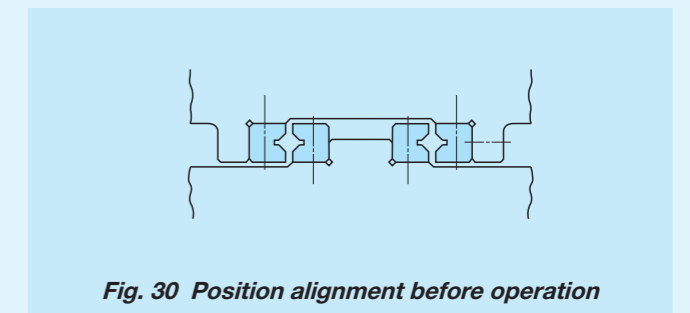

Fig. 30 Position alignment before operation

6 Preload adjustment

- Preload adjustment is performed with fixing screws of the preload-adjusting-side way tightened temporarily.
- Preload adjustment is started from the preload adjusting screw at the center of way length and then both ends in turn.
- While measuring the clearance on the table sides, tighten the preload adjusting screws subsequently until deflection of the dial gauge stops. Measure the tightening torque for preload adjusting screws at this point.
- When adjusting preload adjusting screw near either end, stroke the table softly and check that the cylindrical roller is on the preload adjusting screw section.
- After the above procedure, the clearance becomes zero or in slight preload state, but preload is still not adjusted evenly. With the same procedure again, re-adjust all the preload adjusting screws evenly to the torque previously measured.

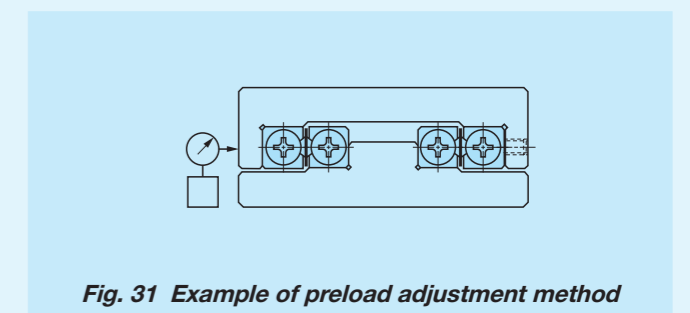

Fig. 31 Example of preload adjustment method

7 Full tightening of preload-adjustment-side way

- Fixing screws are lightly tightened to even torque. As with preload adjusting screws, temporarily fix them to torque similar to the specified torque in turn from the way center to both ends.
- When tightening fixing screws near either end, stroke the table softly and check that the cylindrical roller is on fixing screw section.
- Finally with the same procedure, fully tighten all the fixing screws evenly to the specified torque.

8 Check after assembly

- Fully stroke the table softly and check that running is smooth without abnormal noise.
- Measure the table upper and side surfaces with dial gauge or the like and check the running accuracy.

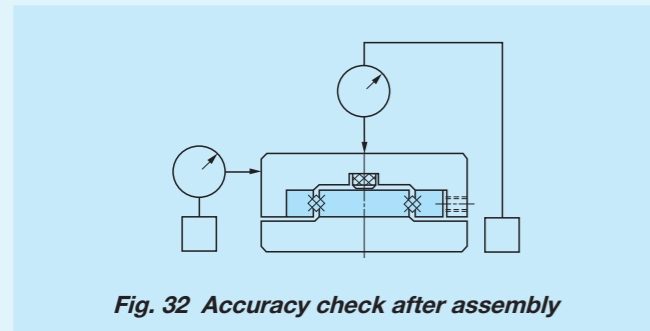

Fig. 32 Accuracy check after assembly

Mounting of module type CRW series

Typical mounting structure of CRWM is shown in Fig. 33. For mounting at this point, generally follow the procedure below.

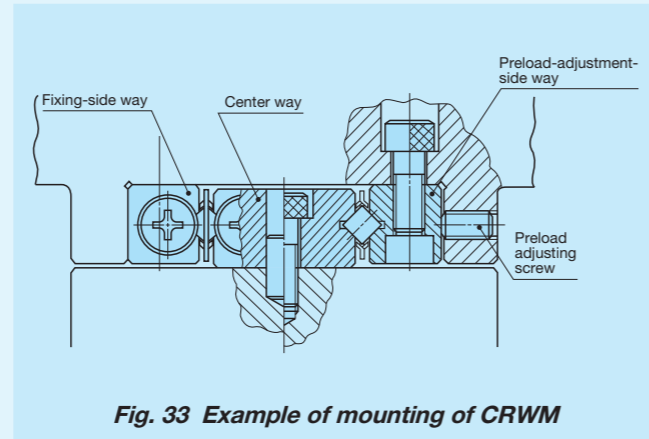

Fig. 33 Example of mounting of CRWM

1 Preparation for mounting

- Crossed Roller Way is packed by set (1 center way, 2 ways and 2 pairs of roller cages). Be careful not to mix with other sets.
- Remove end screws and end stopper, clean up each part with clean wash fluid and then apply rust prevention and lubrication oil.

2 Cleanup of mounting surface

- Remove burrs and blemishes on the machine mounting surface with an oil-stone, etc. Be careful about corner groove on the mounting surface, too.
- Wipe off dust and dirt with clean cloth and apply rust prevention and lubrication oil lightly.

3 Mounting of center way

- Roughly align the center way to the mounting surface and lightly fix it with fixing screws.
- While measuring mounting parallelism of the center way and raceway to the reference surface of running parallelism for position correction, temporarily tighten the fixing screws to the even tightening torque.
- Evenly tighten all the fixing screws to the specified tightening torque.

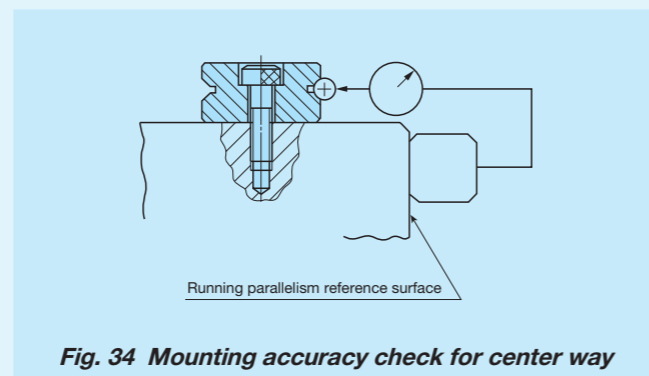

Fig. 34 Mounting accuracy check for center way

4 Processing of dowel pin hole

- When dowel pins are used, machine holes on the bed in alignment with dowel pin holes near either end of the center way.
- Dowel pin hole of the center way is finished for H7. Finish bed holes in the same way.
- Diameter and its allowance of dowel pin hole of the center way vary depending on the dimension table.
- Eliminate cutting chips and clean up again as necessary. When machines for mounting of the center way are large, clean them up with the center way removed and then reassemble.
- Load the dowel pins and check the parallelism of the reference surface of the running parallelism and the raceway of the center way again.

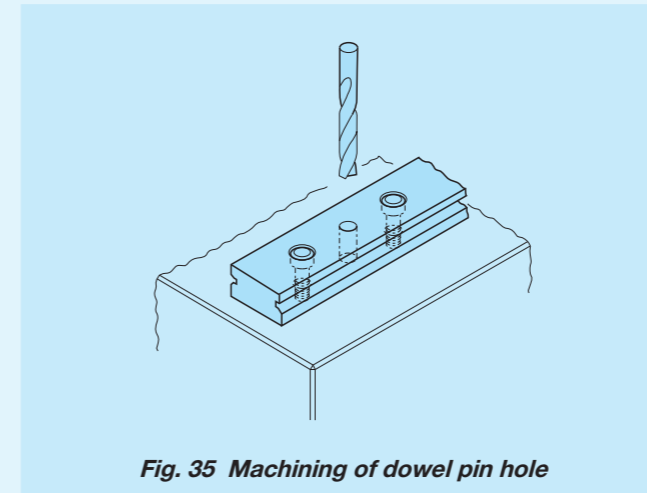

Fig. 35 Machining of dowel pin hole

5 Mounting of table-side way

- Follow the mounting of standard type CRW series.

6 Operation of table and bed

- Follow the mounting of standard type CRW series.

7 Preload adjustment

- Follow the mounting of standard type CRW series.

8 Full tightening of preload-adjustment-side way

- Follow the mounting of standard type CRW series.

9 Check after assembly

- Follow the mounting of standard type CRW series.

Mating marks module type CRW series

CRWM has mating marks to ensure the best running accuracy after mounting based on the parallelism measurement result of reference mounting surface and raceway. When assembling the ways, align the mating marks of ways with the same end side as indicated in Fig. 36.

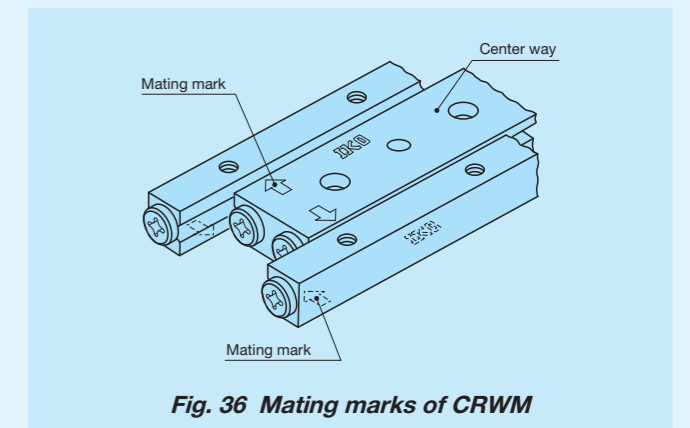
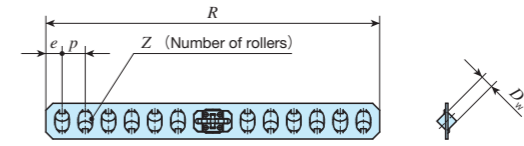
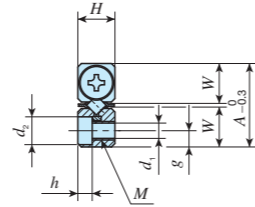
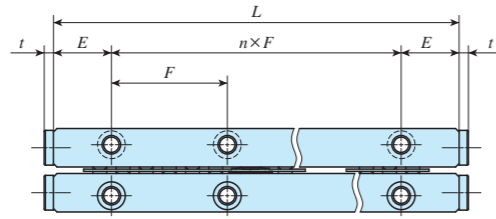

Fig. 36 Mating marks of CRWM

IKO Anti-Creep Cage Crossed Roller Way

Shape	CRWG			
Size	2	3	4	6



Identification number	Mass (Ref.)		Nominal dimensions mm																	Maximum stroke length mm	Basic dynamic load rating $C^{(3)}$ N	Basic static load rating $C_0^{(3)}$ N	Allowable load $F^{(3)}$ N
	Way ⁽¹⁾ g	Roller cage ⁽²⁾ g	Boundary dimensions				Dimension of roller cage				Mounting dimensions												
			A	H	$L(n \times F)$	E	D_w	R	Z	p	e	W	g	M	d_1	d_2	h	t					
CRWG 2- 30	6.53	0.38	12	6	30(1×15)	7.5	2	25.6	4	4	2.8	5.5	2.5	M3	2.55	4.4	2	1.5	9	913	1 180	392	
CRWG 2- 45	9.53	0.72			45(2×15)			41.6											8	7	1 570	2 350	783
CRWG 2- 60	12.5	0.88			60(3×15)			49.6											10	21	1 860	2 940	979
CRWG 2- 75	15.5	1.22			75(4×15)			65.6											14	19	2 420	4 110	1 370
CRWG 2- 90	18.5	1.39			90(5×15)			73.6											16	33	2 680	4 700	1 570
CRWG 2-105	21.5	1.72			105(6×15)			89.6											20	31	3 190	5 880	1 960
CRWG 2-120	24.5	1.89			120(7×15)			97.6											22	45	3 440	6 460	2 150
CRWG 2-135	27.5	2.22			135(8×15)			113.6											26	43	3 910	7 640	2 550
CRWG 2-150	30.5	2.39			150(9×15)			121.6											28	57	4 150	8 230	2 740
CRWG 3- 50	22.8	1.69			18			8											50(1×25)	12.5	3	42	6
CRWG 3- 75	33.3	2.71	75(2×25)	62		10	23		4 080	6 090	2 030												
CRWG 3-100	43.8	3.72	100(3×25)	82		14	33		5 300	8 530	2 840												
CRWG 3-125	54.4	4.74	125(4×25)	102		18	43		6 440	11 000	3 660												
CRWG 3-150	64.9	5.75	150(5×25)	122		22	53		7 530	13 400	4 470												
CRWG 3-175	75.4	6.77	175(6×25)	142		26	63		8 570	15 800	5 280												
CRWG 3-200	85.9	7.78	200(7×25)	162		30	73		9 580	18 300	6 090												
CRWG 3-225	96.4	8.80	225(8×25)	182		34	83		10 600	20 700	6 910												
CRWG 3-250	107	9.81	250(9×25)	202		38	93		11 500	23 200	7 720												

Notes ⁽¹⁾ The value shows the mass of a piece of way.
⁽²⁾ The value shows the mass of a roller cage.
⁽³⁾ This is the value when a combination of four ways and two roller cages is used in parallel arrangement.

CRW(G)(...H)
CRW(G)

IKO Anti-Creep Cage Crossed Roller Way

Shape	CRWG			
Size	2	3	4	6

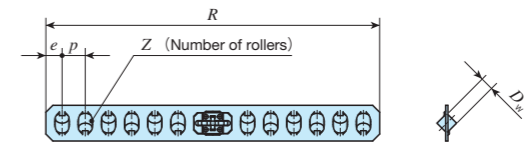
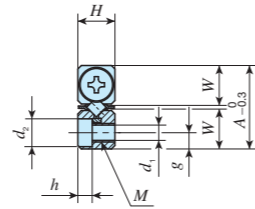
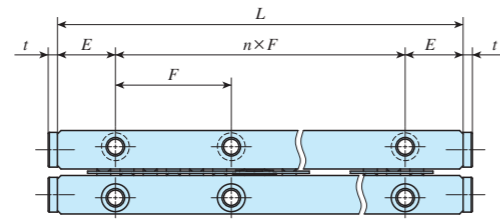

Identification number	Mass (Ref.)		Nominal dimensions mm																	Maximum stroke length mm	Basic dynamic load rating $C^{(3)}$ N	Basic static load rating $C_0^{(3)}$ N	Allowable load $F^{(3)}$ N
	Way ⁽¹⁾ g	Roller cage ⁽²⁾ g	Boundary dimensions				Dimension of roller cage				Mounting dimensions												
			A	H	$L(n \times F)$	E	D_w	R	Z	p	e	W	g	M	d_1	d_2	h	t					
CRWG 4- 80	59.6	9.70	22	11	80(1×40)	20	4	73	8	7	5	10	4.5	M5	4.3	7.5	4.1	2	14	6 690	9 400	3 130	
CRWG 4-120	88.0	12.0			120(2×40)			101	12										38	9 180	14 100	4 700	
CRWG 4-160	116	14.3			160(3×40)			129	16										62	11 500	18 800	6 270	
CRWG 4-200	145	16.7			200(4×40)			157	20										86	13 700	23 500	7 830	
CRWG 4-240	173	20.1			240(5×40)			199	26										82	16 700	30 600	10 200	
CRWG 4-280	201	22.5			280(6×40)			227	30										106	18 700	35 300	11 800	
CRWG 4-320	230	24.8			320(7×40)			255	34										129	20 600	40 000	13 300	
CRWG 6-100	147	12.0	31	15	100(1×50)	25	6	75	6	9	6	14	6	M6	5.3	9.5	5.2	3	48	11 200	13 800	4 610	
CRWG 6-150	216	22.6			150(2×50)			129	12										40	19 300	27 700	9 230	
CRWG 6-200	285	29.7			200(3×50)			165	16										68	24 100	36 900	12 300	
CRWG 6-250	353	36.8			250(4×50)			201	20										96	28 700	46 100	15 400	
CRWG 6-300	422	43.9			300(5×50)			237	24										124	33 000	55 400	18 500	
CRWG 6-350	491	51.0			350(6×50)			273	28										151	37 200	64 600	21 500	

Notes ⁽¹⁾ The value shows the mass of a piece of way.
⁽²⁾ The value shows the mass of a roller cage.
⁽³⁾ This is the value when a combination of four ways and two roller cages is used in parallel arrangement.

CRW(G)(...H)
CRWU(G)

IKO Anti-Creep Cage Crossed Roller Way H

Shape	CRWG...H			
Size	1	2	3	4

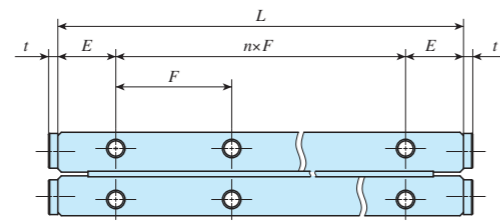

CRWG 1...H

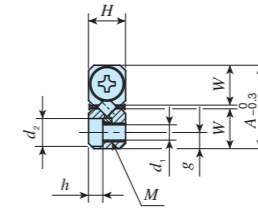
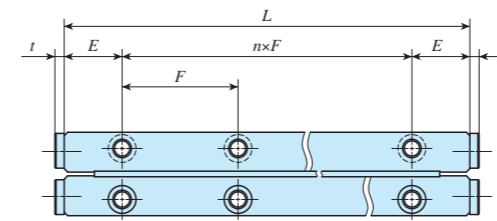
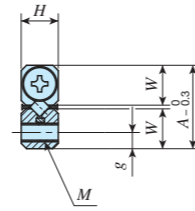

CRWG...H

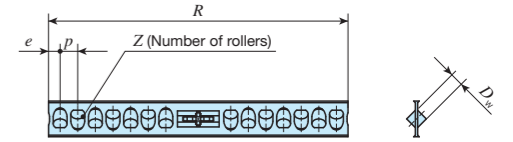

Identification number	Mass (Ref.)		Nominal dimensions mm																	Maximum stroke length mm	Basic dynamic load rating $C_0^{(3)}$ N	Basic static load rating $C_0^{(3)}$ N	Allowable load $F^{(3)}$ N
	Way ⁽¹⁾ g	Roller cage ⁽²⁾ g	Boundary dimensions				Dimension of roller cage				Mounting dimensions												
			A	H	$L(n \times F)$	E	D_w	R	Z	p	e	W	g	M	d_1	d_2	h	t					
CRWG 1- 20H	2.05	0.16	8.5	4	20(1×10)	5	1.5	16.5	6	2	1.25	3.9	1.7	M1.6	-	-	-	0.7	3	525	717	239	
CRWG 1- 30H	3.07	0.25			30(2×10)			24.5											10	7	782	1 200	398
CRWG 1- 40H	4.10	0.30			40(3×10)			28.5											12	19	901	1 430	478
CRWG 1- 50H	5.13	0.39			50(4×10)			36.5											16	23	1 130	1 910	638
CRWG 1- 60H	6.15	0.44			60(5×10)			40.5											18	35	1 230	2 150	717
CRWG 1- 70H	7.18	0.53			70(6×10)			48.5											22	39	1 440	2 630	877
CRWG 1- 80H	8.21	0.67			80(7×10)			61.5											28	35	1 740	3 350	1 120
CRWG 2- 30H	6.53	0.40			12			6											30(1×15)	7.5	2	21.7	6
CRWG 2- 45H	9.53	0.73	45(2×15)	36.7		12	12		1 860	3 000	1 000												
CRWG 2- 60H	12.5	0.95	60(3×15)	46.7		16	22		2 330	4 000	1 330												
CRWG 2- 75H	15.5	1.27	75(4×15)	61.7		22	22		2 980	5 500	1 830												
CRWG 2- 90H	18.5	1.38	90(5×15)	66.7		24	42		3 190	6 000	2 000												
CRWG 2-105H	21.5	1.71	105(6×15)	81.7		30	42		3 790	7 500	2 500												
CRWG 2-120H	24.5	1.93	120(7×15)	91.7		34	52		4 180	8 500	2 830												
CRWG 2-135H	27.5	2.26	135(8×15)	106.7		40	52		4 740	10 000	3 330												
CRWG 2-150H	30.5	2.48	150(9×15)	117.5	44	62	5 100	11 000	3 670														
CRWG 3- 50H	22.8	1.58	18	8	50(1×25)	12.5	3	41.8	8	3.8	2.5	8.6	3.5	M4	3.3	6	3.1	2	13	4 260	6 490	2 160	
CRWG 3- 75H	33.7	2.28			75(2×25)			57											12	29	5 840	9 730	3 240
CRWG 3-100H	44.7	3.33			100(3×25)			79.8											18	33	8 000	14 600	4 870
CRWG 3-125H	55.7	4.02			125(4×25)			95											22	53	9 350	17 800	5 950
CRWG 3-150H	66.7	5.07			150(5×25)			117.8											28	57	11 300	22 700	7 570
CRWG 3-175H	77.6	5.69			175(6×25)			133											32	77	12 500	26 000	8 650
CRWG 3-200H	88.6	6.81			200(7×25)			155.8											38	81	14 300	30 800	10 300
CRWG 3-225H	99.6	7.85			225(8×25)			178.6											44	86	16 000	35 700	11 900
CRWG 3-250H	111	8.55	250(9×25)	193.8	48	105	17 100	38 900	13 000														
CRWG 4- 80H	61.4	4.35	22	11	80(1×40)	20	4	59.4	10	4.8	3	10.6	4.5	M5	4.3	7.5	4.1	2	33	10 500	17 100	5 690	
CRWG 4-120H	92.7	6.80			120(2×40)			88.2											16	55	15 200	27 300	9 100
CRWG 4-160H	124	9.25			160(3×40)			117											22	78	19 500	37 500	12 500
CRWG 4-200H	155	11.7			200(4×40)			145.8											28	100	23 500	47 800	15 900
CRWG 4-240H	186	15.0			240(5×40)			184.2											36	103	28 600	61 400	20 500
CRWG 4-280H	218	17.4			280(6×40)			213											42	126	32 200	71 700	23 900
CRWG 4-320H	249	19.9	320(7×40)	241.8	48	148	35 700	81 900	27 300														

Notes ⁽¹⁾ The value shows the mass of a piece of way.
⁽²⁾ The value shows the mass of a roller cage.
⁽³⁾ This is the value when a combination of four ways and two roller cages is used in parallel arrangement.

IKO Crossed Roller Way

Standard type					
Shape	CRW CRW...SL				
Size	1	2	3	4	6
	9	12	15	18	24

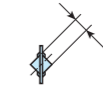
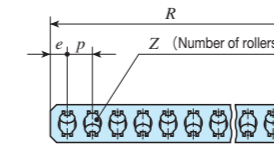
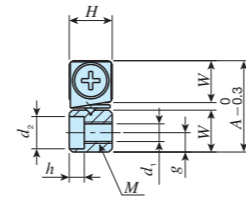
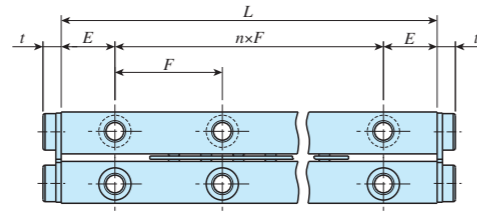

Identification number	Mass (Ref.)		Nominal dimensions mm																	Basic dynamic load rating $C_U^{(3)}$ N	Basic static load rating $C_{0U}^{(3)}$ N	Allowable load $F_U^{(3)}$ N
	Way ⁽¹⁾ kg/m	Roller cage ⁽²⁾ g	Boundary dimensions				Dimension of roller cage			Mounting dimensions												
			A	H	$L(n \times F)$	E	D_w	R	Z	p	e	W	g	M	d_1	d_2	h	t				
CRW 1- 20	0.12	0.38	8.5	4	20 (1×10)	5	1.5	16.5	3	2.25	3.9	1.8	M2	1.65	3	1.4	1.7	125	120	39.8		
CRW 1- 20 SL					30 (2×10)			25.5													8	
CRW 1- 30					40 (3×10)			31.5													10	
CRW 1- 30 SL					50 (4×10)			37.5													12	
CRW 1- 40					60 (5×10)			43.5													14	
CRW 1- 40 SL					70 (6×10)			52.5													17	
CRW 1- 50					80 (7×10)			61.5													20	
CRW 1- 50 SL																						
CRW 1- 60																						
CRW 1- 60 SL																						
CRW 1- 70																						
CRW 1- 70 SL																						
CRW 1- 80																						
CRW 1- 80 SL																						

Notes ⁽¹⁾ The value shows the mass per meter of a way.
⁽²⁾ The value shows the mass of a roller cage with ten cylindrical rollers.
⁽³⁾ The value shows the load of a cylindrical roller.

CRW(G)(...H)
CRWU(G)

IKO Crossed Roller Way

Standard type					
Shape	CRW CRW...SL				
Size	1	2	3	4	6
	9	12	15	18	24

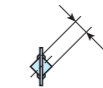
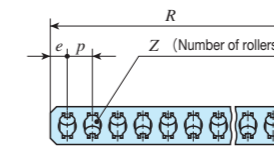
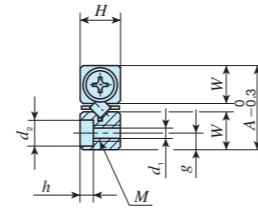
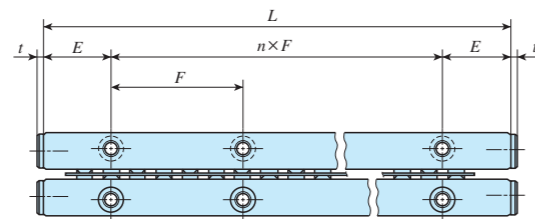

Identification number	Mass (Ref.)		Nominal dimensions mm																	Basic dynamic load rating $C_U^{(2)}$ N	Basic static load rating $C_{0U}^{(3)}$ N	Allowable load $F_U^{(3)}$ N
	Way ⁽¹⁾ kg/m	Roller cage ⁽²⁾ g	Boundary dimensions				Dimension of roller cage			Mounting dimensions												
			A	H	$L(n \times F)$	E	D_w	R	Z	p	e	W	g	M	d_1	d_2	h	t				
CRW 2- 30	0.24	0.98	12	6	30 (1×15)	7.5	2	29.6	4	2.8	5.5	2.5	M3	2.55	4.4	2	1.5	293	294	97.9		
CRW 2- 30 SL																						
CRW 2- 45					45 (2×15)			41.6													10	
CRW 2- 45 SL																						
CRW 2- 60					60 (3×15)			53.6													13	
CRW 2- 60 SL																						
CRW 2- 75					75 (4×15)			65.6													16	
CRW 2- 75 SL																						
CRW 2- 90					90 (5×15)			77.6													19	
CRW 2- 90 SL																						
CRW 2-105					105 (6×15)			89.6													22	
CRW 2-105 SL																						
CRW 2-120					120 (7×15)			101.6													25	
CRW 2-120 SL																						
CRW 2-135					135 (8×15)			113.6													28	
CRW 2-135 SL																						
CRW 2-150					150 (9×15)			125.6													31	
CRW 2-150 SL																						
CRW 2-165	165 (10×15)	137.6	34																			
CRW 2-165 SL																						
CRW 2-180	180 (11×15)	149.6	37																			
CRW 2-180 SL																						

Notes ⁽¹⁾ The value shows the mass per meter of a way.
⁽²⁾ The value shows the mass of a roller cage with ten cylindrical rollers.
⁽³⁾ The value shows the load of a cylindrical roller.

IKO Crossed Roller Way

Standard type											
Shape	CRW CRW...SL										
Size	<table border="1"> <tr> <td>1</td> <td>2</td> <td>3</td> <td>4</td> <td>6</td> </tr> <tr> <td>9</td> <td>12</td> <td>15</td> <td>18</td> <td>24</td> </tr> </table>	1	2	3	4	6	9	12	15	18	24
1	2	3	4	6							
9	12	15	18	24							

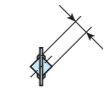
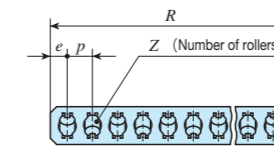
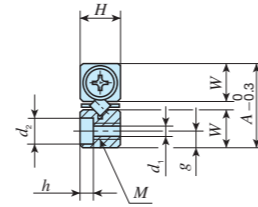
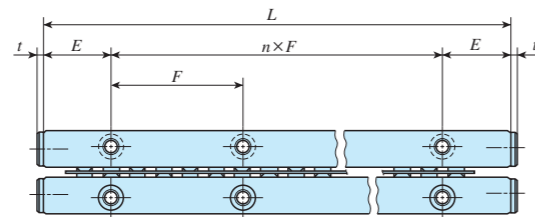

Identification number	Mass (Ref.)		Nominal dimensions mm																	Basic dynamic load rating $C_U^{(3)}$ N	Basic static load rating $C_{0U}^{(3)}$ N	Allowable load $F_U^{(3)}$ N																	
	Way ⁽¹⁾ kg/m	Roller cage ⁽²⁾ g	Boundary dimensions			Dimension of roller cage			Mounting dimensions																														
			A	H	$L(n \times F)$	E	D_w	R	Z	p	e	W	g	M	d_1	d_2	h	t																					
CRW 3- 50	0.50	2.96	18	8	50 (1×25)	12.5	3	42	8	5	3.5	8.3	3.5	M4	3.3	6	3.1	2	638	609	203																		
CRW 3- 50 SL																																							
CRW 3- 75																							75 (2×25)			62	12												
CRW 3- 75 SL																																							
CRW 3-100																							100 (3×25)			82	16												
CRW 3-100 SL																																							
CRW 3-125																							125 (4×25)			102	20												
CRW 3-125 SL																																							
CRW 3-150																							150 (5×25)			122	24												
CRW 3-150 SL																																							
CRW 3-175																							175 (6×25)			142	28												
CRW 3-175 SL																																							
CRW 3-200																							200 (7×25)			162	32												
CRW 3-200 SL																																							
CRW 3-225																							225 (8×25)			182	36												
CRW 3-225 SL																																							
CRW 3-250																							250 (9×25)			202	40												
CRW 3-250 SL																																							
CRW 3-275					275 (10×25)			222	44																														
CRW 3-275 SL																																							
CRW 3-300					300 (11×25)			242	48																														
CRW 3-300 SL																																							

Notes ⁽¹⁾ The value shows the mass per meter of a way.
⁽²⁾ The value shows the mass of a roller cage with ten cylindrical rollers.
⁽³⁾ The value shows the load of a cylindrical roller.

CRW(G)(...H)
CRWU(G)

IKO Crossed Roller Way

Standard type					
Shape	CRW CRW...SL				
Size	1	2	3	4	6
	9	12	15	18	24

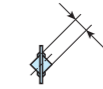
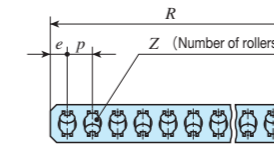
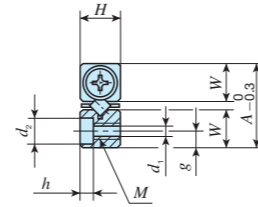
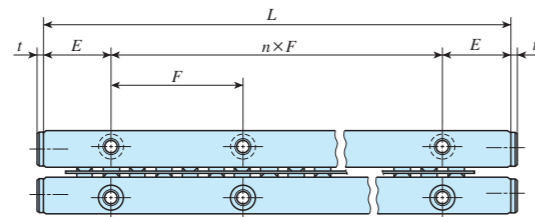

Identification number	Mass (Ref.)		Nominal dimensions mm																	Basic dynamic load rating $C_U^{(3)}$ N	Basic static load rating $C_{0U}^{(3)}$ N	Allowable load $F_U^{(3)}$ N																	
	Way ⁽¹⁾ kg/m	Roller cage ⁽²⁾ g	Boundary dimensions				Dimension of roller cage			Mounting dimensions																													
			A	H	$L(n \times F)$	E	D_w	R	Z	p	e	W	g	M	d_1	d_2	h	t																					
CRW 4- 80	0.82	6.91	22	11	80 (1×40)	20	4	73	10	7	5	10	4.5	M5	4.3	7.5	4.1	2	1 230	1 180	392																		
CRW 4- 80 SL																																							
CRW 4-120																							120 (2×40)			101	14												
CRW 4-120 SL																																							
CRW 4-160																							160 (3×40)			136	19												
CRW 4-160 SL																																							
CRW 4-200																							200 (4×40)			164	23												
CRW 4-200 SL																																							
CRW 4-240																							240 (5×40)			199	28												
CRW 4-240 SL																																							
CRW 4-280																							280 (6×40)			227	32												
CRW 4-280 SL																																							
CRW 4-320																							320 (7×40)			262	37												
CRW 4-320 SL																																							
CRW 4-360																							360 (8×40)			297	42												
CRW 4-360 SL																																							
CRW 4-400																							400 (9×40)			325	46												
CRW 4-400 SL																																							
CRW 4-440					440 (10×40)			360	51																														
CRW 4-440 SL																																							
CRW 4-480					480 (11×40)			388	55																														
CRW 4-480 SL																																							

Notes ⁽¹⁾ The value shows the mass per meter of a way.
⁽²⁾ The value shows the mass of a roller cage with ten cylindrical rollers.
⁽³⁾ The value shows the load of a cylindrical roller.

CRW(G)(...H)
CRW(G)

IKO Crossed Roller Way

Standard type	
Shape	CRW CRW...SL
Size	1 2 3 4 6
	9 12 15 18 24

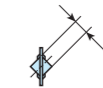
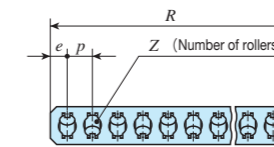
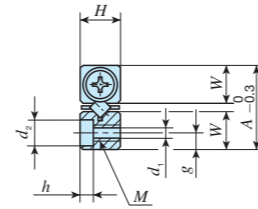
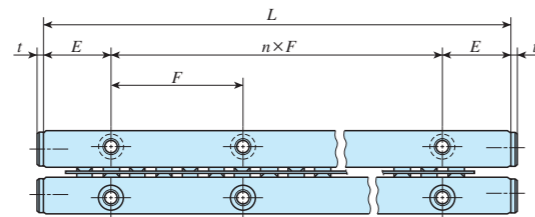

Identification number	Mass (Ref.)		Nominal dimensions mm																	Basic dynamic load rating $C_U^{(3)}$ N	Basic static load rating $C_{0U}^{(3)}$ N	Allowable load $F_U^{(3)}$ N
	Way ⁽¹⁾ kg/m	Roller cage ⁽²⁾ g	Boundary dimensions				Dimension of roller cage			Mounting dimensions												
			A	H	$L(n \times F)$	E	D_w	R	Z	p	e	W	g	M	d_1	d_2	h	t				
CRW 6-100	1.57	20.3	31	15	100 (1×50)	25	6	84	9	9	6	14	6	M6	5.3	9.5	5.2	3	2 570	2 310	769	
CRW 6-100 SL																						
CRW 6-150					150 (2×50)			129	14													
CRW 6-150 SL																						
CRW 6-200					200 (3×50)			165	18													
CRW 6-200 SL																						
CRW 6-250					250 (4×50)			210	23													
CRW 6-250 SL																						
CRW 6-300					300 (5×50)			246	27													
CRW 6-300 SL																						
CRW 6-350					350 (6×50)			282	31													
CRW 6-350 SL																						
CRW 6-400					400 (7×50)			327	36													
CRW 6-400 SL																						
CRW 6-450					450 (8×50)			363	40													
CRW 6-450 SL																						
CRW 6-500					500 (9×50)			408	45													
CRW 6-500 SL																						
CRW 6-550	550 (10×50)	444	49																			
CRW 6-550 SL																						
CRW 6-600	600 (11×50)	489	54																			
CRW 6-600 SL																						

Notes ⁽¹⁾ The value shows the mass per meter of a way.
⁽²⁾ The value shows the mass of a roller cage with ten cylindrical rollers.
⁽³⁾ The value shows the load of a cylindrical roller.

CRW(G)(...H)
CRW(G)

IKO Crossed Roller Way

Standard type					
Shape	CRW				
Size	1	2	3	4	6
	9	12	15	18	24

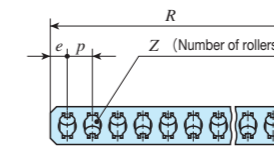
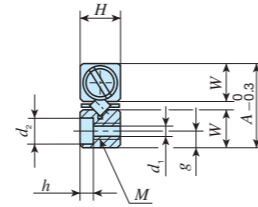
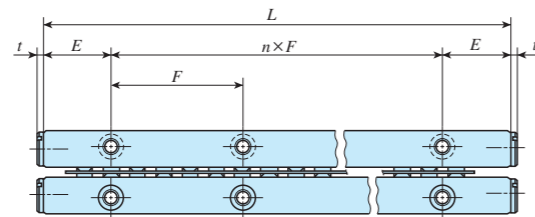

Identification number	Mass (Ref.)		Nominal dimensions mm																	Basic dynamic load rating $C_U^{(3)}$ N	Basic static load rating $C_{0U}^{(3)}$ N	Allowable load $F_U^{(3)}$ N
	Way ⁽¹⁾ kg/m	Roller cage ⁽²⁾ g	Boundary dimensions				Dimension of roller cage				Mounting dimensions											
			A	H	$L(n \times F)$	E	D_w	R	Z	p	e	W	g	M	d_1	d_2	h	t				
CRW 9- 200	3.3	64.8	44	22	200 (1×100)	50	9	173	12	14	9.5	20.2	9	M 8	6.8	10.5	6.2	3	7 190	6 600	2 200	
CRW 9- 300					300 (2×100)			257	18													
CRW 9- 400					400 (3×100)			327	23													
CRW 9- 500					500 (4×100)			411	29													
CRW 9- 600					600 (5×100)			495	35													
CRW 9- 700					700 (6×100)			565	40													
CRW 9- 800					800 (7×100)			649	46													
CRW 9- 900					900 (8×100)			733	52													
CRW 9-1000					1 000 (9×100)			817	58													
CRW 9-1100					1 100 (10×100)			887	63													
CRW 9-1200					1 200 (11×100)			971	69													
CRW 12- 200	5.57	146	58	28	200 (1×100)	50	12	168	9	18	12	26.9	12	M10	8.5	13.5	8.2	3	14 700	13 600	4 540	
CRW 12- 300					300 (2×100)			258	14													
CRW 12- 400					400 (3×100)			330	18													
CRW 12- 500					500 (4×100)			420	23													
CRW 12- 600					600 (5×100)			492	27													
CRW 12- 700					700 (6×100)			564	31													
CRW 12- 800					800 (7×100)			654	36													
CRW 12- 900					900 (8×100)			726	40													
CRW 12-1000					1 000 (9×100)			816	45													
CRW 12-1100					1 100 (10×100)			888	49													
CRW 12-1200					1 200 (11×100)			978	54													

Notes ⁽¹⁾ The value shows the mass per meter of a way.
⁽²⁾ The value shows the mass of a roller cage with ten cylindrical rollers.
⁽³⁾ The value shows the load of a cylindrical roller.

IKO Crossed Roller Way

Standard type					
Shape	CRW				
Size	1	2	3	4	6
	9	12	15	18	24

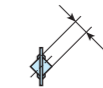
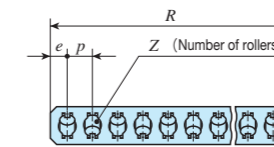
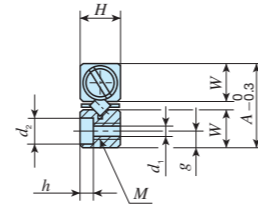
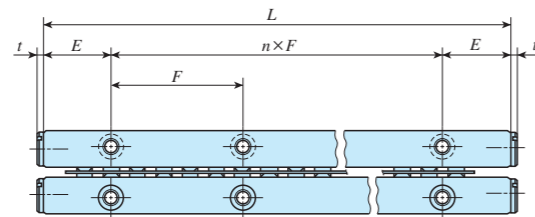

Identification number	Mass (Ref.)		Nominal dimensions mm																	Basic dynamic load rating $C_U^{(3)}$ N	Basic static load rating $C_{0U}^{(3)}$ N	Allowable load $F_U^{(3)}$ N
	Way ⁽¹⁾ kg/m	Roller cage ⁽²⁾ g	Boundary dimensions				Dimension of roller cage				Mounting dimensions											
			A	H	$L(n \times F)$	E	D_w	R	Z	p	e	W	g	M	d_1	d_2	h	t				
CRW 15-300*	8.75	273	71	36	300 (2×100)	50	15	261	11	23	15.5	33	14	M12	10.5	16.5	10.2	5	23 800	21 900	7 300	
CRW 15-400*					400 (3×100)			330	14													
CRW 15-500*					500 (4×100)			422	18													
CRW 15-600*					600 (5×100)			491	21													
CRW 15-700*					700 (6×100)			583	25													
CRW 15-800*					800 (7×100)			652	28													
CRW 15-900*					900 (8×100)			744	32													
CRW 15-1000*					1 000 (9×100)			813	35													
CRW 15-1100*					1 100 (10×100)			905	39													
CRW 15-1200*					1 200 (11×100)			974	42													
CRW 18-300*	11.3	447	83	40	300 (2×100)	50	18	262	9	28	19	38.5	18	M14	12.5	18.5	12.2	5	35 800	32 700	10 900	
CRW 18-400*					400 (3×100)			346	12													
CRW 18-500*					500 (4×100)			430	15													
CRW 18-600*					600 (5×100)			514	18													
CRW 18-700*					700 (6×100)			570	20													
CRW 18-800*					800 (7×100)			654	23													
CRW 18-900*					900 (8×100)			738	26													
CRW 18-1000*					1 000 (9×100)			822	29													
CRW 18-1100*					1 100 (10×100)			906	32													
CRW 18-1200*					1 200 (11×100)			990	35													

Notes ⁽¹⁾ The value shows the mass per meter of a way.
⁽²⁾ The value shows the mass of a roller cage with ten cylindrical rollers.
⁽³⁾ The value shows the load of a cylindrical roller.
 Remark: The identification numbers with * are our semi-standard items.

CRW(G)(...H)
CRWU(G)

IKO Crossed Roller Way

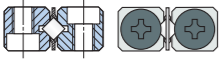
Standard type											
Shape	CRW 										
Size	<table border="1"> <tr> <td>1</td> <td>2</td> <td>3</td> <td>4</td> <td>6</td> </tr> <tr> <td>9</td> <td>12</td> <td>15</td> <td>18</td> <td>24</td> </tr> </table>	1	2	3	4	6	9	12	15	18	24
1	2	3	4	6							
9	12	15	18	24							

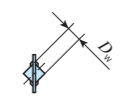
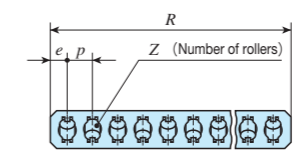
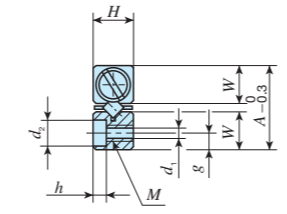
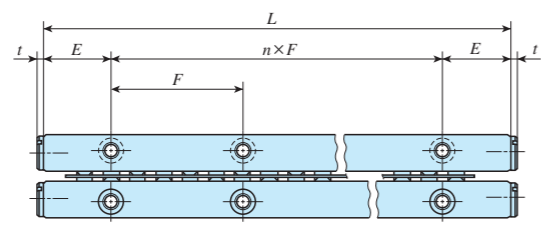

Identification number	Mass (Ref.)		Nominal dimensions mm																	Basic dynamic load rating $C_U^{(2)}$ N	Basic static load rating $C_{0U}^{(3)}$ N	Allowable load $F_U^{(3)}$ N
	Way ⁽¹⁾ kg/m	Roller cage ⁽²⁾ g	Boundary dimensions			Dimension of roller cage			Mounting dimensions													
			A	H	$L(n \times F)$	E	D_w	R	Z	p	e	W	g	M	d_1	d_2	h	t				
CRW 24- 400*	20.6	1 060	110	55	400 (3×100)	50	24	336	9	36	24	51.5	24	M16	14.5	22.5	14.2	5	69 600	63 500	21 200	
CRW 24- 500*					500 (4×100)			408	11													
CRW 24- 600*					600 (5×100)			516	14													
CRW 24- 700*					700 (6×100)			588	16													
CRW 24- 800*					800 (7×100)			660	18													
CRW 24- 900*					900 (8×100)			732	20													
CRW 24-1000*					1 000 (9×100)			840	23													
CRW 24-1100*					1 100 (10×100)			912	25													
CRW 24-1200*					1 200 (11×100)			984	27													

Notes ⁽¹⁾ The value shows the mass per meter of a way.
⁽²⁾ The value shows the mass of a roller cage with ten cylindrical rollers.
⁽³⁾ The value shows the load of a cylindrical roller.
 Remark: The identification numbers with * are our semi-standard items.

CRW(G)(...H)
CRWU(G)

IKO Crossed Roller Way

Module type				
Shape	CRWM			
Size	1	2	3	4

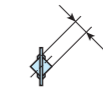
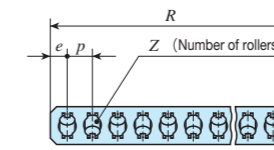
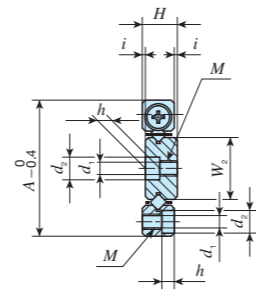
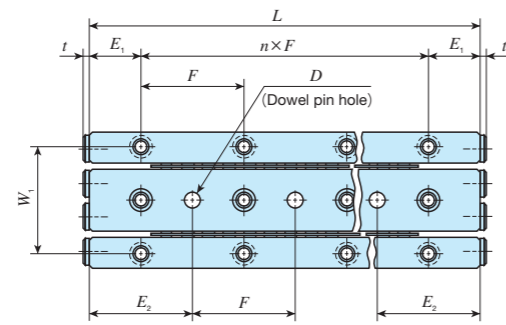

Identification number	Mass (Ref.)		Nominal dimensions and tolerances mm																				Basic dynamic load rating $C_U^{(2)}$ N	Basic static load rating $C_{0U}^{(2)}$ N	Allowable load $F_U^{(3)}$ N		
	Way ⁽¹⁾ kg/m	Roller cage ⁽²⁾ g	Boundary dimensions				Dimension of roller cage				Mounting dimensions																
			A	H	$L(n \times F)$	i	D_w	R	Z	p	e	W_1	W_2	E_1	E_2	M	d_1	d_2	h	D	Dim. D tolerance	t					
CRWM 1- 20	0.49	0.38	17	4.5	20 (1×10)	0.5	1.5	16.5	5	3	2.25	13.4	7.8	5	10	M2	1.65	3	1.4	2	+0.010 0	1.7	125	120	39.8		
CRWM 1- 30					30 (2×10)																					25.5	8
CRWM 1- 40					40 (3×10)																					31.5	10
CRWM 1- 50					50 (4×10)																					37.5	12
CRWM 1- 60					60 (5×10)																					43.5	14
CRWM 1- 70					70 (6×10)																					52.5	17
CRWM 1- 80					80 (7×10)																					61.5	20
CRWM 2- 30	0.99	0.98	24	6.5	30 (1×15)	0.5	2	29.6	7	4	2.8	19	11	7.5	15	M3	2.55	4.4	2	3	+0.010 0	1.5	293	294	97.9		
CRWM 2- 45					45 (2×15)																					41.6	10
CRWM 2- 60					60 (3×15)																					53.6	13
CRWM 2- 75					75 (4×15)																					65.6	16
CRWM 2- 90					90 (5×15)																					77.6	19
CRWM 2-105					105 (6×15)																					89.6	22
CRWM 2-120					120 (7×15)																					101.6	25
CRWM 2-135					135 (8×15)																					113.6	28
CRWM 2-150					150 (9×15)																					125.6	31
CRWM 2-165					165 (10×15)																					137.6	34
CRWM 2-180	180 (11×15)	149.6	37																								

Notes ⁽¹⁾ The value shows the total mass per meter of a set of three ways.
⁽²⁾ The value shows the mass of a roller cage with ten cylindrical rollers.
⁽³⁾ The value shows the load of a cylindrical roller.

CRW(G)(...H)
CRWU(G)

IKO Crossed Roller Way

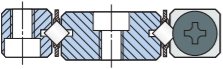
Module type				
Shape	CRWM			
				
Size	1	2	3	4

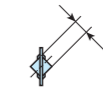
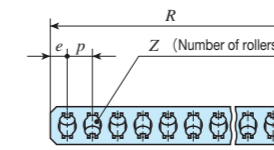
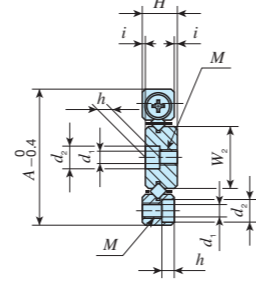
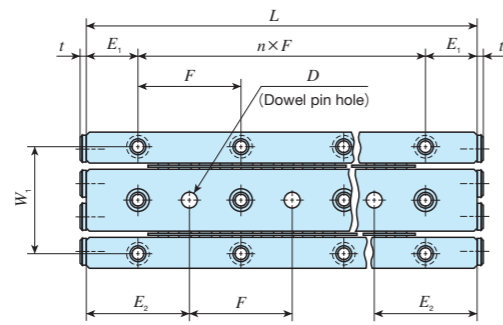

Identification number	Mass (Ref.)		Nominal dimensions and tolerances mm																				Basic dynamic load rating $C_U^{(2)}$ N	Basic static load rating $C_{0U}^{(2)}$ N	Allowable load $F_U^{(3)}$ N
	Way ⁽¹⁾ kg/m	Roller cage ⁽²⁾ g	Boundary dimensions				Dimension of roller cage				Mounting dimensions														
			A	H	$L(n \times F)$	i	D_w	R	Z	p	e	W_1	W_2	E_1	E_2	M	d_1	d_2	h	D	Dim. D tolerance	t			
CRWM 3- 50	1.99	2.96	36	8.5	50 (1×25)	0.5	3	42	8	5	3.5	29	16.6	12.5	25	M4	3.3	6	3.1	4	+0.012 0	2	638	609	203
CRWM 3- 75					75 (2×25)			62	12																
CRWM 3-100					100 (3×25)			82	16																
CRWM 3-125					125 (4×25)			102	20																
CRWM 3-150					150 (5×25)			122	24																
CRWM 3-175					175 (6×25)			142	28																
CRWM 3-200					200 (7×25)			162	32																
CRWM 3-225					225 (8×25)			182	36																
CRWM 3-250					250 (9×25)			202	40																
CRWM 3-275					275 (10×25)			222	44																
CRWM 3-300					300 (11×25)			242	48																
CRWM 4- 80	3.28	6.91	44	11.5	80 (1×40)	0.5	4	73	10	7	5	35	20	20	40	M5	4.3	7.5	4.1	5	+0.012 0	2	1 230	1 180	392
CRWM 4-120					120 (2×40)			101	14																
CRWM 4-160					160 (3×40)			136	19																
CRWM 4-200					200 (4×40)			164	23																
CRWM 4-240					240 (5×40)			199	28																
CRWM 4-280					280 (6×40)			227	32																
CRWM 4-320					320 (7×40)			262	37																
CRWM 4-360					360 (8×40)			297	42																
CRWM 4-400					400 (9×40)			325	46																
CRWM 4-440					440 (10×40)			360	51																
CRWM 4-480					480 (11×40)			388	55																

Notes ⁽¹⁾ The value shows the total mass per meter of a set of three ways.
⁽²⁾ The value shows the mass of a roller cage with ten cylindrical rollers.
⁽³⁾ The value shows the load of a cylindrical roller.

CRW(G)(...H)
CRWU(G)



Anti-Creep Cage Crossed Roller Way Unit

CRWUG



Identification Number and Specification

Example of an identification number

The specification of CRWUG and CRWU series is indicated by the identification number. Indicate the identification number, consisting of a model code, width, and length for each specification to apply.

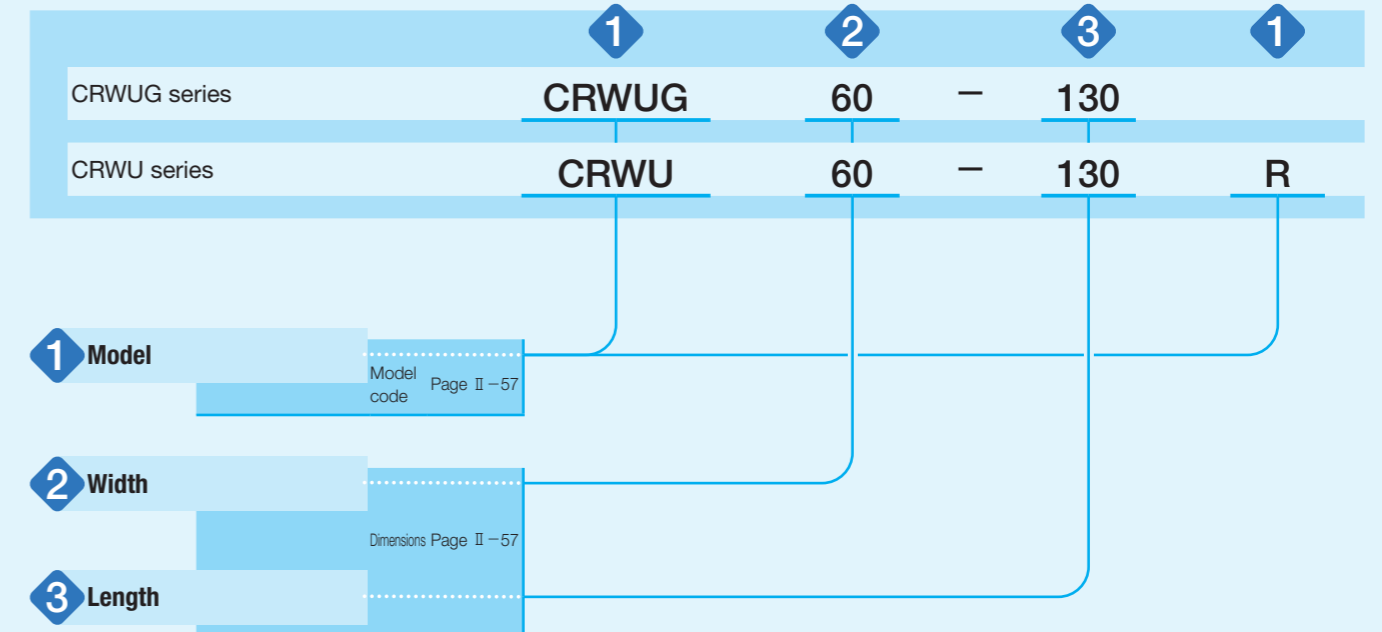

CRW(G)(...H)
CRWU(G)

Points

● High rigidity and high accuracy

Since CRWG or CRW with excellent load balance is incorporated with grounded high rigidity table and bed, elastic deformation is small for load in every direction, leading to highly accurate and stable linear motion.

● Wide variation

Three types of CRWU with different sectional shapes are available with many size variations. You can select an optimal linear bushing for the specifications of your machine and device.

● Solves cage creep issue

As CRWG with cage creep proof function is incorporated with CRWUG, there is no risk of cage creep and it works reliable in high-speed and high-tact operation, or in vertical axis.

● Easy mounting

Mounting surface is precisely grounded. In addition, female screws and boring are used for table and bed, respectively to ensure appropriate preload state. Therefore, highly reliable linear motion can be achieved just by fitting them to the machine and device.

Identification Number and Specification

1 Model	Anti-Creep Cage Crossed Roller Way Unit (CRWUG series)	: CRWUG
	Crossed Roller Way Unit (CRWU series)	: CRWU : CRWU...R : CRWU...RS
	For applicable models and width, see Fig. 1.	
2 Width	20, 30, 40, 60, 80, 100, 145	Indicate the table width in mm. For applicable models and width, see Fig. 1.
3 Length		Indicate the table length in mm.

Table 1 Models and width of CRWUG series and CRWU series

Series	Shape	Model	Characteristics	Width						
				20	30	40	60	80	100	145
CRWUG		CRWUG	A unit with cage creep proof function that realizes complete compatibility with CRWU in mounting dimensions. As external dimensions are the same, this can replace machine or device using CRWU without changing mounting dimensions, as well as new applications.	-	-	○	○	○	-	-
CRWU		CRWU	An ordinary type unit to be fixed to machine or device with bolts as it is, thanks to table and bed mounted to high accuracy.	-	○	○	○	○	○	○
		CRWU...R	Low height unit without CRWU bed. Linear motion with stable accuracy and high rigidity can be achieved for load in every direction.	-	○	○	○	○	○	○
		CRWU...RS	A compact and light unit of very simple structure. This may be used as a high-accuracy unit with small motion inertia by moving the center way.	○	○	○	-	-	-	-

Load Rating and Allowable Load

Indicate values for down direction for load rating of CRWUG and CRWU series.
In addition, the upward and lateral load rating is the same as downward load rating.
For more information on the definition of load rating and calculated load, see page III-3.

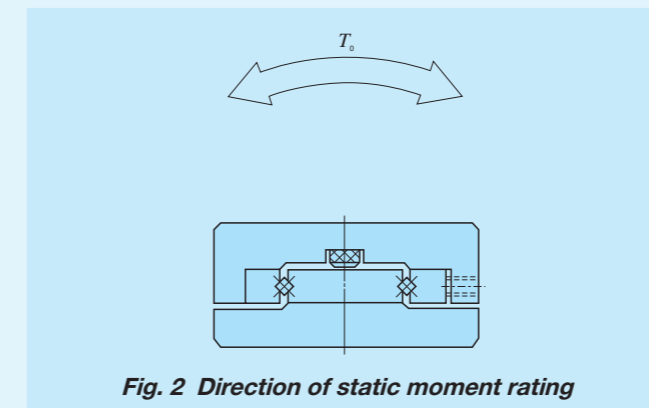
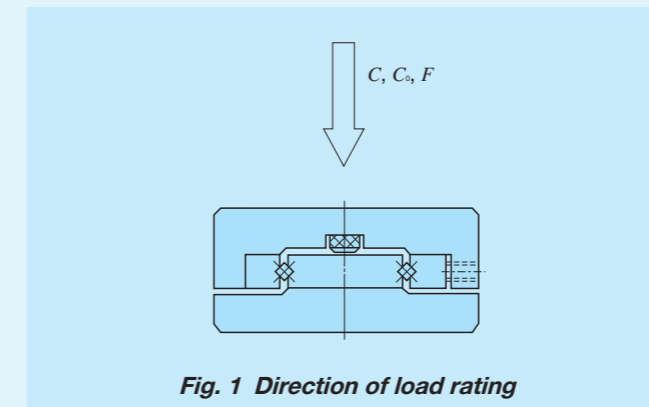

Allowable load

Allowable load refers to load of smooth rolling motion on contact surface to which maximum contact stress is applied and the sum of whose elastic deformation of rolling elements and raceway is small.
Therefore, use applied load within the allowable load range if very smooth rolling motion and high accuracy are required.

Accuracy

Accuracy of CRWUG series and CRWU series is indicated in Table 2. Parallelism at the center of the table represents parallelism of height when the table is stroked.
Parallelism at the side of the table represents parallelism of the side (preload adjusting screw side) when the table is stroked.
In addition, though allowance of unit height H is designed as ± 0.1 mm, units with height variation of less than 0.01 mm among multiple units are also available. When special accuracy is needed, contact **IKO**.

Table 2 Running accuracy

unit: μm

Unit length L mm	Parallelism at the table center	Parallelism on the table side
Over	Incl.	
-	50	4
50	100	5
100	160	6
160	310	7
310	510	8
510	710	9
710	-	10

Lubrication

Grease is not pre-packed in the CRWUG series and CRWU series, so please perform adequate lubrication as needed. Both of oil lubrication and grease lubrication are available in the CRWUG series and CRWU series. Generally, oil lubrication should be selected for high speed or low frictional resistance, and grease lubrication for low speed. For grease lubrication, use of high-quality lithium-soap base grease is recommended.

Dust Protection

Since the CRWUG series and CRWU series are finished with high accuracy, harmful foreign substances such as dust and particles entering into the bearing will cause low life or impaired accuracy. For applications in other than clean environment, cover the entire unit with a protective case, etc. to prevent harmful foreign substances such as dust, particles and water from outside from entering.

Precaution for Use

1 Handling

As the CRWUG series and CRWU series are designed highly precisely, take extra care for handling.

Cage of the CRWUG series has a pinion gear incorporated. When the cage is dropped or handled roughly, the pinion gear may come off. In addition, do not cut off the cage as doing so may cause pinion gear coming off and breakage of gear joint section.

Way of the CRWUG series has a rack incorporated. In operation, take note that the rack may come off when the end screw is removed.

For the CRWU series, the cage may be deviated from the right position due to offset load or irregular and high-velocity motion, etc. Fully stroke it once in certain operating time or certain number of reciprocating motion to correct the cage position.

2 Preload re-adjustment

Preload amount of the CRWUG series and CRWU series is adjusted to zero or slight preload state, so they may be used as they are.

Preload amount of the CRWUG series, CRWU, and CRWU...R may be re-adjusted by following the procedure below.

Preload adjustment is started from the preload adjusting screw at the center of way length and then both ends in turn, with fixing screws of the preload adjusting side way temporarily fixed.

While measuring the clearance on the table sides, tighten the preload adjusting screws subsequently until deflection of the dial gauge stops. Measure the tightening torque for preload adjusting screws at this point.

When adjusting preload adjusting screw near either end, stroke the table softly and check that the cylindrical roller is on the preload adjusting screw section.

After the above procedure, the clearance becomes zero or in slight preload state, but preload is still not adjusted evenly. With the same procedure again, re-adjust all the preload adjusting screws evenly to the torque previously measured.

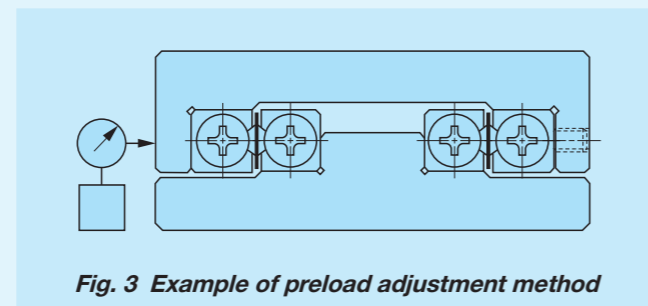

Fig. 3 Example of preload adjustment method

3 Operating temperature

As synthetic resin components are used for the CRWUG series, the maximum operating temperature is 120°C, while it should be lower than 100°C for continuous use. When it exceeds 100°C, contact **IKO**.

As synthetic resin components are not used for the CRWU series, it may be used at high temperature. However, when it exceeds 100°C, contact **IKO**.

4 Maximum velocity

Operating velocity should not exceed 30 m/min during operation.

5 Tightening torque for fixing screw

Table 3 shows typical tightening torque for mounting CRWUG Series and CRWU Series. When vibration and shock are large or moment load is applied, it is recommended to fix by using the torque 1.3 times larger than that indicated in the table. In addition, when high running accuracy is required with no vibration and shock, it may be fixed by using torque smaller than that indicated in the table, however, it is recommended to use adhesive agent to fasten the screw, or to use stop bolts.

Table 3 Tightening torque for fixing screw

Bolt size	Tightening torque N · m
M 2 ×0.4	0.40
M 2.5×0.45	0.80
M 3 ×0.5	1.4
M 4 ×0.7	3.2
M 5 ×0.8	6.4
M 6 ×1	10.9
M 8 ×1.25	26.1

6 Dowel pin hole of CRWU...R

A dowel pin hole is machined on the center way of the CRWU...R. When a dowel pin is used, machine a hole on the mounting surface of the machine after mounting of the center way.

Refer to the dimension table for diameter and its tolerances of dowel pin hole of the center way.

7 Mounting part dimensions of CRWU...R

Not to allow the table to interfere with the mounting surface, it is necessary to set mounting surface height referring to the dimensions H_1 and H in the dimension table.

Example bed mounting dimensions are indicated in Table 4.

Table 4 Example of mounting dimensions of CRWU...R bed

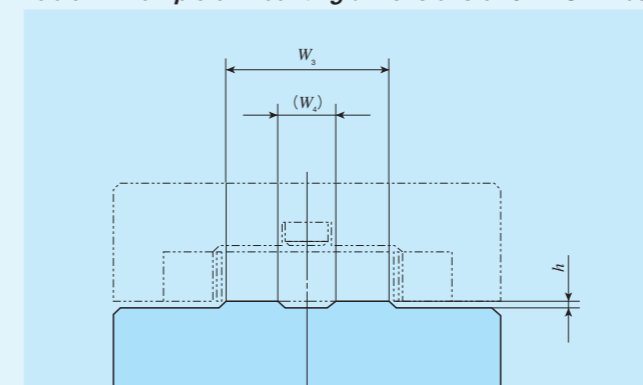

Identification number	h (minimum)	W_3	W_4
CRWU 30 ...R	0.5	13	—
CRWU 40-35R	0.5	18	—
CRWU 40 ...R		13	
CRWU 60 ...R	0.5	26.5	—
CRWU 80 ...R	0.5	38	16
CRWU100 ...R	0.5	42	14
CRWU145 ...R	1.0	68.5	28.5

IKO Crossed Roller Way Unit

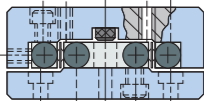
Shape					
Size	30	40	60	80	100 145

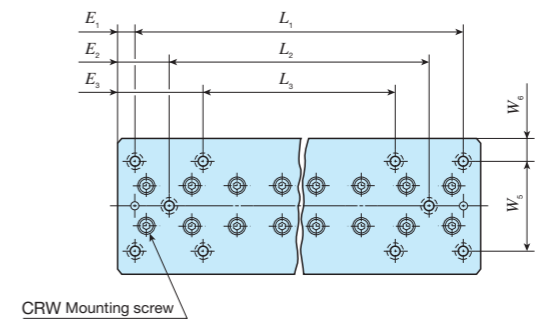
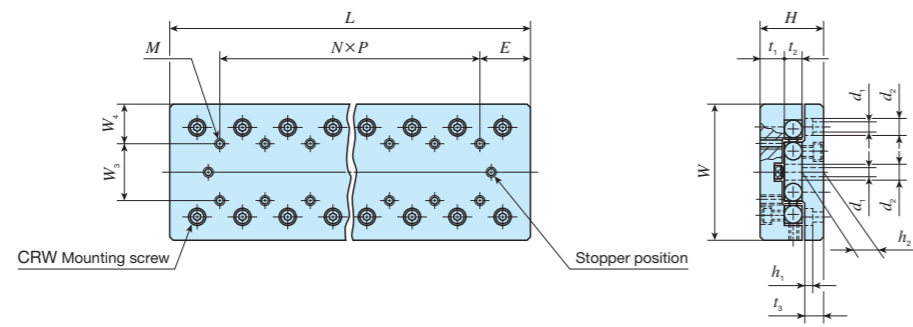

Identification number	Mass (Ref.) kg	Nominal dimensions and tolerances mm								Table mounting dimensions mm					Bed mounting dimensions mm										Basic dynamic load rating C N	Basic static load rating C ₀ N	Allowable load F N	Static moment rating T ₀ N·m					
		W	Dim. W tolerance	H	Dim. H tolerance	L	t ₁	t ₂	t ₃	Maximum stroke length	W ₃	W ₄	N x P	E	M	W ₅	W ₆	L ₁	E ₁	L ₂	E ₂	L ₃	E ₃	d ₁					d ₂	h ₁	h ₂		
CRWU 30- 25	0.09	30	±0.1	17	±0.1	25	7	4	5.5	12	10	10	-	12.5	M2	22	4	18	3.5	-	-	-	-	2.55	4.1	2.5	6	380	478	159	3.2		
CRWU 30- 35	0.13					35				18			1 x 10					28										-	-	525	717	239	4.8
CRWU 30- 45	0.17					45				25			2 x 10					38										-	-	659	956	319	6.5
CRWU 30- 55	0.20					55				32			3 x 10					48										28	13.5	786	1 200	398	8.1
CRWU 30- 65	0.24					65				40			4 x 10					58										38		906	1 430	478	9.7
CRWU 30- 75	0.28					75				45			5 x 10					68										45		1 020	1 670	558	11.3
CRWU 30- 85	0.32					85				50			6 x 10					78										58		1 140	1 910	638	12.9
CRWU 40- 35	0.21	40	±0.1	21	±0.1	35	7	8	5.5	18	15	12.5	-	17.5	M3	30	5	25	5	-	-	-	-	3.5	6	3.2	6	896		1 180	392	10.6	
CRWU 40- 50	0.30					50				30			1 x 15					40										-	-	2 710	3 660	1 220	26.5
CRWU 40- 65	0.37					65				40			2 x 15					55										-	-	2 710	3 660	1 220	26.5
CRWU 40- 80	0.48					80				50			3 x 15					70										40	20	4 050	6 090	2 030	44.2
CRWU 40- 95	0.54					95				60			4 x 15					85										55		3 400	4 880	1 630	35.3
CRWU 40-110	0.65					110				70			5 x 15					100										70		4 680	7 310	2 440	53.0
CRWU 40-125	0.72					125				80			6 x 15					115										85		4 680	7 310	2 440	53.0
CRWU 60- 55	0.68	60	±0.1	28	±0.1	55	10.5	8	9	30	25	17.5	-	27.5	M4	40	10	35	10	-	-	-	-	4.5	7.5	4.5	9.5	2 710		3 660	1 220	51.2	
CRWU 60- 80	1.0					80				45			1 x 25					60										-	-	4 050	6 090	2 030	85.3
CRWU 60-105	1.3					105				60			2 x 25					85										-	-	5 270	8 530	2 840	119
CRWU 60-130	1.6					130				75			3 x 25					110										85	35	5 860	9 750	3 250	137
CRWU 60-155	1.9					155				90			4 x 25					135										110		6 970	12 200	4 060	171
CRWU 60-180	2.2					180				105			5 x 25					160										135		8 040	14 600	4 880	205
CRWU 60-205	2.5					205				130			6 x 25					185										135		8 550	15 800	5 280	222

CRW(G)(...H)
CRWU(G)

IKO Crossed Roller Way Unit

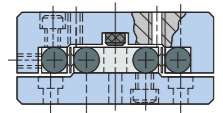
Shape						
Size	30	40	60	80	100	145

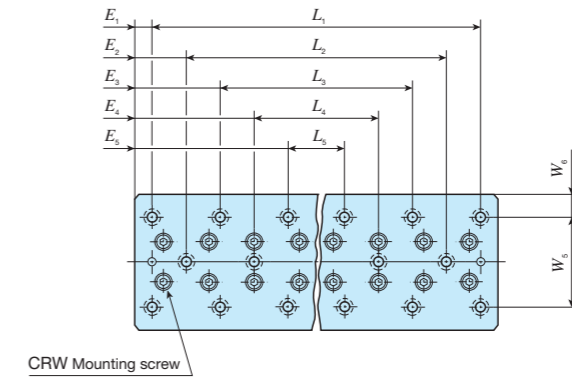
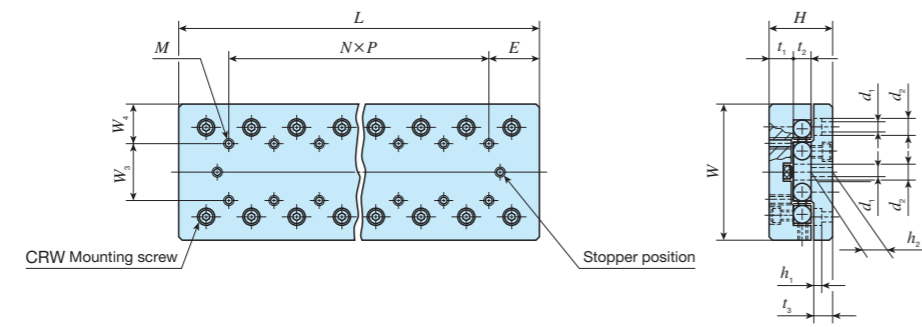

Identification number	Mass (Ref.) kg	Nominal dimensions and tolerances mm								Table mounting dimensions mm						Bed mounting dimensions mm												Basic dynamic load rating C N	Basic static load rating C ₀ N	Allowable load F N	Static moment rating T ₀ N·m					
		W	Dim. W tolerance	H	Dim. H tolerance	L	t ₁	t ₂	t ₃	Maximum stroke length	W ₃	W ₄	N x P	E	M	W ₅	W ₆	L ₁	E ₁	L ₂	E ₂	L ₃	E ₃	L ₄	E ₄	L ₅	E ₅					d ₁	d ₂	h ₁	h ₂	
		CRWU 80-85	1.8					85				50								65	10															
CRWU 80-125	2.6					125				75		1 x 40					80																9 130	14 100	4 700	282
CRWU 80-165	3.4					165				105		2 x 40					120																10 300	16 500	5 480	329
CRWU 80-205	4.2	80	±0.1	35	±0.1	205	13	11	10.5	135	40	3 x 40	42.5	M5	60	10	160	22.5				80					5.5	9.5	6	11			12 500	21 200	7 050	423
CRWU 80-245	5.1					245				155		4 x 40					200																14 700	25 900	8 620	517
CRWU 80-285	5.9					285				185		5 x 40					240																16 700	30 600	10 200	611
CRWU 80-325	6.7					325				215		6 x 40					280									120	102.5						18 700	35 300	11 800	705
CRWU 100-110*	3.6					110				60							90																13 900	18 500	6 150	415
CRWU 100-160*	5.2					160				95		1 x 50					140																16 600	23 100	7 690	519
CRWU 100-210*	6.9					210				130		2 x 50					190	90															21 600	32 300	10 800	727
CRWU 100-260*	8.5	100	±0.15	45	±0.1	260	16	15	13	165	50	3 x 50	55	M6	60	20	240	10									7	11	6.5	14			26 300	41 500	13 800	934
CRWU 100-310*	10.2					310				200		4 x 50					290																30 800	50 700	16 900	1 140
CRWU 100-360*	11.8					360				235		5 x 50					340																35 100	60 000	20 000	1 350
CRWU 100-410*	13.5					410				265		6 x 50					390																37 200	64 600	21 500	1 450
CRWU 145-210*	13.2					210				130							100																39 400	52 800	17 600	1 900
CRWU 145-310*	19.6					310				180		1 x 100					200																61 200	92 300	30 800	3 320
CRWU 145-410*	25.9					410				350		2 x 100					300	100															67 900	106 000	35 200	3 800
CRWU 145-510*	32.2	145	±0.2	60	±0.1	510	21	22	16	450	85	3 x 100	105	M8	90	27.5	400	55									9	14	8.5	17.5			74 400	119 000	39 600	4 270
CRWU 145-610*	38.6					610				550		4 x 100					500																87 100	145 000	48 400	5 220
CRWU 145-710*	45.0					710				650		5 x 100					600																99 200	172 000	57 200	6 170
CRWU 145-810*	51.3					810				750		6 x 100					700							100	355								111 000	198 000	66 000	7 120

Remark: The identification numbers with * are our semi-standard items.

CRW(G)(...H)
CRWU(G)

IKO Crossed Roller Way Unit

Shape	CRWU...R					
Size	30	40	60	80	100	145

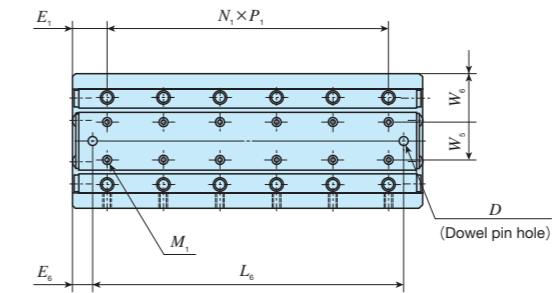
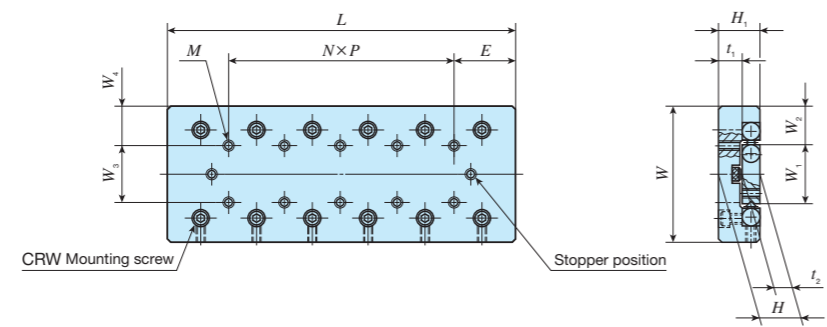

Identification number	Mass (Ref.) kg	Nominal dimensions and tolerances mm						Table mounting dimensions mm							Center way mounting dimensions and tolerances mm											Basic dynamic load rating C N	Basic static load rating C ₀ N	Allowable load F N	Static moment rating T ₀ N·m											
		W	Dim. W tolerance	H	Dim. H tolerance	L	Maximum stroke length	W ₃	W ₄	N×P	E	M	H ₁	t ₁	W ₅	W ₆	N ₁ ×P ₁	E ₁	M ₁	D	Dim. D tolerance	L ₆	E ₆	W ₁	W ₂					t ₂										
CRWU 30- 25R	0.06	30	±0.1	11	±0.1	25	12	10	10	—	12.5	M2	11	7	—	15	1×10	7.5	M2	—	—	—	—	12.8	8.6	4	380	478	159	3.2										
CRWU 30- 35R	0.08					35	18			1×10							2×10										4×10	5×10	6×10	7×10	30	40	50	60	786	1 200	398	8.1		
CRWU 30- 45R	0.11					45	25			2×10							3×10										4×10	5×10	6×10	7×10	2	+0.020 0	30	40	50	60	786	1 200	398	8.1
CRWU 30- 55R	0.13					55	32			3×10							4×10										5×10	6×10	7×10	2	+0.020 0	30	40	50	60	906	1 430	478	9.7	
CRWU 30- 65R	0.16					65	40			4×10							5×10										6×10	7×10	2	+0.020 0	30	40	50	60	1 020	1 670	558	11.3		
CRWU 30- 75R	0.18					75	45			5×10							6×10										7×10	2	+0.020 0	30	40	50	60	1 140	1 910	638	12.9			
CRWU 30- 85R	0.21					85	50			6×10							7×10										2	+0.020 0	30	40	50	60	1 140	1 910	638	12.9				
CRWU 40- 35R	0.13					40	±0.1			14							±0.1										35	18	15	12.5	—	17.5	M3	14	8	—	20	1×15	10	M3
CRWU 40- 50R	0.21	50	30	1×15	2×15			4×15	5×15	6×15	45	17.5	25	32.5	2 710	3 660		1 220	26.5																					
CRWU 40- 65R	0.26	65	40	2×15	3×15			4×15	5×15	6×15	45	17.5	25	32.5	2 710	3 660		1 220	26.5																					
CRWU 40- 80R	0.34	80	50	3×15	4×15			5×15	6×15	45	17.5	25	32.5	4 050	6 090	2 030		44.2																						
CRWU 40- 95R	0.38	95	60	4×15	5×15			6×15	45	17.5	25	32.5	4 050	6 090	2 030	44.2																								
CRWU 40-110R	0.46	110	70	5×15	6×15			45	17.5	25	32.5	4 050	6 090	2 030	44.2																									
CRWU 40-125R	0.50	125	80	6×15	45			17.5	25	32.5	4 050	6 090	2 030	44.2																										
CRWU 60- 55R	0.44	60	±0.1	18.5	±0.1			55	30	25	17.5	—	27.5	M4	18.5	10.5		—	17	1×25	15	M4	4	+0.020 0	10	26.6	16.7	8			2 710			3 660	1 220			51.2		
CRWU 60- 80R	0.66					80	45	1×25	2×25			4×25					5×25			6×25									7×25	60	85	110	135	160	185	4 050	6 090	2 030	85.3	
CRWU 60-105R	0.85					105	60	2×25	3×25			4×25					5×25			6×25									7×25	60	85	110	135	160	185	5 270	8 530	2 840	119	
CRWU 60-130R	1.1					130	75	3×25	4×25			5×25					6×25			7×25									60	85	110	135	160	185	5 860	9 750	3 250	137		
CRWU 60-155R	1.3					155	90	4×25	5×25			6×25					7×25			60									85	110	135	160	185	6 970	12 200	4 060	171			
CRWU 60-180R	1.5					180	105	5×25	6×25			7×25					60			85									110	135	160	185	8 040	14 600	4 880	205				
CRWU 60-205R	1.7					205	130	6×25	7×25			60					85			110									135	160	185	8 550	15 800	5 280	222					

CRW(G)(...H)
CRW(G)

IKO Crossed Roller Way Unit

Shape	CRWU...R					
Size	30	40	60	80	100	145

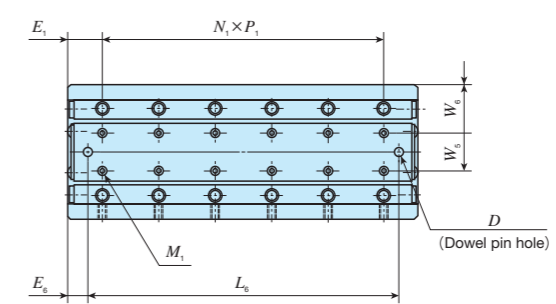
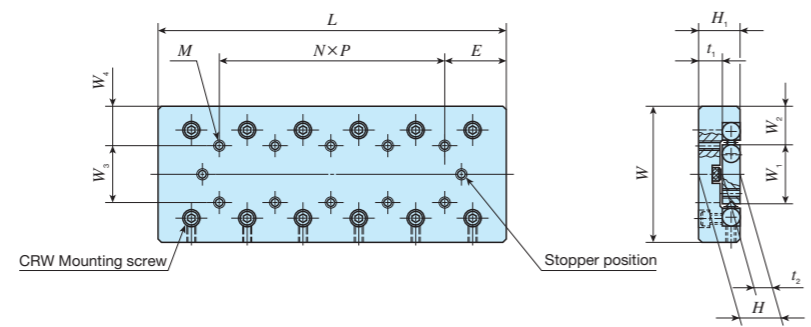

Identification number	Mass (Ref.) kg	Nominal dimensions and tolerances mm					Table mounting dimensions mm							Center way mounting dimensions and tolerances mm										Basic dynamic load rating C N	Basic static load rating C ₀ N	Allowable load F N	Static moment rating T ₀ N·m			
		W	Dim. W tolerance	H	Dim. H tolerance	L	Maximum stroke length	W ₃	W ₄	N×P	E	M	H ₁	t ₁	W ₅	W ₆	N ₁ ×P ₁	E ₁	M ₁	D	Dim. D tolerance	L ₀	E ₀					W ₁	W ₂	t ₂
CRWU 80- 85R	1.2	80	±0.1	24	±0.1	85	50	40	20	—	42.5	M5	24	13	27	26.5	1×40	22.5	M5	5	+0.020 0	55	15	38	21	11	6 640	9 400	3 130	188
CRWU 80-125R	1.8					125	75			1×40							95					9 130					14 100	4 700	282	
CRWU 80-165R	2.3					165	105			2×40							135					10 300					16 500	5 480	329	
CRWU 80-205R	2.9					205	135			3×40							175					12 500					21 200	7 050	423	
CRWU 80-245R	3.5					245	155			4×40							215					14 700					25 900	8 620	517	
CRWU 80-285R	4.0					285	185			5×40							255					16 700					30 600	10 200	611	
CRWU 80-325R	4.6					325	215			6×40							295					18 700					35 300	11 800	705	
CRWU 100-110R*	2.4					100	±0.15			31							±0.1					110					60	50	25	—
CRWU 100-160R*	3.6	160	95	1×50	120			16 600	23 100		7 690	519																		
CRWU 100-210R*	4.7	210	130	2×50	170			21 600	32 300		10 800	727																		
CRWU 100-260R*	5.9	260	165	3×50	220			26 300	41 500		13 800	934																		
CRWU 100-310R*	7.0	310	200	4×50	270			30 800	50 700		16 900	1 140																		
CRWU 100-360R*	8.1	360	235	5×50	320			35 100	60 000		20 000	1 350																		
CRWU 100-410R*	9.3	410	265	6×50	370			37 200	64 600		21 500	1 450																		
CRWU 145-210R*	9.4	145	±0.2	42.5	±0.1			210	130		85	30	—	105	M8	43		21	46	49.5	1×100	55	M8	5	+0.020 0	150	30			68.4
CRWU 145-310R*	13.9					310	180	1×100	250	61 200			92 300				30 800				3 320									
CRWU 145-410R*	18.4					410	350	2×100	350	67 900			106 000				35 200				3 800									
CRWU 145-510R*	23.0					510	450	3×100	450	74 400			119 000				39 600				4 270									
CRWU 145-610R*	27.5					610	550	4×100	550	87 100			145 000				48 400				5 220									
CRWU 145-710R*	32.0					710	650	5×100	650	99 200			172 000				57 200				6 170									
CRWU 145-810R*	36.6					810	750	6×100	750	111 000			198 000				66 000				7 120									

Remark: The identification numbers with * are our semi-standard items.

CRW(G)(...H)
CRW(G)

IKO Crossed Roller Way Unit

Shape	CRWU...RS		
Size	20	30	40



Identification number	Mass (Ref.) kg	Nominal dimensions and tolerances mm						Table mounting dimensions mm						Center way mounting dimensions mm						Basic dynamic load rating C N	Basic static load rating C ₀ N	Allowable load F N	Static moment rating T ₀ N · m	
		W	Dim. W tolerance	H	Dim. H tolerance	L	Maximum stroke length	W ₃	W ₄	N × P	E	M	H ₁	t ₁	W ₁	W ₂	N ₁ × P ₁	E ₁	M ₁					t ₂
CRWU 20- 25RS	0.03	20	±0.1	8	±0.1	25	12	14	3	1 × 18	3.5	M2.5	7.5	3.5	7	6.5	2 × 7.5	5	M2.5	4	380	478	159	1.8
CRWU 20- 35RS	0.05					35	18			1 × 28							2 × 10							
CRWU 20- 45RS	0.06					45	25			1 × 20	3 × 10						7.5	659			956	319	3.7	
CRWU 20- 55RS	0.07					55	32			1 × 30	4 × 10						786	1 200			398	4.6		
CRWU 30- 65RS	0.20	30	±0.1	12	±0.1	65	40	22	4	1 × 30	17.5	M3	11.5	5.5	12	9	3 × 15	10	M3	6	1 850	2 940	979	19.1
CRWU 30- 80RS	0.24					80	50			1 × 45							4 × 15							
CRWU 30- 95RS	0.29					95	60			2 × 30							5 × 15				2 410	4 110	1 370	26.7
CRWU 40-105RS	0.58	40	±0.1	16	±0.1	105	60	30	5	1 × 50	27.5	M4	15.5	7.5	16	12	3 × 25	15	M4	8	4 680	7 310	2 440	63.6
CRWU 40-130RS	0.72					130	75			1 × 75							4 × 25				5 860	9 750	3 250	84.8
CRWU 40-155RS	0.85					155	90			2 × 50							5 × 25				6 970	12 200	4 060	106

CRW(G)(...H)
CRWU(G)

Linear Slide Unit

High Rigidity Precision Linear Slide Unit
Precision Linear Slide Unit
Linear Slide Unit

BWU · BSP(G)
BSU...A



High Rigidity Precision Linear Slide Unit

BWU



Points

● Simple limited linear motion guide structure

Small and simple limited stroke type structure incorporated with balls and retainer between integrated table and bed. With two-row four-point contact structure, stable accuracy and rigidity can be achieved even in applications where fluctuating load and complex load are applied.

● High accuracy

Simultaneous grinding process of two-row track grooves is applied to table and bed, which provides small processing errors and realizes linear motion of high accuracy.

● Smooth operations

As each component is finished with accuracy without recirculation resistance of the balls, light and smooth operations are obtained.

● Stainless steel selections for excellent corrosion resistance

Stainless steel highly resistant to corrosion is used for all steel components, so that they are suitable for applications where rust prevention oil is not preferred, such as in a cleanroom environment.

Identification Number and Specification

Example of an identification number

The specification of BWU series is indicated by the identification number. Indicate the identification number, consisting of a model code and dimensions for each specification to apply.

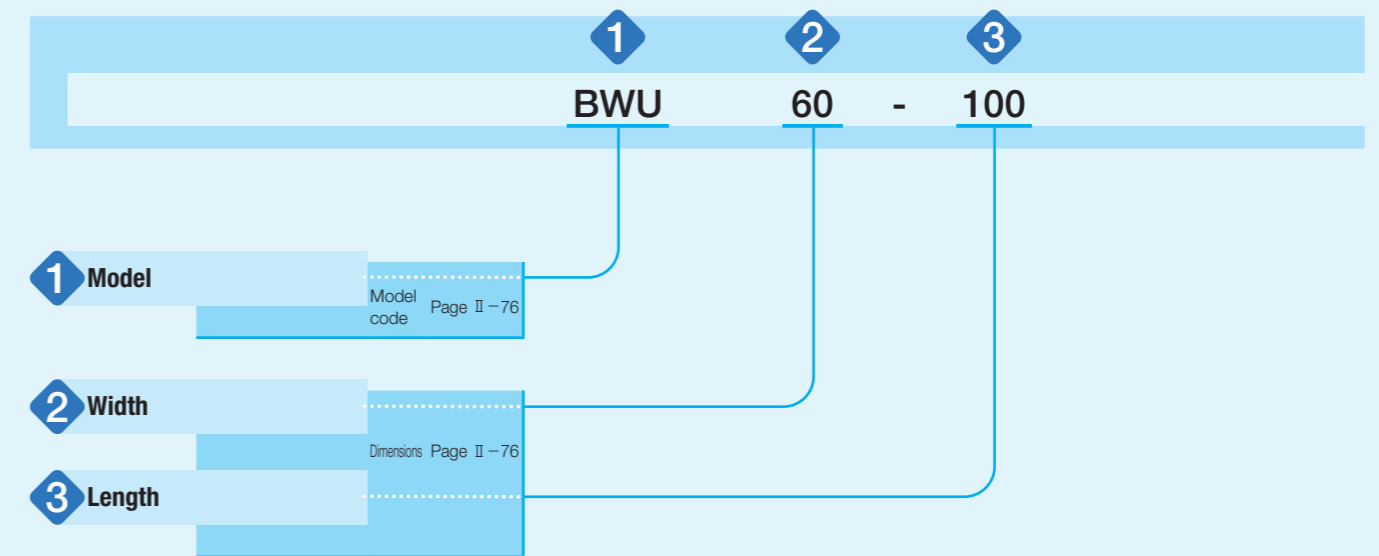

Identification Number and Specification

1 Model	High Rigidity Precision Linear Slide Unit (BWU series)	: BWU
	For applicable models, width and length, see Table 1.	
2 Width	6, 8, 10, 12, 17, 25, 30, 40, 60	Indicate the table width in mm. For applicable models, width and length, see Table 1.
3 Length		Indicate the table length in mm. For applicable models, width and length, see Table 1.

Table 1 Width and length of BWU series

unit: mm

Shape	Model	Width	Length												
			10	15	20	25	30	40	45	60	75	80	90	100	120
	BWU	6	○	-	○	-	○	-	-	-	-	-	-	-	-
		8	○	-	○	-	○	-	-	-	-	-	-	-	-
		10	-	○	-	○	-	○	-	-	-	-	-	-	-
		12	-	-	○	-	○	-	○	-	-	-	-	-	-
		17	-	-	○	-	○	-	○	-	-	-	-	-	-
		25	-	-	-	-	○	-	○	○	○	-	-	-	-
		30	-	-	-	-	○	-	○	○	○	-	○	-	-
		40	-	-	-	-	-	○	-	○	-	○	-	○	-
60	-	-	-	-	-	-	-	-	○	-	○	-	○	○	

Allowable Load

Allowable load refers to load of smooth rolling motion on contact surface to which maximum contact stress is applied and the sum of whose elastic deformation of rolling elements and raceway is small.

Therefore, use applied load within the allowable load range if very smooth rolling motion and high accuracy are required.

Load Direction and Load Rating

The BWU series must be used with its load rating corrected in accordance to the load direction. The basic dynamic load rating and basic static load rating shown in the dimension table should be corrected to values in Table 2.

Table 2 Load ratings corrected for load direction

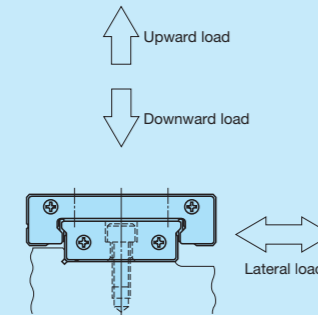

Load rating and load direction	Basic dynamic load rating			Basic static load rating		
	Load direction			Load direction		
Width	Downward	Upward	Lateral	Downward	Upward	Lateral
6~60	C	C	1.19C	C_0	C_0	1.19 C_0

Accuracy

Accuracy of the BWU series is indicated in Table 3 and Table 4.

Table 3 Accuracy

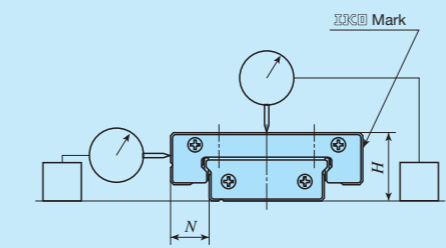

unit: mm

Item	Tolerance and allowance
Dim. H tolerance	± 0.040
Dim. N tolerance	± 0.050
Parallelism at the table center	See Table 4
Parallelism on the table side	See Table 4

Table 4 Running accuracy

unit: μm

Nominal length L mm		Parallelism at the table center ⁽¹⁾	Parallelism on the table side ⁽²⁾
Over	Incl.		
—	50	4	6
50	80	5	8
80	120	6	9

Notes ⁽¹⁾ Parallelism at the center of the table represents parallelism of height when the table is stroked.

⁽²⁾ Parallelism at the side of the table represents parallelism of the side (the opposite side of  mark) when the table is stroked.

Preload

Preload for the BWU series is adjusted to proper preload state.

Lubrication

Grease is not pre-packed in the BWU series, so please perform adequate lubrication as needed.

Upon delivery, anti-rust oil is applied. Therefore, perform cleaning with clean solution before mounting and apply high-quality lubrication oil or grease before use. For grease lubrication, use of high-quality lithium-soap base grease is recommended.

Since no grease nipple or oil hole is provided, apply grease directly to the raceway part of the bed when supplying the grease.

Dust Protection

No dust protection seal is provided for BWU series. For applications in other than clean environment, cover the entire unit with a protective case, etc. to prevent harmful foreign substances such as dust and particles from outside from entering.

Precaution for Use

1 Handling

When high running accuracy is required, set the load point at the center of the table (or bed) and use with sufficient stroke length.

For the BWU series, the retainer may be deviated from the right position due to offset load or irregular and high-velocity motion, etc. Fully stroke it once in certain operating time or certain number of reciprocating motion to correct the retainer position.

Since there is no built-in mechanical stopper to regulate linear motion to regulate linear motion, install a stopper mechanism in proximity if risk of overstroke exists.

The fixing thread depth of mounting screws for table must not exceed the maximum fixing thread depth indicated in the table of dimensions. Since the mounting screw hole for the table is penetrated, the bed or retainer will be pushed by the screw if the fixing thread depth is too deep, and the running accuracy and life may be adversely affected.

2 Operating temperature

As synthetic resin components are not used for the BWU series, it may be used at high temperature. However, when it exceeds 100°C, contact **IKO**.

3 Maximum velocity

Operating velocity should not exceed 30 m/min during operation.

Precaution for Mounting

1 Reference mounting surface

Reference mounting surface of the BWU series is the opposite side of the **IKO** Mark. (See Fig. 1)

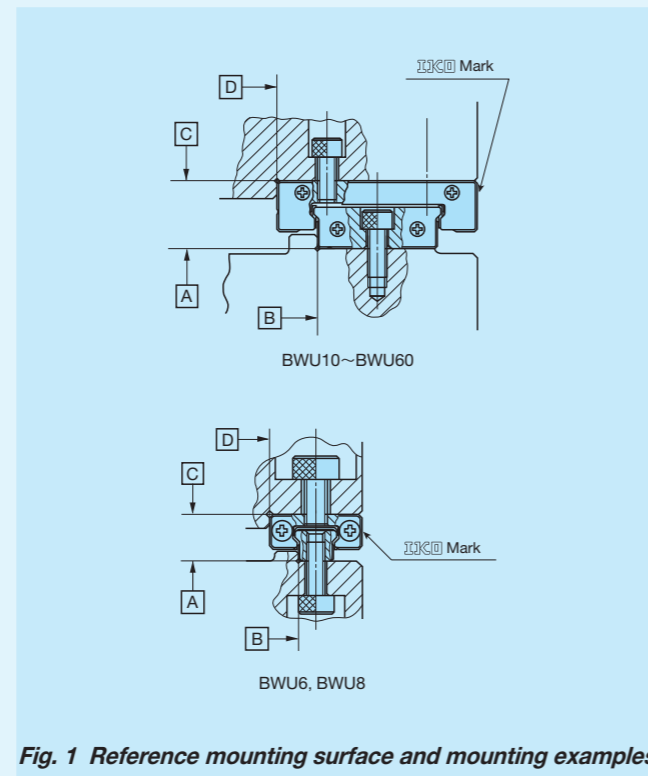

Fig. 1 Reference mounting surface and mounting examples

2 Typical mounting structure

As indicated in Fig.1, reference mounting surfaces B and D, and mounting surfaces A and C are precisely ground. Therefore, by machining the reference mounting surface of the mating member and the mounting surface, such as machine or device, to high accuracy and mounting them properly, stable linear motion with high accuracy is realized. For the opposite corner of the mating reference mounting, it is recommended to have relieved fillet as indicated in the illustration in Table 5. The value indicated in Table 5 is recommended for the shoulder height on the mating side.

Table 5 Shoulder height

Width	Shoulder height of the table side h_1	Shoulder height of the bed side h_2
6	1	0.5
8	1.2	0.8
10	1.2	0.8
12	1.5	0.8
17	2.5	1.2
25	2.5	1.5
30	3	2
40	3	2.5
60	4	2.5

unit: mm

3 When lateral load is the primary load

As indicated in Fig. 2, firmly fix the sides of the table and bed with pressure plates.

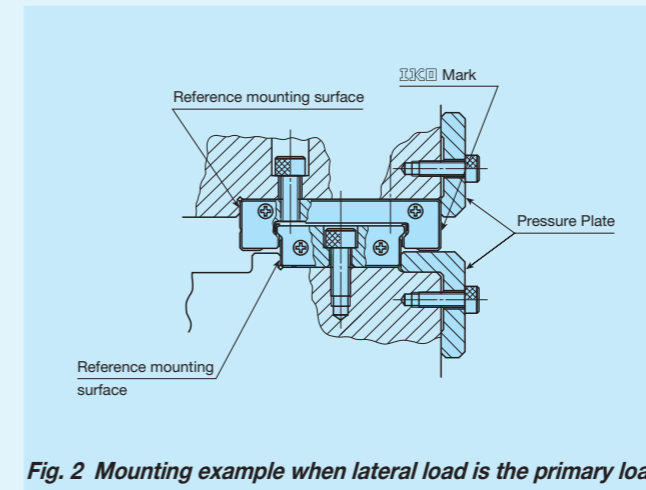

Fig. 2 Mounting example when lateral load is the primary load

4 Tightening torque for fixing screw

Typical tightening torque for mounting of the BWU series to the steel mating member material is indicated in Table 6. If the mating member material is cast iron or aluminum alloy, reduce the tightening torque depending on the strength characteristics of the mating member material.

Table 6 Tightening torque for fixing screw

Bolt size	Tightening torque N · m
M1 ×0.25	0.04
M1.4×0.3	0.10
M1.6×0.35	0.15
M2 ×0.4	0.31
M3 ×0.5	1.1
M4 ×0.7	2.5

Remark: The tightening torque is calculated based on property division A2-70 of stainless steel hexagon socket head bolt.

Precision Linear Slide Unit

Limited linear motion type

BSP

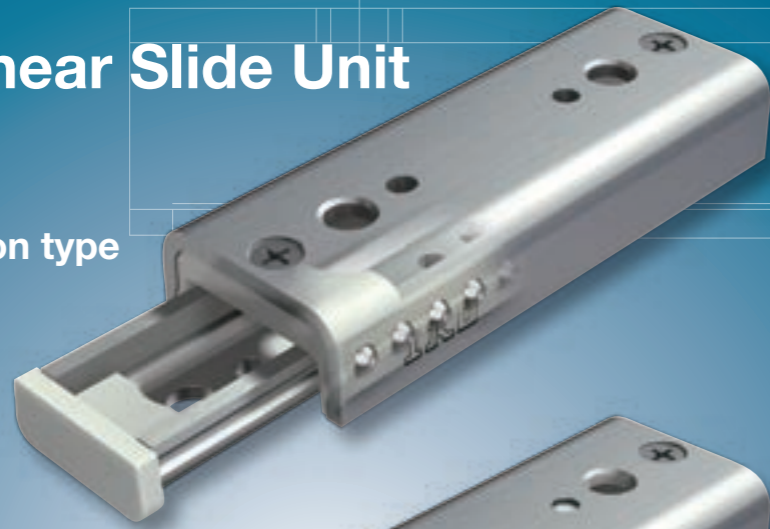

Built-in rack & pinion type

BSPG

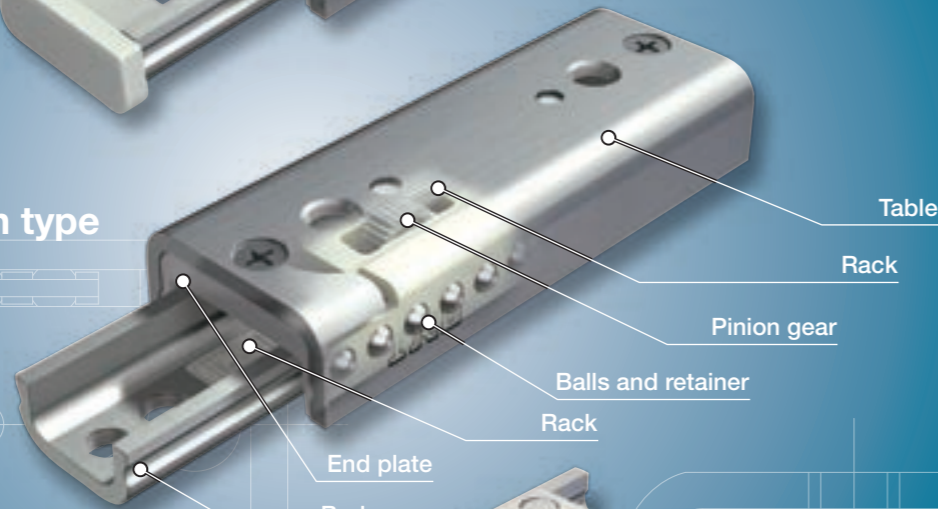

Endless linear motion type

BSR

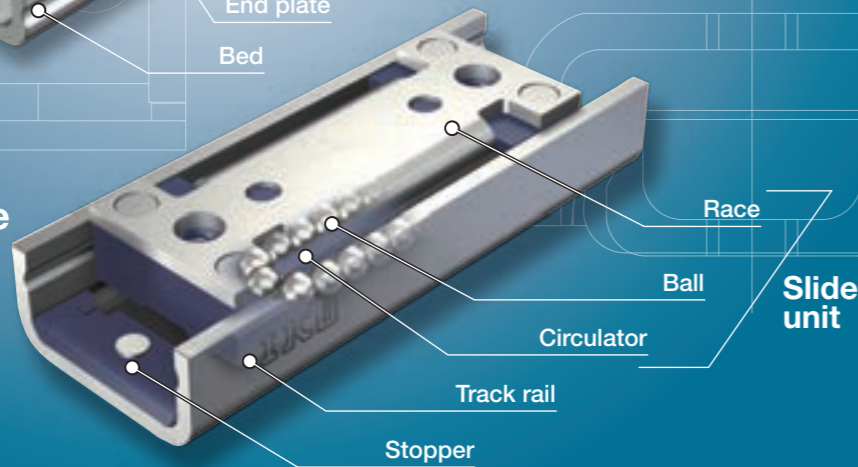

Identification Number and Specification

Example of an identification number

The specifications of BSP, BSPG and BSR are indicated by the identification number. Indicate the identification number, consisting of a model code, dimensions, a material code, and a clearance code for each specification to apply.

	1	2	3	4	5
	BSP	15	50	SL	T ₁
	BSPG	12	35	SL	T ₁
	BSR	20	60	SL	T ₁

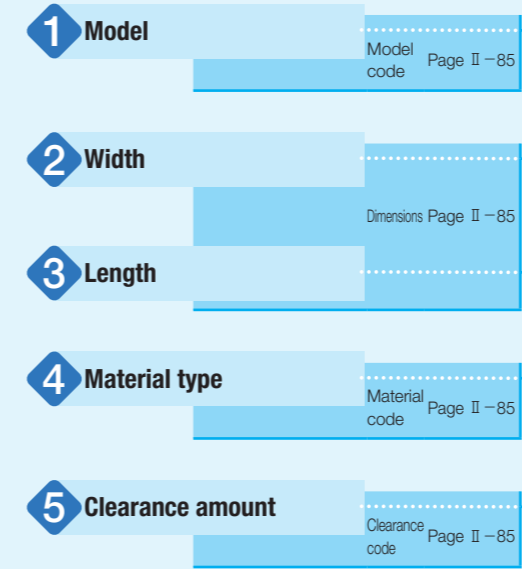

BWU · BSP(G)
BSU...A

Points

1 Light weight and compact

Weight is saved by precise forming of stainless steel plate to U shape and integration of the way and mounting surface, and downsizing was realized by functional allocation of parts.

2 Stable performance

With simple two-row four-point contact structure, motion accuracy with stable load carrying capacity and high motion accuracy can be achieved for load in every direction.

3 Quiet and smooth operations

The excellent retaining and guiding mechanism of the ball and precisely-finished raceway realizes very quiet and smooth operations. High response characteristics and positioning accuracy are obtained for micro-feeding operation as well.

4 High safety

Since non-combustible or self-extinguishing materials are used for all synthetic resin components, they may be used for wide range of applications including household office automation equipment that requires incombustibility.

5 Stainless steel selections for excellent corrosion resistance

Stainless steel highly resistant to corrosion is used for all steel components, so that they are suitable for applications where rust prevention oil is not preferred, such as in a cleanroom environment.

Identification Number and Specification

1 Model	Precision Linear Slide Unit	Limited linear motion type	: BSP
		Built-in rack & pinion type	: BSPG
		Endless linear motion type	: BSR
For applicable models and width, see Table 1.			

2 Width	7, 10, 12, 15, 20, 25	Indicate the width in mm.
	For applicable models and width, see Table 1.	

Table 1 Models and width

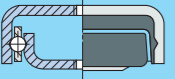
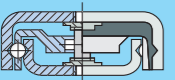
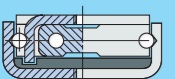
Shape	Model	Characteristics	Width					
			7	10	12	15	20	25
Limited linear motion type 	BSP	Retainer made of special synthetic resin is used to prevent interference noise from contact of balls. This type performs very smooth and light limited linear motion without stick-slip.	○	○	—	○	○	○
Built-in rack & pinion type 	BSPG	A pinion gear assembled in the retainer integrated with two-row ball raceway is engaged with the racks fixed to the table and bed to prevent creeping of retainer position. Like BSP, this type also performs smooth linear motion.	—	—	○	○	○	○
Endless linear motion type 	BSR	The ball circulation structure made of special synthetic resin realizes quiet and smooth endless linear motion according to the length of a track rail.	—	—	○	○	○	○

3 Length		Indicate the length in mm.

4 Material type	Stainless steel made	: SL	Stainless steel (SL) can be specified only for the material type.

5 Clearance amount	Standard	: No symbol	For details of clearance amount, see Table 2.
	T ₁ Clearance	: T ₁	Typically, apply the standard clearance for use in small frictional resistance and the clearance adjusted to the clearance code T ₁ for applications requiring high linear motion accuracy.

Table 2 Clearance of raceways unit: μm

Type and code	Clearance of raceways
Standard (no symbol)	0 ~ +4
T ₁	-4 ~ 0

Accuracy

Table 3 Running accuracy for BSP and BSPG

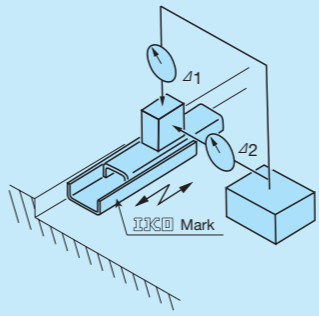

unit: μm

Stroke length mm		Parallelism at the bed center against the table mounting surface Δ ₁	Parallelism at the bed center against the table reference mounting surface Δ ₂
Over	Incl.		
—	18	3	6
18	30	4	8
30	50	5	10
50	80	6	12

Table 4 Running accuracy for BSR

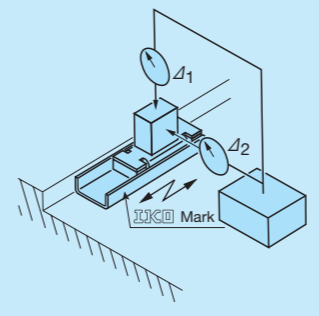

unit: μm

Stroke length mm		Parallelism at the slide unit center against the track rail mounting surface Δ ₁	Parallelism at the slide unit center against the track rail reference mounting surface Δ ₂
Over	Incl.		
—	18	3	6
18	30	4	8
30	50	5	10
50	80	6	12

Lubrication

Grease is not pre-packed in the BSP and BSR, so please perform adequate lubrication as needed.

Upon delivery, anti-rust oil is applied. Therefore, perform cleaning with clean solution before mounting, apply high-quality lubrication oil or grease to the raceway, and conduct shakedown before use.

The BSPG is packed with special grease applied to the raceway and rack and pinion. In general applications, keep cleanliness and mount it as it is.

Precaution for Use

1 Applied load

For use with stable and high running accuracy, it is recommended to use applied load around 20% or lower of the basic static load rating.

2 Handling

When high running accuracy is required for BSP and BSPG, set the load point at the center of the table (or bed) and use with sufficient stroke length.

For the BSP, the retainer may be deviated from the right position due to offset load or irregular and high-velocity motion, etc. Fully stroke it once in certain operating time or certain number of reciprocating motion to correct the retainer position. If it is difficult to correct the retainer position, use BSPG or BSR.

Since BSP, BSPG and BSR have no built-in mechanical stopper to regulate linear motion, install a stopper mechanism in proximity if risk of overstroke exists.

3 Operating temperature

The maximum operating temperature is 120°C and temperature up to 100°C is allowed for continuous operation. However, when it exceeds 100°C, contact **IKO**.

4 Maximum velocity

Operating velocity should not exceed 30 m/min during operation.

Precaution for Mounting

1 Reference mounting surface

Reference mounting surface is the opposite side of the **IKO** mark.

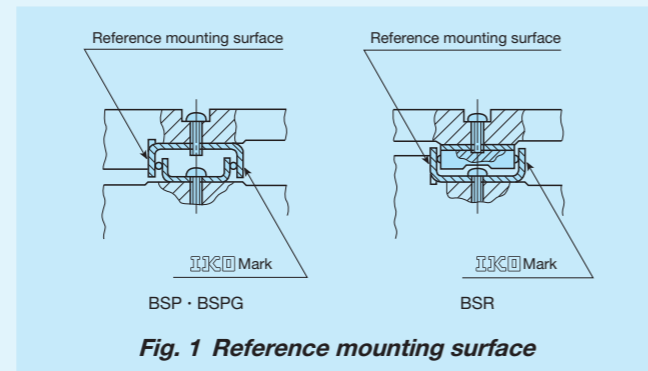

2 Typical mounting structure

The mating surface to mount BSP, BSPG and BSR should be finished to high accuracy as much as possible so as not to affect the motion accuracy.

For the opposite corner of the mating reference mounting, it is recommended to have relieved fillet as indicated in Fig. 1, but you may also mount it based on R_1 dimension indicated in Table 5. The value indicated in Table 5 is recommended for the shoulder height on the mating side.

3 Mounting

The fixing thread depth of fixing screws must not exceed the maximum fixing thread depth indicated in the dimension table.

When mounting BSP and BSPG, use female screws of the table and bed, or insert screws smaller by one size to the female screws. However, note that BSP 715 SL through BSP 740 SL cannot be mounted from the inside of the table and bed.

When mounting the track rail of BSR, use female screws of the track rail or insert screws smaller by one size to the female screws. However, note that BSR 1530 SL through BSR 2040 SL cannot be mounted from the inside of the track rail. In addition, when BSR 1230 SL through BSR 1260 SL are to be mounted from the inside of the track rail, contact **IKO**.

Table 5 Shoulder height and corner radius of the reference mounting surface

unit: mm

Identification number			Shoulder height h_3	Corner radius R_1 (maximum)
—	—	BSR 12	2.5	0.5
BSP 7	—	—	3	
BSP 10	—	—	4	
—	BSPG 12	—	4	
BSP 15	BSPG 15	BSR 15	5	
BSP 20	BSPG 20	BSR 20	6	
BSP 25	BSPG 25	BSR 25	6	

4 Tightening torque for fixing screw

If the fixing force of BSP, BSPG and BSR toward the mating surface is too strong, performance and accuracy are adversely affected. Although it depends on material, rigidity and finishing condition of the mating surface, it is generally recommended to use smaller tightening torque for fixing screws and use value comparable to Table 6. In addition, use a stopper measure such as adhesive agent if fixing screw may be loosened by vibration, etc.

Table 6 Tightening torque for fixing screw

Bolt size	Tightening torque N · m
M2 × 0.4	0.065
M2.3 × 0.4	0.10
M2.6 × 0.45	0.15
M3 × 0.5	0.24

Limited linear motion type

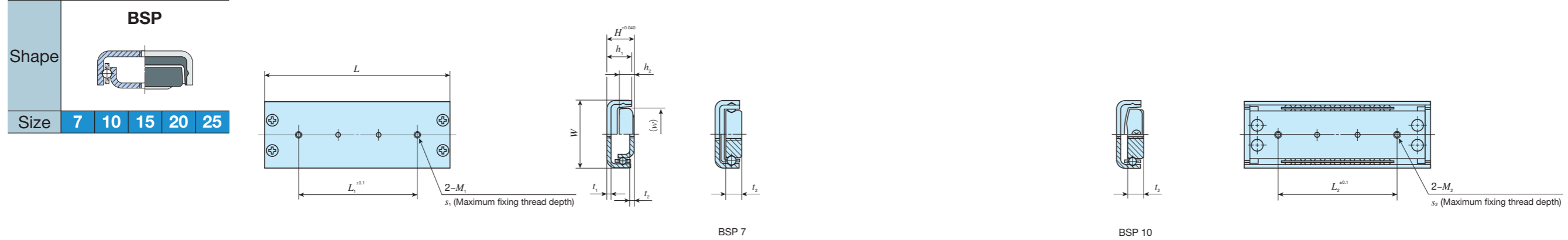

Identification number	Mass (Ref.) g	Nominal dimensions mm				Table mounting dimensions mm						Bed mounting dimensions mm						Basic dynamic load rating C N	Basic static load rating C ₀ N
		W	H	L	Maximum stroke length	L ₁	M ₁	Maximum fixing thread depth s ₁	h ₁	t ₁	w	L ₂	M ₂	Maximum fixing thread depth s ₂	h ₂	t ₂			
BSP 7 15 SL ⁽¹⁾	2.1	7	4	15	9	5	M2	1	3.4	0.9	3.6	5	M2	2	-	2	93.3	42.0	
BSP 7 20 SL ⁽¹⁾	2.8			20		10						10					134	70.0	
BSP 7 30 SL ⁽¹⁾	4.2			30		20						20					170	98.0	
BSP 7 40 SL ⁽¹⁾	5.6			40		30						30					203	126	
BSP 10 25 SL	6.2	10	6	25	15	15	M2.6	1.5	5.8	1.1	6.2	15	M2.6	2.7	3.7	2.7	340	156	
BSP 10 35 SL	8.8			35		25						25					398	194	
BSP 10 45 SL	11.3			45		35						35					453	233	
BSP 15 30 SL	11	15	8	30	22	14	M3	2.5	7	1.2	11.2	14	M3	3	4.5	1.2	395	194	
BSP 15 40 SL	14.7			40		24						24					550	311	
BSP 15 50 SL	18.4			50		32						34					644	389	
BSP 15 60 SL	22.1			60		40						40					732	467	
BSP 20 40 SL	23.7	20	10	40	22	24	M3	3.2	9	1.4	16	24	M3	3.5	6.2	1.4	726	386	
BSP 20 50 SL	29.7			50		28						34					866	496	
BSP 20 60 SL	35.7			60		34						40					998	606	
BSP 20 70 SL	41.7			70		40						45					1 120	717	
BSP 20 80 SL	47.6			80	53	50						50					1 180	772	
BSP 25 50 SL	37.6	25	10	50	26	34	M3	3.5	9	1.6	20.5	34	M3	3	5.7	1.6	866	496	
BSP 25 60 SL	45.3			60		32						40					998	606	
BSP 25 70 SL	52.9			70		40						45					1 120	717	
BSP 25 80 SL	60.5			80		51						50					1 180	772	
BSP 25 100 SL	75.8			100		63						60					1 410	992	

Note (1) BSP 715 SL through BSP 740 SL cannot be mounted from the inside of the table and bed.

Built-in rack & pinion type

Shape	BSPG			
Size	12	15	20	25



Identification number	Mass (Ref.) g	Nominal dimensions mm				Table mounting dimensions mm						Bed mounting dimensions mm						Basic dynamic load rating C N	Basic static load rating C ₀ N
		W	H	L	Maximum stroke length	L ₁	M ₁	Maximum fixing thread depth s ₁	h ₁	t ₁	L _b	w	L ₂	M ₂	Maximum fixing thread depth s ₂	h ₂	t ₂		
BSPG 12 25 SL	6.5	12	6	25	14	15	M2.6	2	5.2	1.2	23.6	7.6	15	M2.6	2	3	1	244	131
BSPG 12 35 SL	9.0			35	24	24					33.6		24					299	175
BSPG 12 45 SL	11.6			45	34	34					43.6		34					350	219
BSPG 15 40 SL	15.8	15	8	40	24	24	M3	2.5	7	1.2	37	9.6	24	M3	3	4.5	1.2	550	311
BSPG 15 50 SL	19.6			50	32	34					47		34					644	389
BSPG 15 60 SL	23.5			60	40	40					57		40					732	467
BSPG 20 40 SL	25.5	20	10	40	22	24	M3	3.2	9	1.4	37	13.8	24	M3	3.5	6.2	1.4	726	386
BSPG 20 50 SL	31.8			50	28	34					47		34					866	496
BSPG 20 60 SL	38.1			60	34	40					57		40					998	606
BSPG 20 70 SL	44.4			70	40	45					67		45					1 120	717
BSPG 20 80 SL	50.5			80	47	50					77		50					1 240	827
BSPG 25 50 SL	40.3	25	10	50	26	34	M3	3.5	9	1.6	46	18.4	34	M3	3	5.7	1.6	866	496
BSPG 25 60 SL	48.3			60	32	40					56		40					998	606
BSPG 25 70 SL	56.2			70	38	45					66		45					1 120	717
BSPG 25 80 SL	64.1			80	44	50					76		50					1 240	827
BSPG 25 100 SL	80.0			100	56	60					96		60					1 460	1 050

IKO Precision Linear Slide

Endless linear motion type

Shape	BSR			
Size	12	15	20	25



Identification number	Mass (Ref.) g	Nominal dimensions mm				Slide Unit mm			Mounting dimensions			Track rail mounting dimensions mm				Basic dynamic load rating C N	Basic static load rating C ₀ N	
		W	H	L	Maximum stroke length	w	L ₀	L ₁	M ₁	Maximum fixing thread depth s ₁	t ₁	L ₂	M ₂	Maximum fixing thread depth s ₂	h			t ₂
BSR 12 30 SL ⁽¹⁾	5.8	12	4.5	30	13	9.8	21.5	15	M2	1.3	0.9	15	M2	1.6	4	0.9	214	140
BSR 12 40 SL ⁽¹⁾	7.0			40	23							20						
BSR 12 50 SL ⁽¹⁾	8.2			50	33							34						
BSR 12 60 SL ⁽¹⁾	9.3			60	43							40						
BSR 15 30 SL ⁽²⁾	12.6	15	8	30	10	12.2	30	24	M3	1.8	1	14	M3	3	7	1.2	543	311
BSR 15 40 SL	14.8			40	20							24						
BSR 15 50 SL	17.1			50	30							34						
BSR 15 60 SL	19.3			60	40							40						
BSR 20 40 SL ⁽²⁾	27.6	20	10	40	12	16.8	40	32	M3	2.2	1.4	24	M3	3.5	9	1.4	921	551
BSR 20 50 SL	31.1			50	22							34						
BSR 20 60 SL	34.6			60	32							40						
BSR 20 70 SL	38.1			70	42							45						
BSR 20 80 SL	41.6	25	10	80	52	21.4	50	42	M3	2.4	1.6	50	M3	3.5	9	1.6	1 170	772
BSR 25 70 SL	53.8			70	33							45						
BSR 25 80 SL	58.4			80	43							50						
BSR 25 100 SL	67.4			100	63							60						

Notes ⁽¹⁾ When BSR 1230 SL through BSR 1260 SL are to be mounted from the inside of the track rail, contact IKO.
⁽²⁾ BSR 1530 SL and BSR 2040 SL cannot be mounted from the inside of the track rail.

BSU...A
BSU...A
BSU...A

Linear Slide Unit

BSU...A

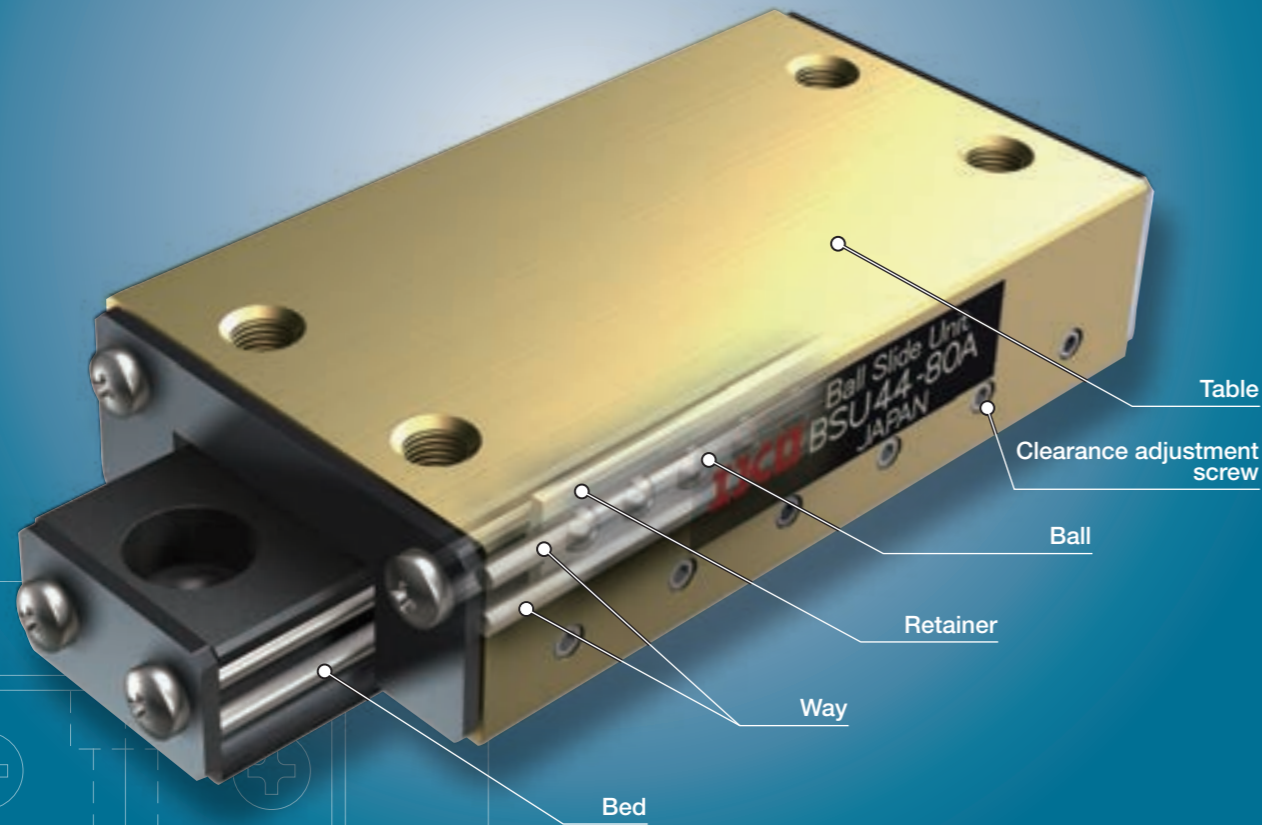

Points

1 Light weight linear motion guide unit

Since the product uses aluminum alloy for table and bed, it is a light weight and compact limited linear motion guide unit.

3 Easy mounting

Since the product is properly preloaded, it can easily gain a stable linear motion only by fixing it against precisely grounded mounting surface with bolts.

2 Smooth operations

Since the ball is guided by the retainer made of synthetic resin and rotates on high accuracy round shank way, it can obtain a light and smooth motion.

4 Excellent corrosion resistance

The ball and way are made of stainless steel and the surface of table and bed have anodic oxidization coating, allowing high corrosion resistance.

Identification Number and Specification

Example of an identification number

The specification of BSU...A series is indicated by the identification number. Indicate the identification number, consisting of a model code and dimensions for each specification to apply.

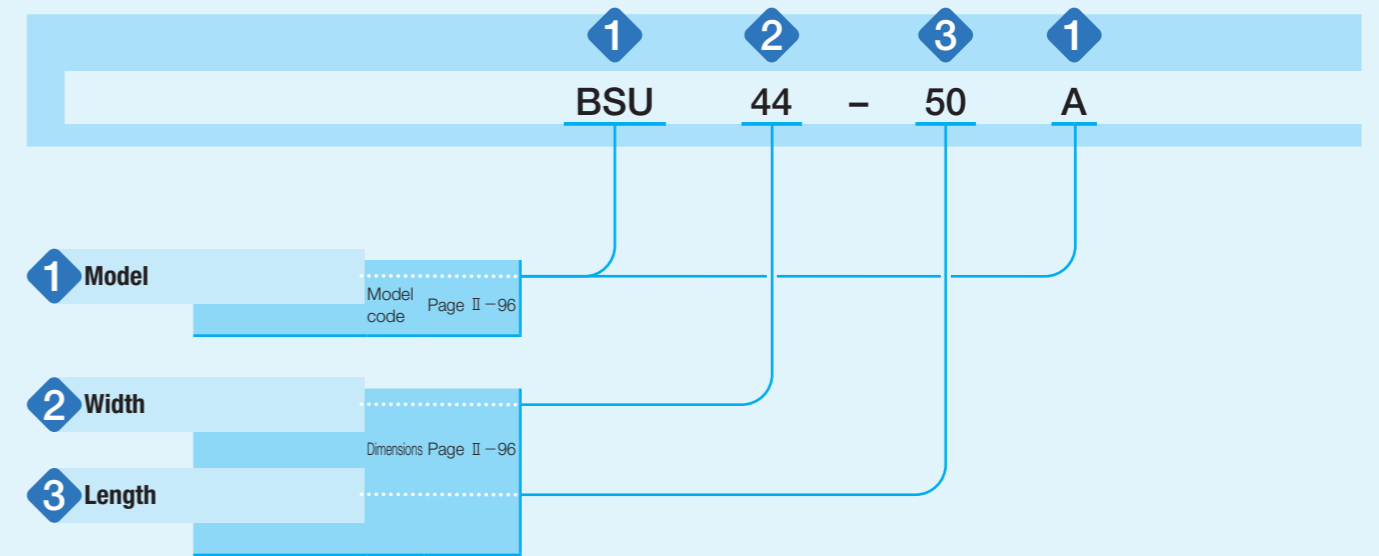

Identification Number and Specification

1 Model	Linear Slide Unit	: BSU...A
	For applicable models, width and length, see Table 1.	
2 Width	44, 66	Indicate the table width in mm. For applicable models, width and length, see Table 1.
3 Length		Indicate the length in mm. For applicable models, width and length, see Table 1.

Table 1 Width and length of BSU...A series

unit: mm

Shape	Model	Width	Length				
			50	80	100	125	150
	BSU...A	44	○	○	○	-	-
		66	-	-	○	○	○

Allowable Load

Allowable load refers to load of smooth rolling motion on contact surface to which maximum contact stress is applied and the sum of whose elastic deformation of rolling elements and raceway is small.

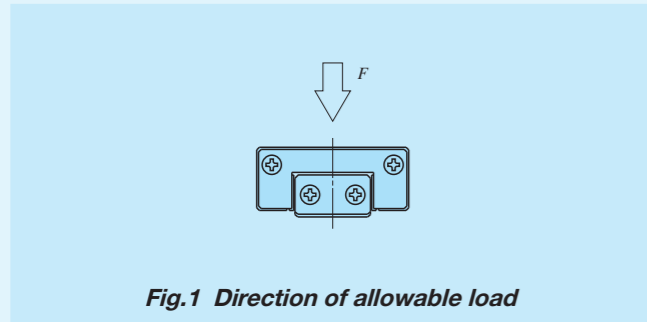

Lubrication

Grease is not pre-packed in the BSU...A series, so perform adequate lubrication as needed. Perform cleaning with clean solution before mounting and apply high-quality lubrication oil or grease to the raceway before use.

Accuracy

① Running accuracy

Parallelism at the table center against the bed mounting surface (see Fig. 2): 10 μm / 10 mm

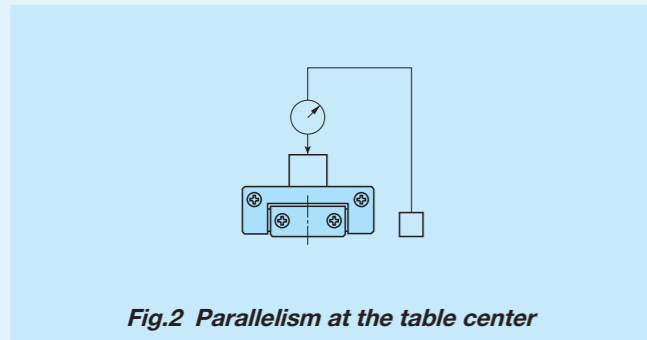

② Allowance of deviation at the table center

Deviation at the table center after stroking the table and returning to the same position (see Fig. 3): 1.5 μm

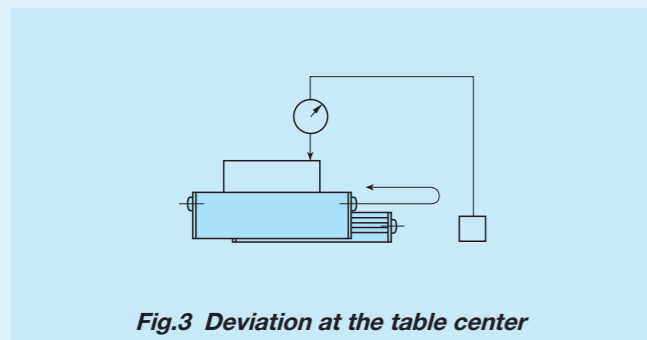

Precaution for Use

① Handling

When high running accuracy is required, set the load point at the center of the table (or bed) and use with sufficient stroke length.

For the BSU...A series, the retainer may be deviated from the right position due to offset load or irregular and high-velocity motion, etc. Fully stroke it once in certain operating time or certain number of reciprocating motion to correct the retainer position.

Since BSU...A series have small allowable load F , handling requires special care. Especially when clearance adjustment is performed, too much tightening of clearance adjustment screw will create impression on ball or way, which can adversely affect the friction, noise and vibration of the bearing. When performing clearance adjustment, gradually rotate the clearance adjustment screw by checking the motion status and paying special attention.

② Operating temperature

The table and bed of BSU...A series are made of aluminum alloy, and the clearance may change by the operating temperature. When using in the temperature outside the normal temperature, contact **IKO**. When using in wide operating temperature range, it is recommended to use **IKO** High Rigidity Precision Linear Slide Unit.

③ Maximum velocity

Operating velocity should not exceed 30 m/min during operation.

Precaution for Mounting

① Mounting

The fixing thread depth of fixing screws must not exceed the maximum fixing thread depth indicated in the dimension table. Since the fixing screw hole for the table is penetrated, the bed or retainer will be pushed by the screw if the fixing thread depth is too deep, and the running accuracy and life may be adversely affected.

② Tightening torque for fixing screw

Typical tightening torque for mounting of the BSU...A series to the steel mating member material is indicated in Table 2. If the mating member material is cast iron or aluminum alloy, reduce the tightening torque depending on the strength characteristics of the mating member material.

Table 2 Tightening torque for fixing screw

Bolt size	Tightening torque N · m
M5×0.8	5.0

Remark: The tightening torque is calculated based on property division A2-70 of stainless steel hexagon socket head bolt.

IKO Linear Slide Unit

Shape	BSU...A	
Size	44	66

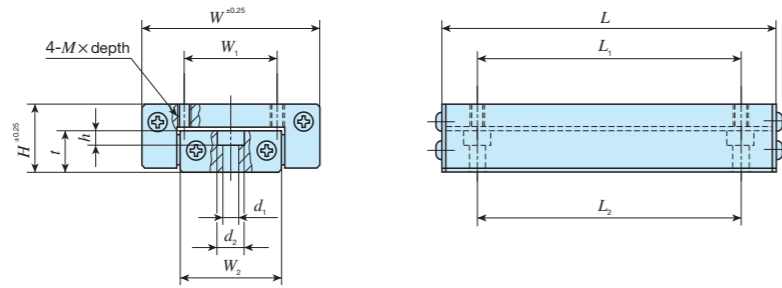

Identification number	Mass (Ref.) g	Nominal dimensions mm				Table mounting dimensions mm				Bed mounting dimensions mm					Allowable load <i>F</i> N
		<i>H</i>	<i>W</i>	<i>L</i>	Stroke length	<i>W</i> ₁	<i>L</i> ₁	<i>M</i> ×depth	<i>W</i> ₂	<i>t</i>	<i>L</i> ₂	<i>d</i> ₁	<i>d</i> ₂	<i>h</i>	
BSU 44- 50 A	110	20	44	50	25	20	35	M5×7	21.8	12.3	35	5.3	10	5.3	98.1
BSU 44- 80 A	175			80	50		65				65				177
BSU 44-100 A	220			100	75		85				85				235
BSU 66-100 A	420	25	66	100	50	35	75	M5×8	37	16	75	5.3	10	5.3	265
BSU 66-125 A	525			125	75		100				100				392
BSU 66-150 A	625			150	100		125				125				510

BWU · BSP(G)
 BSU...A

Linear Ball Spline

C-Lube Linear Ball Spline MAG

Linear Ball Spline G

Block Type Linear Ball Spline

Stroke Ball Spline



Excellent features of compact linear structure by **four-points contact** in

ball spline realized by a simple **two-row raceways**

IKO Linear Ball Spline is a linear motion rolling guide in which an external cylinder or slide unit makes linear motion along the spline shaft. Since the structure lets a ball to rotate on the spline track groove, it can receive not only the radial load but also rotating torque. Therefore it best fits the structure in which torque transmission and linear motion take place in parallel.



High rigidity in a compact size

The structure places large diameter balls in two rows and has four-point contact with the track, allowing greater rigidity and compact design.

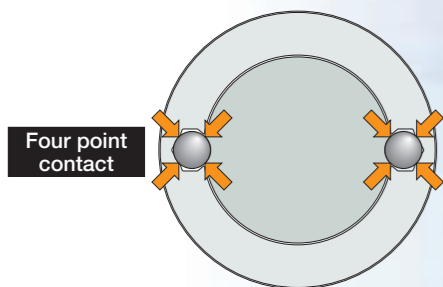

For the load from all directions it gives a good balance and high rigidity!

Allows high accuracy and accurate positioning

Preload removes the clearance along the rotation direction, allowing accurate positioning along the rotation direction.

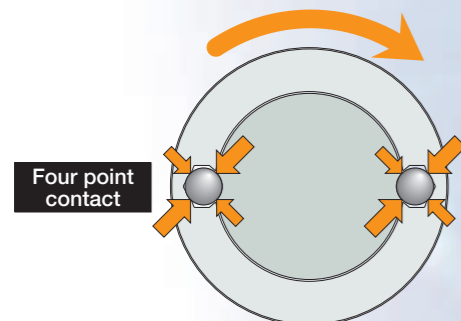

No play along the rotation direction!

Low frictional resistance and smooth motion

The optimum design based on the thorough analysis of ball recirculating route realized low frictional resistance and smooth linear motion durable for high speed operations.



Both high speed durability performance and maintenance free performance are achieved

C-lube Linear Ball Spline MAG realizes a long term maintenance free using the built-in lubrication parts C-Lube for ball recirculation way in external cylinder. Since the lubrication oil inside C-Lube maintains the lubrication performance for a long time, it reduces the annoying lubricating management works and also allows total system cost saving by reducing the oil supply structures.

Durability test assuming the chip mounter

〈Test conditions〉

Lubrication conditions	Only lubrication oil inside C-lube, with no pre-packed grease	
Test method	Vibration test machine	
Operation condition	Posture	Vertical
	Maximum velocity	860 mm/s
	Acceleration	10 G
	Number of cycle	18.2 Hz
	Stroke length	15 mm

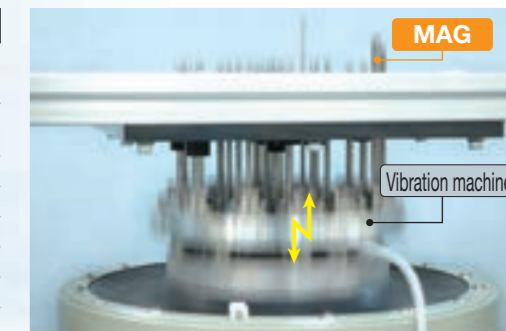

〈Result〉

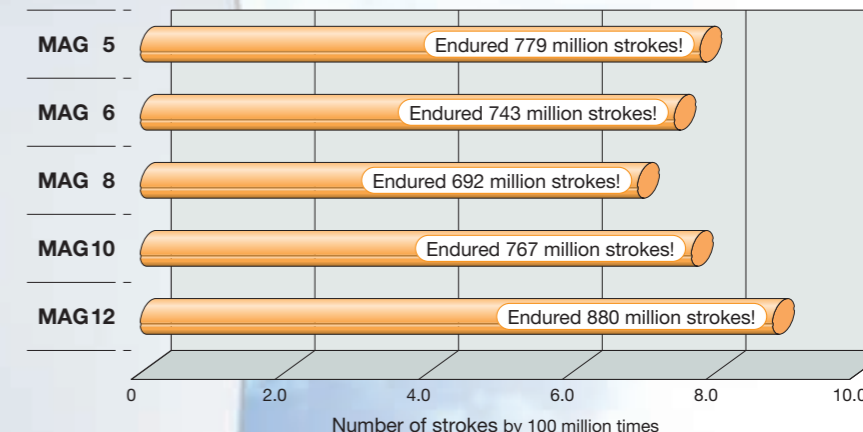

Endured total strokes of 200 million times without a problem, only by lubrication oil inside C-Lube, for vertical shaft and super high tact operation!
Realized the maintenance free of 10 years of use equivalent to 10 years, in the test condition assuming the use for general chip mounters!!

Achieved maintenance free of **more than 600 million total strokes** in this severe operation conditions!!

Wide variation

A wide variety of models and sizes, such as super miniature size of 2 mm spline shaft diameter, block types and limited stroke types, is provided for your selection to meet each requirement.

	Series	Model	Size	Spline shaft diameter	
				Min	Max
C-Lube Linear Ball Spline	MAG	6 models	6 sizes	4 ~ 12 mm	
	LSAG	8 models	14 sizes	2 ~ 50 mm	
Block Type Linear Ball Spline	LSB	3 models	7 sizes	6 ~ 25 mm	
Stroke Ball Spline	LS	2 models	3 sizes	4 ~ 6 mm	

Free combination is enabled for model/accuracy/preload!!

Extreme interchangeable system

Interchangeable specification

Interchangeable specification has realized the unparalleled high interchangeability in the background of unique high processing technology, by severely managing the dimensions of external cylinder, slide unit and spline shaft. This feature allows independent handling of external cylinder or slide unit and spline shaft, thus allowing you to select the free combination and to order any products, for any volume and at any necessary time.

Requirements of ;	Interchangeable specification realizes ;
<ul style="list-style-type: none"> Wish to improve the rigidity and life of machines Wish to improve the accuracy of machines Wish to replace the external cylinders or slide units immediately The number of external cylinders or slide units is in short Wish to replace the spline shaft immediately The length of spline shaft is not sufficient Wish to store only the external cylinders or slide units in stock for emergency 	<ul style="list-style-type: none"> Wish to prepare for a sudden design change Wish to select freely the combination of high accuracy and preload Independent handling of external cylinders or slide units and spline shafts Free and independent combination of external cylinders or slide units and spline shafts Compactness - independent storing of external cylinders or slide units and spline shafts

Select the products as many as you wish.

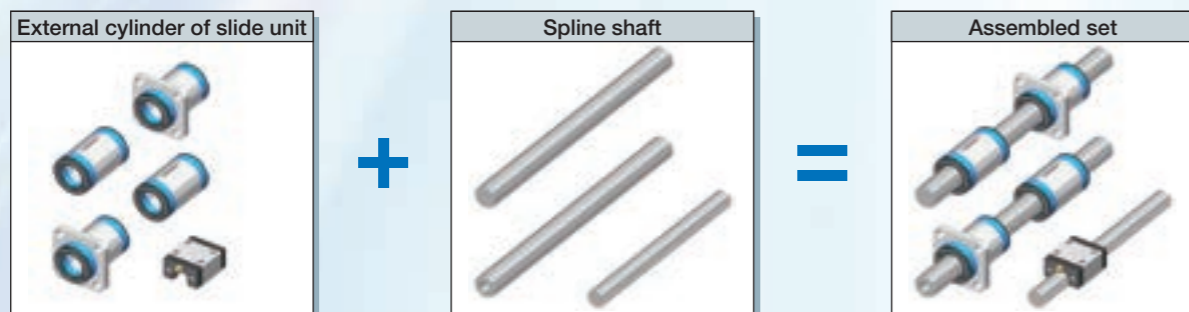

External cylinder interchangeability / unit interchangeability

A wide variety of models with different sectional shape and length are provided, for free replacement on the same spline shaft.

External cylinder interchangeability	Spline shaft interchangeability
Shape of external cylinders Standard type Flange type	Spline shaft High carbon steel spline solid shaft High carbon steel spline hollow shaft Stainless steel spline solid shaft
Length of external cylinder Standard Long	
Slide unit interchangeability Slide unit shape	Spline shaft interchangeability Spline shaft

C-Lube Linear Ball Spline MAG / Linear Ball Spline G

Block Type Linear Ball Spline

Free selection is possible for external cylinders or slide units and spline shafts!

Accuracy interchangeability

The simple structure of four-contact in two-row raceway yields small manufacturing errors or accuracy measurement errors, allowing the maintenance of each raceway in the high dimensions accuracy. Two accuracy classes of ordinary and high level are provided, to support even high traveling accuracy purposes.

It allows the accuracy improvement of units without design changes!

Preload interchangeability

The high accuracy dimensions management utilizing the simple structure achieved the interchangeability of preloaded external cylinders and slide units. It supports the applications requiring the rigidity of one higher rank.

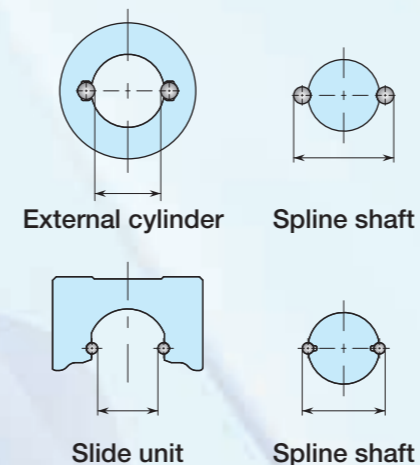

Rigidity is necessary after all!

It allows the rigidity improvement of units without design changes!

Maintenance free is achieved only by replacing the external cylinder!

By exchanging the external cylinder of Linear Ball Spline G of interchangeable specification with an external cylinder of C-Lube Linear Ball Spline G, you can achieve the maintenance free without changing the spline shaft.

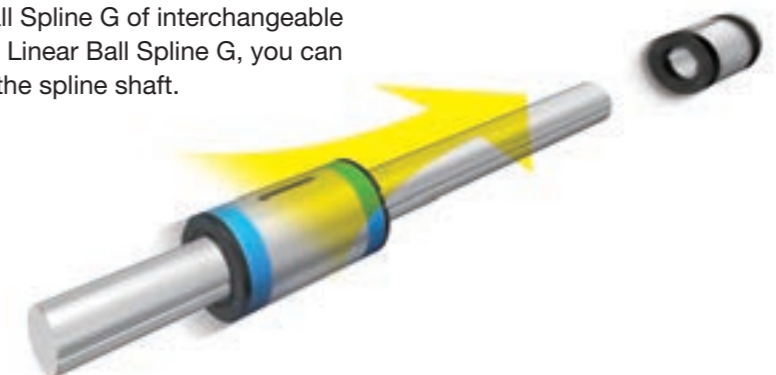

C-Lube Linear Ball Spline MAG

MAG



Long term maintenance free supported!

The aquamarine end plate is the symbol of maintenance free.



Points

1 Compact size

Uses a unique ball retaining mechanism without using a retainer, allowing a small external cylinder outside diameter against shaft diameter.

2 Wide range of variations for your needs

The external cylinder shape can be selected from two types, the standard (cylindrical shape) type and the flange type, and there are two types with different length of external cylinder with same section. Also for spline shaft, the solid shaft and the hollow shaft that allows piping/wiring/air removal are prepared for your selection to meet the requirements of mechanical/unit specifications.

3 Extremely small size realized by simple structure

The minimum size LSAG2 realizes an unparalleled small size of 2 mm shaft diameter and 6 mm external cylinder's outside diameter.

4 Stainless steel shaft with high corrosion resistance

The spline shafts made of stainless steel are highly corrosion-resistant. They are suitable where rust prevention oil is not preferred, such as in a cleanroom environment.

Identification Number and Specification

Example of an identification number

The specifications of MAG and LSAG series are indicated by the identification number. Indicate the identification number, consisting of a model code, dimensions, a part code, a preload symbol, a classification symbol, an interchangeable code, and any supplemental codes for each specification to apply.

	1	2	3	4	5	6	7	8	9	10
Non-interchangeable specification										
Assembled set	MAG	L	T	5	C1	R150	T ₁	H		/N
Interchangeable specification										
Single external cylinder	MAG	L		5	C1		T ₁	H	S1	/N
Single spline shaft (1)	LSAG		T	5		R150		H	S1	
Assembled set	MAG	L	T	5	C1	R150	T ₁	H	S1	/N

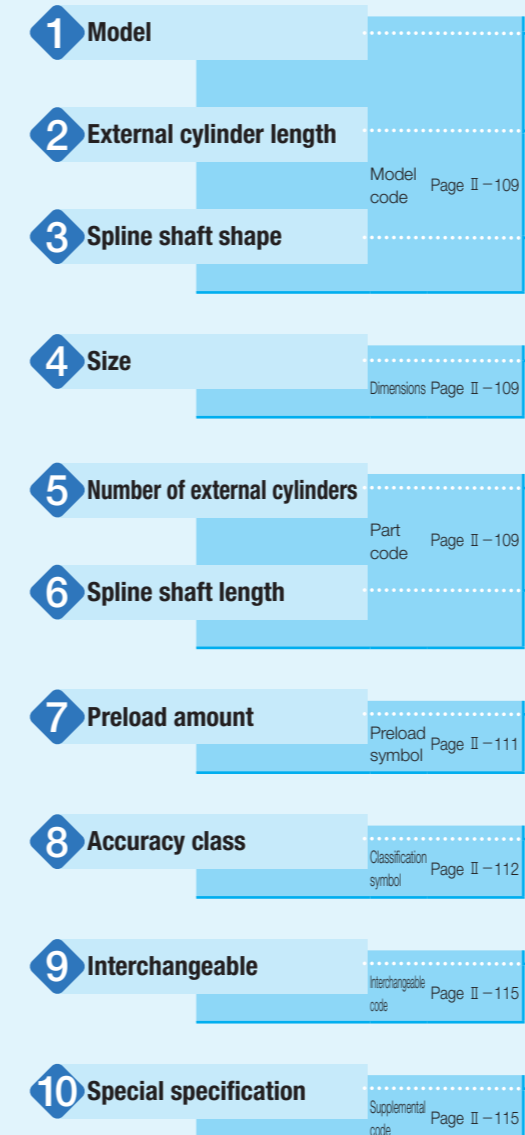

MAG · LSAG
LSB · LS





Note (1) Indicate "LSAG" (solid shaft) or "LSAGT" (hollow shaft) for the model code of the single spline shaft regardless of the series and the combination of external cylinder models.

Identification Number and Specification — Model · External Cylinder Length ·

1 Model	C-Lube Linear Ball Spline MAG (MAG series)	Standard type : MAG Flange type : MAGF
	Linear Ball Spline G ⁽¹⁾ (LSAG series)	Standard type : LSAG Flange type : LSAGF
<p>For applicable models and sizes, see Table 1. Indicate "LSAG" (solid shaft) or "LSAGT" (hollow shaft) for the model code of the single spline shaft regardless of the series and the combination of external cylinder models.</p> <p>Note ⁽¹⁾ This model has no built-in C-Lube.</p>		
2 External cylinder length	Standard : No symbol Long : L	For applicable models and sizes, see Table 1.
3 Spline shaft shape	Solid shaft : No symbol Hollow shaft : T	For applicable models and sizes, see Table 1.
4 Size	2, 3, 4, 5, 6, 8, 10, 12, 15 20, 25, 30, 40, 50	For applicable models and sizes, see Table 1.
5 Number of external cylinders	: C○	For an assembled set, indicates the number of external cylinders assembled on a spline shaft. For a single external cylinder, only "C1" is specified.
6 Spline shaft length	: R○	The spline shaft length is indicated in mm. For standard and maximum lengths, see the dimension table.

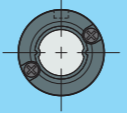
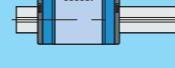
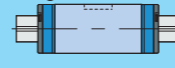
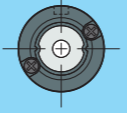
Spline Shaft Shape · Size · Number of External Cylinders · Spline Shaft Length —

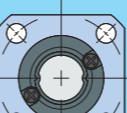
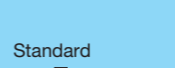
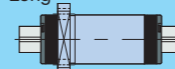
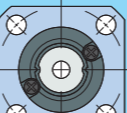
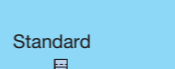
Table 1 Models and sizes of MAG and LSAG series

Shape	External cylinder length	Model	Size													
			2	3	4	5	6	8	10	12	15	20	25	30	40	50
Standard type Solid shaft 	Standard 	MAG	-	-	○	○	○	○	○	○	-	-	-	-	-	-
		LSAG	○	○	○	○	○	○	○	○	○	○	○	○	○	○
	Long 	MAGL	-	-	○	○	○	○	-	-	-	-	-	-	-	-
		LSAGL	-	-	-	○	○	○	○	○	○	○	○	-	-	-
Standard type Hollow shaft 	Standard 	MAGT	-	-	○	○	○	○	○	○	-	-	-	-	-	
		LSAGT	-	-	○	○	○	○	○	○	-	-	-	-	-	
	Long 	MAGLT	-	-	○	○	○	○	-	-	-	-	-	-	-	
		LSAGLT	-	-	-	○	○	○	○	○	-	-	-	-	-	
Flange type Solid shaft 	Standard 	MAGF	-	-	-	○	○	○	○	○	-	-	-	-	-	
		LSAGF	○	○	○	○	○	○	○	○	○	○	○	○	-	
	Long 	LSAGFL	-	-	-	○	○	○	○	○	○	○	○	-	-	
		Flange type Hollow shaft 	Standard 	MAGFT	-	-	-	○	○	○	○	○	-	-	-	-
LSAGFT	-			-	○	○	○	○	○	○	-	-	-	-		
Long 	LSAGFLT		-	-	-	○	○	○	○	○	-	-	-	-		

Remark: For the models indicated in , the interchangeable specification is available.

MAG · LSAG
LSB · LS

—Preload Amount—

7	Preload amount	Clearance Standard	: T ₀	Specify this item for an assembled set or a single external cylinder. For details of the preload amount, see Table 2. For applicable preload types, see Table 3.
		Light preload	: No symbol	
			: T ₁	

Table 2 Preload amount

Preload type	Item	Preload symbol	Preload amount N	Operational conditions
Clearance		T ₀	0 ⁽¹⁾	• Very light motion
Standard		(No symbol)	0 ⁽²⁾	• Light and precise motion
Light preload		T ₁	0.02 C ₀	• Almost no vibrations • Load is evenly balanced • Light and precise motion

Notes ⁽¹⁾ There is zero or subtle clearance.

⁽²⁾ Indicates zero or minimal amount of preload.

Remark: C₀ indicates the basic static load rating.

Table 3 Application of preload

Size	Preload type (preload symbol)		
	Clearance (T ₀)	Standard (No symbol)	Light preload (T ₁)
2	○	○	—
3	○	○	—
4	○	○	—
5	—	○	○
6	—	○	○
8	—	○	○
10	—	○	○
12	—	○	○
15	—	○	○
20	—	○	○
25	—	○	○
30	—	○	○
40	—	○	○
50	—	○	○

Remark: The mark indicates that interchangeable specifications products are available.

—Accuracy Class—

8	Accuracy class	Ordinary	: No symbol	For interchangeable specification products, assemble an external cylinder and a spline shaft of the same accuracy class. For applicable accuracy class, see Table 4. For details of accuracy class, see Table 5, Table 6, and Table 7.
		High	: H	
		Precision	: P	

Table 4 Application of accuracy class

Size	Class (classification symbol)		
	Ordinary (No symbol)	High (H)	Precision (P)
2	○	○	○
3	○	○	○
4	○	○	○
5	○	○	○
6	○	○	○
8	○	○	○
10	○	○	○
12	○	○	○
15	○	○	○
20	○	○	○
25	○	○	○
30	○	○	○
40	○	○	○
50	○	○	○

Remark: The mark indicates that interchangeable specifications products are available.

Table 5 Tolerance of each part

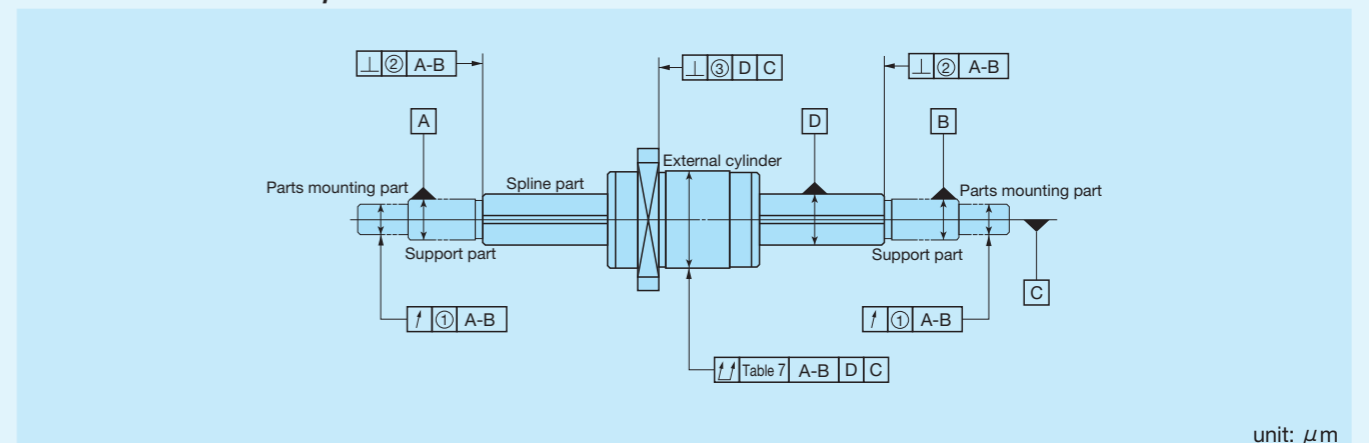

Size	Relative to axial line of supporting part of spline shaft						③ Perpendicularity of mounting surface of flange with respect to axial line of spline shaft ⁽²⁾		
	① Radial runout of periphery of parts mounting part ⁽¹⁾			② Perpendicularity of spline part end face ⁽¹⁾			Ordinary (No symbol)	High (H)	Precision (P)
	Ordinary (No symbol)	High (H)	Precision (P)	Ordinary (No symbol)	High (H)	Precision (P)			
2	33	14	8	22	9	6	27	11	8
3	33	14	8	22	9	6	27	11	8
4	33	14	8	22	9	6	27	11	8
5	33	14	8	22	9	6	27	11	8
6	33	14	8	22	9	6	27	11	8
8	33	14	8	22	9	6	27	11	8
10	41	17	10	22	9	6	33	13	9
12	41	17	10	22	9	6	33	13	9
15	46	19	12	27	11	8	33	13	9
20	46	19	12	27	11	8	33	13	9
25	53	22	13	33	13	9	39	16	11
30	53	22	13	33	13	9	39	16	11
40	62	15	15	39	16	11	46	19	13
50	62	15	15	39	16	11	—	—	—

Notes ⁽¹⁾ The values are for the processed shaft ends.

⁽²⁾ Applicable to the flange type.

Table 6 Twist of grooves with respect to effective length of the spline part
unit: μm

Accuracy class	Ordinary (No symbol)	High (H)	Precision (P)
Allowable value	33	13	6

Remark: The values can be applied to 100 mm of the effective length of the spline at any position.

Table 7 Allowable values of total radial runout of spline shaft axial line
unit: μm

Overall length of spline shaft mm		Size and accuracy class		Size								
				2, 3, 4, 5, 6, 8			10, 12			15, 20		
		Ordinary (No symbol)	High (H)	Precision (P)	Ordinary (No symbol)	High (H)	Precision (P)	Ordinary (No symbol)	High (H)	Precision (P)		
—	200	72	46	26	59	36	20	56	34	18		
200	315	133	89	57	83	54	32	71	45	25		
315	400	185	126	82	103	68	41	83	53	31		
400	500	236	163	108	123	82	51	95	62	38		
500	630	—	—	—	151	102	65	112	75	46		
630	800	—	—	—	190	130	85	137	92	58		
800	1 000	—	—	—	—	—	—	170	115	75		
1 000	1 250	—	—	—	—	—	—	—	—	—		

Overall length of spline shaft mm		Size and accuracy class		Size					
				25, 30			40, 50		
		Ordinary (No symbol)	High (H)	Precision (P)	Ordinary (No symbol)	High (H)	Precision (P)		
—	200	53	32	18	53	32	16		
200	315	58	39	21	58	36	19		
315	400	70	44	25	63	39	21		
400	500	78	50	29	68	43	24		
500	630	88	57	34	74	47	27		
630	800	103	68	42	84	54	32		
800	1 000	124	83	52	97	63	38		
1 000	1 250	151	102	65	114	76	47		

Table 8 Measuring methods of accuracy

Item	Measuring method	Illustration of measuring method
(1) Radial runout of periphery of parts mounting part with respect to axial line of supporting part of spline shaft (see Table 5 ①)	While supporting the spline shaft at its support part, place the dial gage probes on the outer peripheral faces of the parts mounting part and measure the deflection from one rotation of the spline shaft.	
(1) Perpendicularity of spline part end face with respect to axial line of supporting part of spline shaft (See Table 5 ②)	While supporting the spline shaft at its support part and one spline shaft end, place the dial gage probes on the spline end faces and obtain perpendicularity by measuring the deflection from one rotation of the spline shaft.	
Perpendicularity of mounting surface of flange with respect to axial line of spline shaft (see Table 5 ③)	While supporting the spline shaft at both centers and the outer peripheral faces of the spline shaft near the external cylinder and fixing the external cylinder on the spline shaft, place the dial gage probe on the flange mounting surface and obtain perpendicularity by measuring the deflection from one rotation of the spline shaft.	
Twist of grooves with respect to effective length of the spline part (see Table 6)	While supporting the spline shaft fixed, apply a unidirectional torsion moment load to the external cylinder (or measuring unit), place the dial gage probe vertically to the spline shaft on the side face of the sunk key attached on the external cylinder, and measure the deflection when the external cylinder and the dial gage probe are moved 100 mm in the axial direction at any position on the effective length of the spline shaft. However, the dial gage probe should be applied as near as possible to the outer peripheral face of the external cylinder.	
Total radial runout of axial line of spline shaft (see Table 7)	While supporting the spline shaft at its support part or at both centers, place a dial gage probe on the outer peripheral face of the external cylinder (or measuring unit) and measure the deflection from one rotation of the spline shaft at several positions in the axial direction to obtain the maximum value.	

Note (1) The accuracy are for the processed shaft ends.

9 Interchangeable	S1 specification	: S1	This is specified for the interchangeable specifications.
	S2 specification	: S2	Assemble a spline shaft and an external cylinder with the same interchangeable code. Performance and accuracy of "S1" and "S2" are the same.
	Non-interchangeable specification	: No symbol	For applicable models and sizes, see Table 1. "No symbol" is indicated for non-interchangeable specification.

10 Special specification	/BS, /N, /OH, /Q, /RE, /S, /Y	For applicable special specifications, see Table 9.1 and Table 9.2.
		For combination of multiple special specifications, see Table 10. For details of special specifications, see pages II-116 and II-117.

Table 9.1 Application of special specifications (Interchangeable specification, single external cylinder, and assembled set)

Special specification	Supplemental code	Size													
		2	3	4	5	6	8	10	12	15	20	25	30	40	50
No seal	/N	—	—	—	○	○	○	○	○	○	○	○	○	—	—
Oil hole (1)	/OH	—	—	—	○	○	○	○	○	○	○	○	○	—	—
With C-Lube plate (1)	/Q	—	—	—	○	○	○	○	○	—	—	—	—	—	

Note (1) Applicable to LSAG series.

Table 9.2 Application of special specifications (Non-interchangeable specification)

Special specification	Supplemental code	Size													
		2	3	4	5	6	8	10	12	15	20	25	30	40	50
Stainless steel end plate (1)	/BS	—	—	—	○	○	○	○	○	—	—	—	—	—	
No seal	/N	—	—	—	○	○	○	○	○	○	○	○	○	○	
Oil hole (1)	/OH	—	○	○	○	○	○	○	○	○	○	○	○	○	
With C-Lube plate (1)	/Q	—	—	—	○	○	○	○	○	—	—	—	—	—	
Special environment seal (1)	/RE	—	—	—	○	○	○	○	○	—	—	—	—	—	
Stainless steel spline shaft (2)	/S	—	—	—	○	○	○	○	○	○	○	○	—	—	
Specified grease (1)	/Y	—	—	—	○	○	○	○	○	—	—	—	—	—	

Notes (1) Applicable to LSAG series.

(2) Applicable to solid shaft.

Table 10 Combination of supplemental codes

N	●														
OH	●	○													
Q	●	○	○												
RE	●	—	●	●											
S	●	●	●	●	●										
Y	●	●	●	—	●	●									
	BS	N	OH	Q	RE	S									

Remarks 1. The combination of "—" shown in the table is not available.

2. Contact **IKO** for the combination of the interchangeable specification marked with ●.

3. When using multiple types for combination, please indicate by arranging the symbols in alphabetical order.

Stainless steel end plate /BS

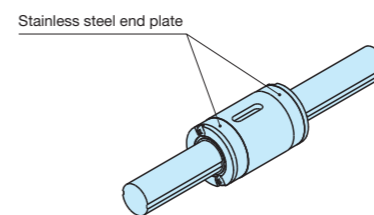

The standard synthetic resin end plates are replaced with stainless steel end plates. The total length of the external cylinder remains unchanged.

No seal /N

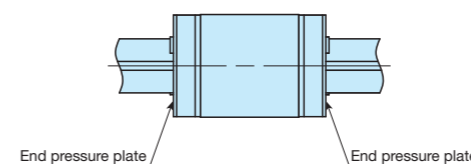

Seals at both ends of the external cylinder can be replaced with end pressure plates, which do not come in contact with the spline shaft, to reduce frictional resistance. This specification is not effective for dust protection.

Oil hole /OH

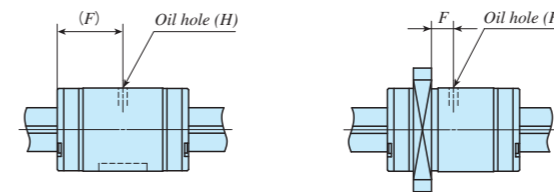

An oil hole is created on the external cylinder. For dimensions, see Table 11.1 and Table 11.2.

Table 11.1 Location and diameter of oil hole on a standard type external cylinder (Supplemental code /OH)

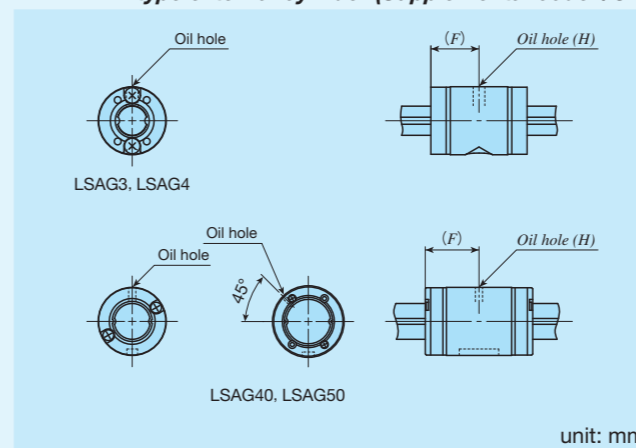

Identification number	F	H	Identification number	F	H
LSAG 4	6	1.5	—	—	—
LSAG 5	9		LSAGL 5	13	1.5
LSAG 6	10.5	LSAGL 6	15		
LSAG 8	12.5	LSAGL 8	18.5		
LSAG10	15	LSAGL10	23.5		
LSAG12	17.5	LSAGL12	27	2	
LSAG15	20	LSAGL15	32.5		
LSAG20	25	LSAGL20	35.5		
LSAG25	30	LSAGL25	42	3	
LSAG30	35	LSAGL30	49		
LSAG40	50	—	—	—	
LSAG50		—	—	—	

Remark: A typical identification number is indicated, but is applied to all LSAG series standard type models of the same size.

Table 11.2 Location and diameter of oil hole on a flange type external cylinder (Supplemental code /OH)

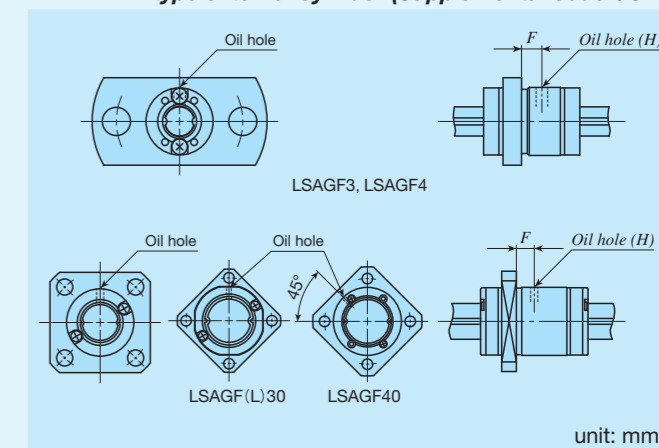

Identification number	F	H	Identification number	F	H
LSAGF 4	2.8	1.5	—	—	—
LSAGF 5			LSAGFL 5	5.8	1.5
LSAGF 6	LSAGFL 6	8			
LSAGF 8	3.5	LSAGFL 8	9.5		
LSAGF10	5	LSAGFL10	13.3		
LSAGF12	7.5	LSAGFL12	17	2	
LSAGF15	9	LSAGFL15	21.5		
LSAGF20	11	LSAGFL20	21.5		
LSAGF25	13	LSAGFL25	25	3	
LSAGF30	14	LSAGFL30	28		
LSAGF40	23.4	—	—	—	

Remark: A typical identification number is indicated, but is applied to all LSAG series flange type models of the same size.

—Special Specification—

With C-Lube plate /Q

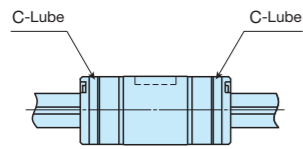

The C-Lube impregnated with lubrication oil is attached inside the seal of the external cylinder, so that the interval for reapplying lubricant can be extended. For the total length of the external cylinder with C-Lube plate, see Table 12.

Table 12 Dimension of external cylinder with C-Lube plate (Supplemental code /Q)

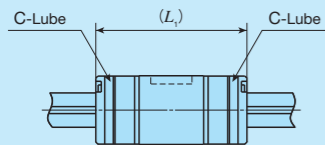

unit: mm

Identification number	L_1	Identification number	L_1
LSAG 5	24	LSAGL 5	32
LSAG 6	27	LSAGL 6	36
LSAG 8	33	LSAGL 8	45
LSAG10	38	LSAGL10	55
LSAG12	43	LSAGL12	62

- Remarks 1. The dimensions of the external cylinder with C-Lube at both ends are indicated.
 2. A typical identification number is indicated, but is applied to all LSAG series models of the same size.

Special environment seal /RE

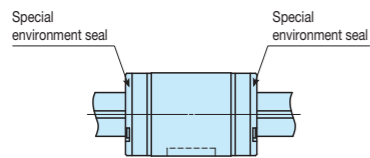

The standard seals are replaced with seals for special environment that can be used at high temperatures. The total length of the external cylinder remains unchanged.

Stainless steel spline shaft /S

The material of the solid spline shaft is changed to stainless steel. The load rating will change to a value obtained by multiplying the load rating for the steel spline shaft by a factor of 0.8.

Specified grease /YCG /YCL /YAF /YBR /YNG

The type of pre-packed grease can be changed by the supplemental code.

- ① /YCG Low Dust-Generation Grease for Clean Environment CG2 is pre-packed.
- ② /YCL Low Dust-Generation Grease for Clean Environment CGL is pre-packed.
- ③ /YAF Anti-Fretting Corrosion Grease AF2 is pre-packed.
- ④ /YBR MOLYCOTE BR2 Plus Grease [Dow Corning] is pre-packed.
- ⑤ /YNG No grease is pre-packed.

Load Direction and Load Rating

The MAG and LSAG series must be used with their load rating corrected in accordance to the load direction. The basic dynamic load rating and basic static load rating shown in the dimension table should be corrected to values in Table 13.

Table 13 Load ratings corrected for load direction

Load rating and load direction	Basic dynamic load rating			Basic static load rating		
	Load direction			Load direction		
	Downward	Upward	Lateral	Downward	Upward	Lateral
Size 2~12	C	C	1.47C	C_0	C_0	1.73 C_0
Size 15~50	C	C	1.13C	C_0	C_0	1.19 C_0

MAG · LSAG
LSB · LS

Identification number and quantity for ordering

To order an assembled set of MAG and LSAG series, please specify the number of sets based on the number of spline shafts. For single external cylinder or single spline shaft of the interchangeable specification, please specify the number of units.

Non-interchangeable specification

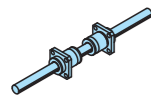

Assembled set
(When 1 set is needed)

Example of identification number indication

MAGF 10 C2 R200 T1 H /N

Order quantity
1 set

Interchangeable specification



Single external cylinder
(When 2 pieces are needed)

Example of identification number indication

MAGF 10 C1 T1 H S○ /N

Only C1 can be specified.

Please specify S1 or S2.

Order quantity
2 pieces

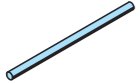

Single spline shaft
(When 1 unit is needed)

Example of identification number indication

LSAG 10 R200 H S○

Please specify S1 or S2.

Order quantity
1 unit

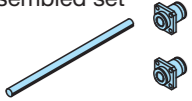

Assembled set
(When 1 set is needed)

Example of identification number indication

MAGF 10 C2 R200 T1 H S○ /N

Please specify S1 or S2.

Order quantity
1 set

Moment of Inertia of Sectional Area and Section Coefficient of Spline Shaft

Table 14 Moment of inertia of sectional area and section coefficient of spline shaft

Size	Moment of inertia of sectional area mm ⁴		Section coefficient mm ³	
	Solid shaft	Hollow shaft	Solid shaft	Hollow shaft
2	0.60	—	0.65	—
3	3.6	—	2.5	—
4	12	12	6	6
5	29	29	12	12
6	61	61	21	21
8	190	190	49	49
10	470	460	95	94
12	990	960	170	160
15	1 590	—	240	—
20	5 110	—	570	—
25	12 100	—	1 080	—
30	25 400	—	1 890	—
40	91 000	—	4 930	—
50	223 000	—	9 660	—

Dimensions of Attached Key

The MAG and LSAG series standard types have keys shown in Table 15 attached.

Table 15 Dimensions and tolerance of attached key

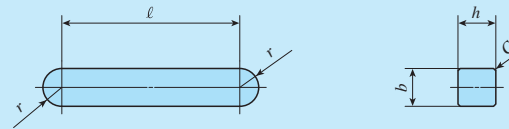

Size	<i>b</i>	Dim. <i>b</i> tolerance	<i>h</i>	Dim. <i>h</i> tolerance	<i>l</i>	<i>r</i>	<i>C</i>
5	2	+0.016 +0.006	2	0 -0.025	3.8	1	0.16~0.25
6			2.5		5.8		
8	3	3	7.8	1.5			
12	3.5	3.5	11.8	1.75			
15	4	+0.024 +0.012	4	0 -0.030	16	2	
20	5	5	21.5	2.5	23.5	2.5	
25	7	+0.030	7	0 -0.036	27.5	3.5	0.25~0.4
30	10	+0.015	8		44.3	5	
40	15	+0.036 +0.018	10	34.3	7.5	0.4~0.6	

unit: mm

Remark: No key is attached to the Size 2, 3, and 4 series. For details of how to fix the key, see page II -121.

II - 119

1N=0.102kgf=0.2248lbs.
1mm=0.03937inch

II - 120

MAG · LSAG
LSB · LS

Lubrication

Lithium-soap base grease with extreme-pressure additive (Alvania EP Grease 2 [SHOWA SHELL SEKIYU K. K.]) is pre-packed in MAG and LSAG series. Additionally, MAG series has C-Lube placed in the recirculation part of balls, so that the interval for reapplying lubricant can be extended and maintenance works such as grease job can be reduced significantly.

Since the Size 2 series do not have an oil hole, apply grease directly to the raceway part of the spline shaft for re-greasing.

Dust Protection

The external cylinders of MAG and LSAG series are equipped with special rubber seals as standard for dust protection. However, if large amount of contaminant or dust are floating, or if large particles of foreign substances such as chips or sand may adhere to the spline shaft, it is recommended to attach a protective cover to the linear motion mechanism. The Size 2, 3, and 4 series are not provided with seals. If the Size 3 and 4 series with seals is needed, contact **IKO**.

Precaution for Use

① Fitting of external cylinder

Generally, transition fit (J7) is used for fitting between the external cylinder and the housing bore. When high accuracy and high rigidity are not required, clearance fit (H7) can also be used.

② Typical mounting structure

Mounting examples of the external cylinder are shown in Fig. 1.

The rotation detent for external cylinders of the Size 2, 3, and 4 series should be mounted using the countersink provided on the external cylinder. Use screws M1.2 to M1.6 for Size 2, M1.6 to M2 for Size 3, and M2 to M2.5 for Size 4. At this point, be careful not to deform the external cylinder with screws.

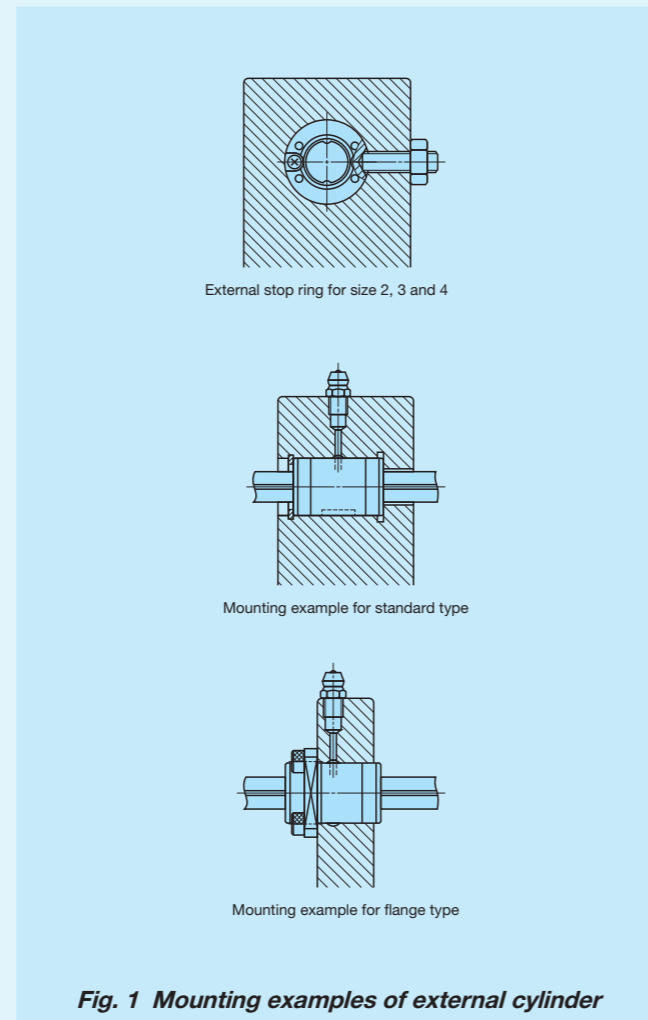

③ Multiple external cylinders used in close proximity

When using multiple external cylinders in close proximity, greater load may be applied than the calculated value depending on the accuracy of the mounting surfaces and reference mounting surfaces of the machine or device. In such cases, allowance for greater applied load than the calculated value should be made.

If two or more external cylinders are assembled on a spline shaft and two or more keys are used to fix the rotational direction of the external cylinder, the keyway position of the external cylinders are aligned before delivery. Please contact **IKO**.

④ Additional machining of spline shaft end

The spline shaft is hardened by induction hardening. When additional machining on the shaft end is needed, make sure that the maximum diameter of the shaft end machining part does not exceed the dimension d_1 in the dimension table. Spline shafts with special shaft end shapes can be prepared upon request. Contact **IKO** for further information.

⑤ Operating temperature

MAG Series contains C-Lube. The operating temperature should not exceed 80°C. The maximum operating temperature for LSAG series is 120°C and temperature up to 100°C is allowed for continuous operation. When the temperature exceeds 100°C, contact **IKO**.

When specifying LSAG series special specification with C-Lube plate (supplemental code /Q), utilize it below 80°C.

⑥ Arrangement of flange type (non-interchangeable specification) external cylinder

Table 16 shows arrangements of multiple flange type external cylinders in non-interchangeable specification. Arrangements that are not in Table 16 can be prepared upon request. Contact **IKO** for further information.

Table 16 Arrangement of flange type (Non-interchangeable specification) external cylinder

Number of external cylinders	Arrangement of external cylinders
1	
2	
3	
4	
5	
6	

⑦ When mounting multiple assembled sets at the same time

For interchangeable specification products, assemble an external cylinder and a spline shaft with the same interchangeable code ("S1" or "S2").

For non-interchangeable specification products, use the same combination of external cylinder and spline shaft upon delivery.

⑧ Assembly of external cylinder on spline shaft

When assembling the external cylinder on the spline shaft, correctly fit the grooves of the external cylinder and the spline shaft and move the external cylinder softly in parallel direction. Rough handling may result in damaging of seals or dropping of steel balls.

The non-interchangeable specification products are already adjusted so as to provide the best accuracy when the **IKO** marks of the external cylinder and the spline shaft face the same direction (see Fig. 2). Be careful not to change the assembly direction.

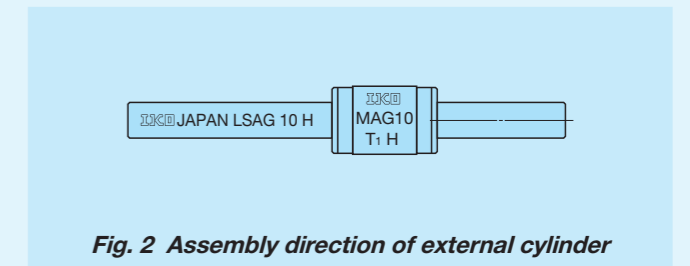

⑨ Mounting of external cylinder

When press-fitting the external cylinder to the housing, assemble them correctly by using a press and a suitable jig fixture. (See Fig. 3.)

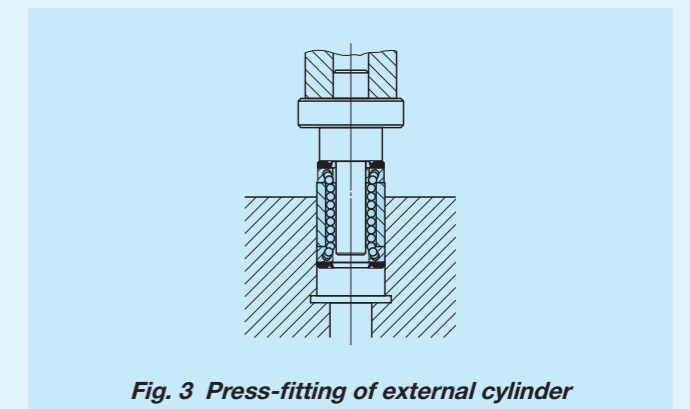

IKO C-Lube Linear Ball Spline MAG

Standard type	
Shape	MAG · LSAG
Size	2 3 4 5 6 8 10 12 15 20 25 30 40 50

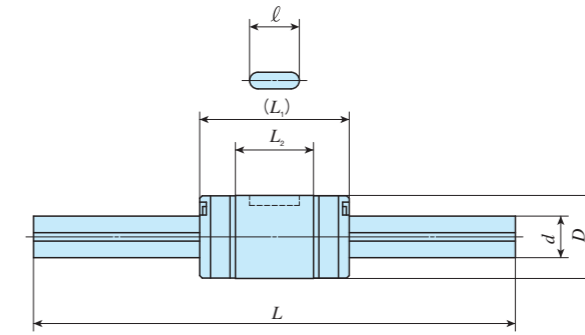
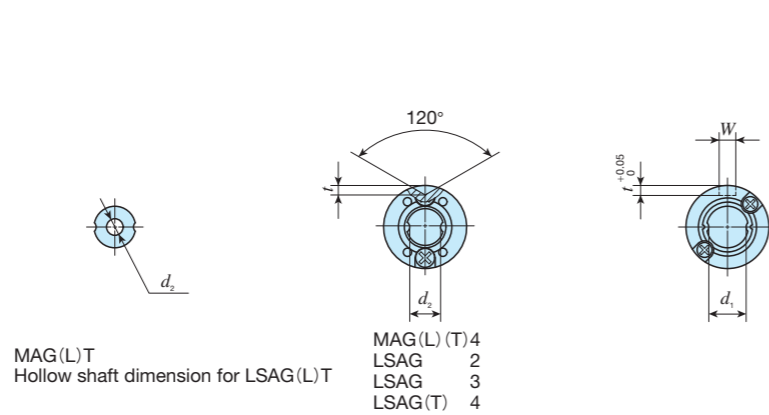

Identification number	Interchangeable	Mass (Ref.) g	External cylinder dimensions and tolerances mm										Spline shaft dimensions and tolerances mm					Basic dynamic load rating ⁽⁴⁾ C N	Basic static load rating ⁽⁴⁾ C ₀ N	Dynamic torque rating ⁽⁴⁾ T N · m	Static torque rating ⁽⁴⁾ T ₀ N · m	Static moment rating ⁽⁴⁾	
			External cylinder	Spline shaft (per 100 mm)	D	Dim. D tolerance	L ₁	L ₂	W	Dim. W tolerance	t	l	d	Dim. d tolerance	d ₁ ⁽²⁾	d ₂	L ⁽³⁾					Maximum length	T _x N · m
—	LSAG 2 ⁽¹⁾	1.0	2.3	6	$\begin{matrix} 0 \\ -0.008 \end{matrix}$	8.5	4.7	—	—	0.7	—	2	$\begin{matrix} 0 \\ -0.010 \end{matrix}$	1.2	—	50 100	100	222	237	0.28	0.30	$\begin{matrix} 0.22 \\ 1.4 \end{matrix}$	$\begin{matrix} 0.39 \\ 2.4 \end{matrix}$
—	LSAG 3 ⁽¹⁾	2.1	5.4	7	$\begin{matrix} 0 \\ -0.009 \end{matrix}$	10	5.9	—	—	0.8	—	3	$\begin{matrix} 0 \\ -0.010 \end{matrix}$	2.2	—	100 150	150	251	285	0.45	0.51	$\begin{matrix} 0.31 \\ 3.3 \end{matrix}$	$\begin{matrix} 0.53 \\ 3.3 \end{matrix}$
MAG 4 ⁽¹⁾	LSAG 4 ⁽¹⁾	2.5	9.6	8	$\begin{matrix} 0 \\ -0.009 \end{matrix}$	15	7.9	—	—	1	—	4	$\begin{matrix} 0 \\ -0.012 \end{matrix}$	3.2	1.5	100 150	200	303	380	0.70	0.87	$\begin{matrix} 0.52 \\ 3.80 \end{matrix}$	$\begin{matrix} 0.90 \\ 6.50 \end{matrix}$
MAGT 4 ⁽¹⁾	LSAGT 4 ⁽¹⁾					15											$\begin{matrix} 0.52 \\ 3.80 \end{matrix}$					$\begin{matrix} 0.90 \\ 6.50 \end{matrix}$	
MAGL 4 ⁽¹⁾	—	4.1	8.2	8	$\begin{matrix} 0 \\ -0.009 \end{matrix}$	21	13.9	—	—	—	—	—	$\begin{matrix} 0 \\ -0.012 \end{matrix}$	—	—	—	200	441	665	1.00	1.50	$\begin{matrix} 0.52 \\ 3.80 \end{matrix}$	$\begin{matrix} 0.90 \\ 6.50 \end{matrix}$
MAGLT 4 ⁽¹⁾	—					15											$\begin{matrix} 0.52 \\ 3.80 \end{matrix}$					$\begin{matrix} 0.90 \\ 6.50 \end{matrix}$	
MAG 5	LSAG 5	4.8	14.9	10	$\begin{matrix} 0 \\ -0.009 \end{matrix}$	18	9.4	2	$\begin{matrix} +0.014 \\ 0 \end{matrix}$	1.2	6	5	$\begin{matrix} 0 \\ -0.012 \end{matrix}$	4.2	2	100 150	200	587	641	1.8	1.9	$\begin{matrix} 1.0 \\ 7.9 \end{matrix}$	$\begin{matrix} 1.8 \\ 13.6 \end{matrix}$
MAGT 5	LSAGT 5					26											$\begin{matrix} 1.0 \\ 7.9 \end{matrix}$					$\begin{matrix} 1.8 \\ 13.6 \end{matrix}$	
MAGL 5	LSAGL 5	8.1	14.9	10	$\begin{matrix} 0 \\ -0.009 \end{matrix}$	26	16.9	2	$\begin{matrix} +0.014 \\ 0 \end{matrix}$	1.2	6	5	$\begin{matrix} 0 \\ -0.012 \end{matrix}$	4.2	2	100 150	200	879	1 180	2.6	3.5	$\begin{matrix} 3.2 \\ 19.3 \end{matrix}$	$\begin{matrix} 5.5 \\ 33.4 \end{matrix}$
MAGLT 5	LSAGLT 5					26											$\begin{matrix} 3.2 \\ 19.3 \end{matrix}$					$\begin{matrix} 5.5 \\ 33.4 \end{matrix}$	
MAG 6	LSAG 6	8.9	19	12	$\begin{matrix} 0 \\ -0.011 \end{matrix}$	21	12.4	2	$\begin{matrix} +0.014 \\ 0 \end{matrix}$	1.2	8	6	$\begin{matrix} 0 \\ -0.012 \end{matrix}$	5.2	2	150 200	300	711	855	2.5	3.0	$\begin{matrix} 1.7 \\ 11.7 \end{matrix}$	$\begin{matrix} 3.0 \\ 20.3 \end{matrix}$
MAGT 6	LSAGT 6					30											$\begin{matrix} 1.7 \\ 11.7 \end{matrix}$					$\begin{matrix} 3.0 \\ 20.3 \end{matrix}$	
MAGL 6	LSAGL 6	14.5	19	12	$\begin{matrix} 0 \\ -0.011 \end{matrix}$	30	21.4	2	$\begin{matrix} +0.014 \\ 0 \end{matrix}$	1.2	8	6	$\begin{matrix} 0 \\ -0.012 \end{matrix}$	5.2	2	150 200	300	1 030	1 500	3.6	5.2	$\begin{matrix} 5.0 \\ 27.6 \end{matrix}$	$\begin{matrix} 8.6 \\ 47.8 \end{matrix}$
MAGLT 6	LSAGLT 6					30											$\begin{matrix} 5.0 \\ 27.6 \end{matrix}$					$\begin{matrix} 8.6 \\ 47.8 \end{matrix}$	
MAG 8	LSAG 8	15.9	39	15	$\begin{matrix} 0 \\ -0.011 \end{matrix}$	25	14.6	2.5	$\begin{matrix} +0.014 \\ 0 \end{matrix}$	1.5	8.5	8	$\begin{matrix} 0 \\ -0.015 \end{matrix}$	7	3	150 200 250	500	1 190	1 330	5.5	6.2	$\begin{matrix} 3.3 \\ 22.0 \end{matrix}$	$\begin{matrix} 5.6 \\ 38.1 \end{matrix}$
MAGT 8	LSAGT 8					40											$\begin{matrix} 3.3 \\ 22.0 \end{matrix}$					$\begin{matrix} 5.6 \\ 38.1 \end{matrix}$	
MAGL 8	LSAGL 8	26.5	39	15	$\begin{matrix} 0 \\ -0.011 \end{matrix}$	37	26.6	2.5	$\begin{matrix} +0.014 \\ 0 \end{matrix}$	1.5	8.5	8	$\begin{matrix} 0 \\ -0.015 \end{matrix}$	7	3	150 200 250	500	1 800	2 470	8.4	11.5	$\begin{matrix} 10.3 \\ 56.3 \end{matrix}$	$\begin{matrix} 17.8 \\ 97.5 \end{matrix}$
MAGLT 8	LSAGLT 8					40											$\begin{matrix} 10.3 \\ 56.3 \end{matrix}$					$\begin{matrix} 17.8 \\ 97.5 \end{matrix}$	

- Notes ⁽¹⁾ No seal is included.
⁽²⁾ d_1 represents the maximum diameter for end machining.
⁽³⁾ Represents standard length. We can produce other than the standard length, please specify the length of spline shaft by indicating the length in mm with the identification number.
⁽⁴⁾ The direction of basic dynamic load rating (C), basic static load rating (C₀), dynamic torque rating (T), static torque rating and static moment rating (T₀, T_x, T_y) are shown in the sketches below.
 The upper values of T_x and T_y are for one external cylinder and the lower values are for two external cylinders inclose contact.

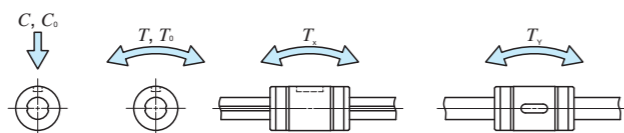

Example of identification number of assembled set

Model code Dimensions Part code Preload symbol Classification symbol Interchangeable code Supplemental code

MAG **L** **T** **5** **C2** **R150** **T1** **H** — **/N**

① ② ③ ④ ⑤ ⑥ ⑦ ⑧ ⑨ ⑩

① Model MAG Standard type LSAG Standard type	④ Size 2, 3, 4, 5, 6, 8	⑦ Preload amount To Clearance No symbol Standard T1 Light preload	⑩ Interchangeable No symbol Non-interchangeable specification S1 S1 specification S2 S2 specification
② Length of external cylinder No symbol Standard L Long	⑤ Number of external cylinders (2)	⑧ Accuracy class No symbol Ordinary H High P Precision	⑨ Special specification BS, N, OH, Q, RE, S, Y
③ Spline shaft shape No symbol Solid shaft T Hollow shaft	⑥ Length of spline shaft (150 mm)		

IKO C-Lube Linear Ball Spline MAG

Standard type															
Shape	MAG · LSAG														
Size	<table border="1"> <tr> <td>2</td><td>3</td><td>4</td><td>5</td><td>6</td><td>8</td><td>10</td> </tr> <tr> <td>12</td><td>15</td><td>20</td><td>25</td><td>30</td><td>40</td><td>50</td> </tr> </table>	2	3	4	5	6	8	10	12	15	20	25	30	40	50
2	3	4	5	6	8	10									
12	15	20	25	30	40	50									

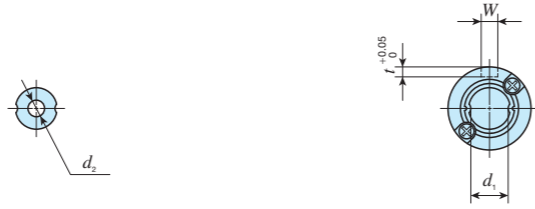

MAGT
Hollow shaft dimension for LSAG(L)T

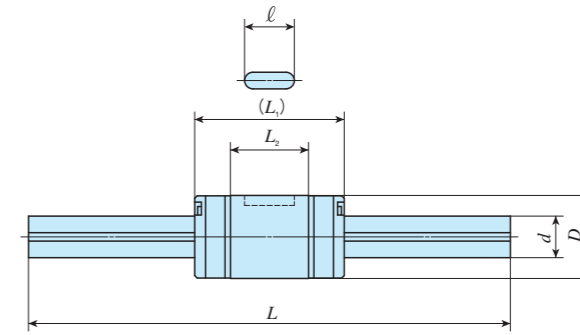

Identification number		Interchangeable	Mass (Ref.) g		External cylinder dimensions and tolerances mm								Spline shaft dimensions and tolerances mm					Basic dynamic load rating ⁽³⁾ C N	Basic static load rating ⁽³⁾ C ₀ N	Dynamic torque rating ⁽³⁾ T N · m	Static torque rating ⁽³⁾ T ₀ N · m	Static moment rating ⁽³⁾		
MAG series	LSAG series (No C-Lube)		External cylinder	Spline shaft (per 100 mm)	D	Dim. D tolerance	L ₁	L ₂	W	Dim. W tolerance	t	ℓ	d	Dim. d tolerance	d ₁ ⁽¹⁾	d ₂	L ⁽²⁾					Maximum length	T _x N · m	T _y N · m
MAG 10	LSAG 10	○	31.5	60.5	19	0 -0.013	30	18.2	3	+0.014 0	1.8	11	10	0 -0.015	8.9	-	200 300	600	1 880	2 150	10.9	12.5	7.0	12.1
MAGT 10	LSAGT 10	○		51			4	41.5								71.9								
-	LSAGL 10	○	56.5	60.5	19	0 -0.013	47	34.9	3	+0.014 0	1.8	11	10	0 -0.015	8.9	-	200 300	600	2 850	4 040	16.6	23.4	22.7	39.3
-	LSAGLT 10	○		51			4	115								200								
MAG 12	LSAG 12	○	44	87.5	21	0 -0.013	35	23	3	+0.014 0	1.8	15	12	0 -0.018	10.9	-	200 300 400	800	2 180	2 690	14.8	18.3	10.6	18.3
MAGT 12	LSAGT 12	○		66			6	59.1								102								
-	LSAGL 12	○	76.8	87.5	21	0 -0.013	54	42	3	+0.014 0	1.8	15	12	0 -0.018	10.9	-	200 300 400	800	3 220	4 850	21.9	33.0	32.2	55.7
-	LSAGLT 12	○		66			6	157								272								
-	LSAG 15	○	59.5	111	23	0 -0.013	40	27	3.5	+0.018 0	2	20	13.6	0 -0.018	11.6	-	200 300 400	1 000	4 180	6 070	31.3	45.6	27.8	33.2
-	LSAGL 15	○					110	-								112							181	
-	LSAG 20	○	130	202	30	0 -0.016	50	33	4	+0.018 0	2.5	26	18.2	0 -0.021	15.7	-	300 400 500	1 000	6 600	9 040	66.0	90.4	48.6	58.0
-	LSAGL 20	○					198	-								112							535	
-	LSAG 25	○	220	310	37	0 -0.016	60	39.2	5	+0.018 0	3	29	22.6	0 -0.021	19.4	-	300 400 500	1 200	11 200	14 300	139	178	92.8	111
-	LSAGL 25	○					336	-								273							420	
-	LSAG 30	○	430	450	45	0 -0.016	70	43	7	+0.022 0	4	35	27.2	0 -0.021	23.5	-	400 500 600	1 200	15 400	19 400	231	292	147	176
-	LSAGL 30	○					634	-								260							434	
-	LSAG 40	-	760	808	60	0 -0.019	100	70.8	10	+0.022 0	4.5	55	37.2	0 -0.025	33.5	-	400 500 600	1 200	21 300	31 600	426	632	364	434
-	LSAG 50	-					1 140	1 320								75							0 -0.019	100
-	LSAG 50	-	1 140	1 320	75	0 -0.019	100	66.4	15	+0.027 0	5	50	46.6	0 -0.025	42.0	-	400 500 600	1 200	28 300	36 100	707	904	389	464

- Notes ⁽¹⁾ d₁ represents the maximum diameter for end machining.
⁽²⁾ Represents standard length. We can produce other than the standard length, please specify the length of spline shaft by indicating the length in mm with the identification number.
⁽³⁾ The direction of basic dynamic load rating (C), basic static load rating (C₀), dynamic torque rating (T), static torque rating and static moment rating (T₀, T_x, T_y) are shown in the sketches below.
 The upper values of T_x and T_y are for one external cylinder and the lower values are for two external cylinders inclose contact.

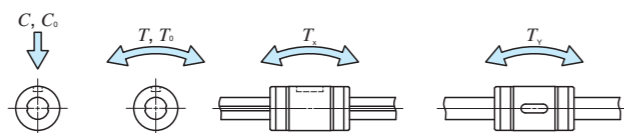

Example of identification number of assembled set

Model code: MAG, Dimensions: 12, Part code: C2, Preload symbol: R300, Classification symbol: T1, Interchangeable code: H, Supplemental code: /N

① Model MAG Standard type LSAG Standard type	④ Size 10, 12, 15, 20, 25, 30, 40, 50	⑦ Preload amount No symbol Standard T1 Light preload	⑩ Interchangeable No symbol Non-interchangeable specification S1 S1 specification S2 S2 specification
② Length of external cylinder No symbol Standard L Long	⑤ Number of external cylinders (2)	⑧ Accuracy class No symbol Ordinary H High P Precision	⑨ Special specification BS, N, OH, Q, RE, S, Y
③ Spline shaft shape No symbol Solid shaft T Hollow shaft	⑥ Length of spline shaft (300 mm)		

IKO C-Lube Linear Ball Spline MAG

Flange type															
MAGF · LSAGF															
Shape															
Size	<table border="1"> <tr> <td>2</td><td>3</td><td>4</td><td>5</td><td>6</td><td>8</td><td>10</td> </tr> <tr> <td>12</td><td>15</td><td>20</td><td>25</td><td>30</td><td>40</td><td></td> </tr> </table>	2	3	4	5	6	8	10	12	15	20	25	30	40	
2	3	4	5	6	8	10									
12	15	20	25	30	40										

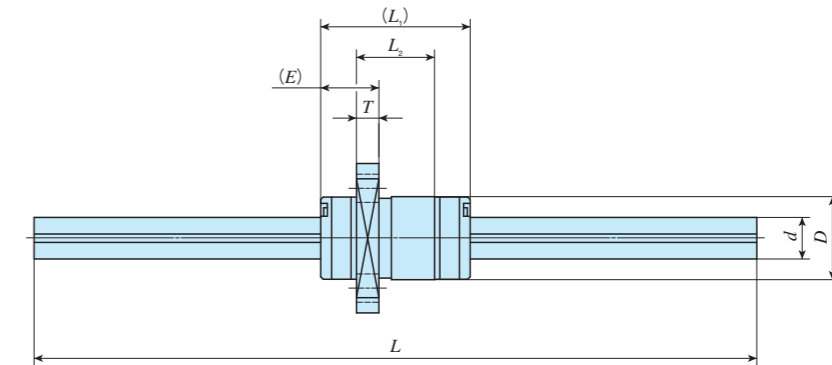
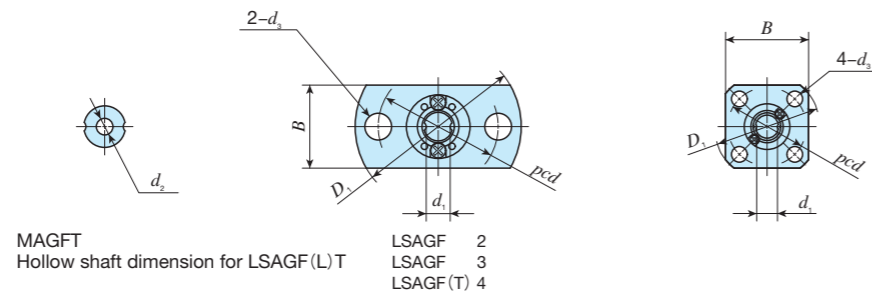

Identification number	Interchangeable	Mass (Ref.) g	External cylinder dimensions and tolerances mm												Spline shaft dimensions and tolerances mm					Basic dynamic load rating ⁽⁴⁾ C N	Basic static load rating ⁽⁴⁾ C ₀ N	Dynamic torque rating ⁽⁴⁾ T N · m	Static torque rating ⁽⁴⁾ T ₀ N · m	Static moment rating ⁽⁴⁾	
			External cylinder	Spline shaft (per 100 mm)	D	Dim. D tolerance	L ₁	L ₂	D ₁	B	E	T	pcd	d ₃	d	Dim. d tolerance	d ₁ ⁽²⁾	d ₂	L ⁽³⁾					Maximum length	T _x N · m
—	LSAGF 2 ⁽¹⁾	—	1.9	2.3	6	0 -0.008	8.5	4.7	15.5	8	3.4	1.5	11	2.4	—	—	50 100	100	222	237	0.28	0.30	0.22 1.4	0.39 2.4	
—	LSAGF 3 ⁽¹⁾	—	3.7	5.4	7	0 -0.009	10	5.9	18	9	4	1.9	13	2.9	—	—	100 150	150	251	285	0.45	0.51	0.31 1.9	0.53 3.3	
—	LSAGF 4 ⁽¹⁾	—	5.1	9.6	8	0 -0.009	12	7.9	21	10	4.6	2.5	15	3.4	—	—	100 150	200	303	380	0.70	0.87	0.52 2.9	0.90 5.0	
—	LSAGFT 4 ⁽¹⁾	8.2		1.5											150										
MAGF 5	LSAGF 5	○	8.9	14.9	10	0 -0.009	18	9.4	23	18	7	2.7	17	3.4	—	—	100 150	200	587	641	1.8	1.9	1.0 7.9	1.8 13.6	
MAGFT 5	LSAGFT 5	○		12.4											2										
—	LSAGFL 5	○	12	14.9	10	0 -0.009	26	16.9	23	18	7	2.7	17	3.4	—	—	100 150	200	879	1 180	2.6	3.5	3.2 19.3	5.5 33.4	
—	LSAGFLT 5	○		12.4											2										
MAGF 6	LSAGF 6	○	13.9	19	12	0 -0.011	21	12.4	25	20	7	2.7	19	3.4	—	—	150 200	300	711	855	2.5	3.0	1.7 11.7	3.0 20.3	
MAGFT 6	LSAGFT 6	○		16.5											2										
—	LSAGFL 6	○	19.5	19	12	0 -0.011	30	21.4	25	20	7	2.7	19	3.4	—	—	150 200	300	1 030	1 500	3.6	5.2	5.0 27.6	8.6 47.8	
—	LSAGFLT 6	○		16.5											2										
MAGF 8	LSAGF 8	○	23.5	39	15	0 -0.011	25	14.6	28	22	9	3.8	22	3.4	—	—	150 200 250	500	1 190	1 330	5.5	6.2	3.3 22.0	5.6 38.1	
MAGFT 8	LSAGFT 8	○		33											3										
—	LSAGFL 8	○	34.1	39	15	0 -0.011	37	26.6	28	22	9	3.8	22	3.4	—	—	150 200 250	500	1 800	2 470	8.4	11.5	10.3 56.3	17.8 97.5	
—	LSAGFLT 8	○		33											3										

- Notes (1) No seal is included.
 (2) d_1 represents the maximum diameter for end machining.
 (3) Represents standard length. We can produce other than the standard length, please specify the length of spline shaft by indicating the length in mm with the identification number.
 (4) The direction of basic dynamic load rating (C), basic static load rating (C₀), dynamic torque rating (T), static torque rating and static moment rating (T₀, T_x, T_y) are shown in the sketches below.
 The upper values of T_x and T_y are for one external cylinder and the lower values are for two external cylinders inclose contact.

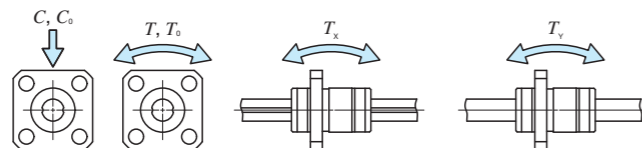

Example of identification number of assembled set

Model code Dimensions Part code Preload symbol Classification symbol Interchangeable code Supplemental code

MAGF **L** **T** **5** **C2** **R150** **T1** **H** — **/N**

① ② ③ ④ ⑤ ⑥ ⑦ ⑧ ⑨ ⑩

① Model MAGF Flange type LSAGF	④ Size 2, 3, 4, 5, 6, 8	⑦ Preload amount To Clearance No symbol Standard T1 Light preload	⑨ Interchangeable No symbol Non-interchangeable specification S1 S1 specification S2 S2 specification
② Length of external cylinder No symbol Standard L Long	⑤ Number of external cylinders (2)	⑧ Accuracy class No symbol Ordinary H High P Precision	⑩ Special specification BS, N, OH, Q, RE, S, Y
③ Spline shaft shape No symbol Solid shaft T Hollow shaft	⑥ Length of spline shaft (150 mm)		

IKO C-Lube Linear Ball Spline MAG

Flange type	
Shape	MAGF · LSAGF
Size	2 3 4 5 6 8 10 12 15 20 25 30 40

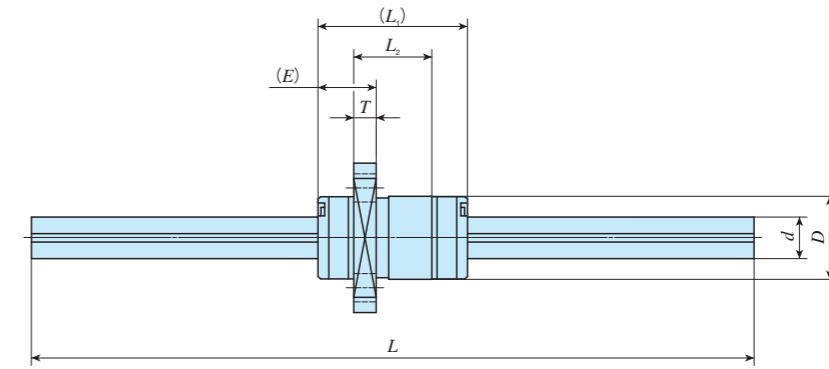
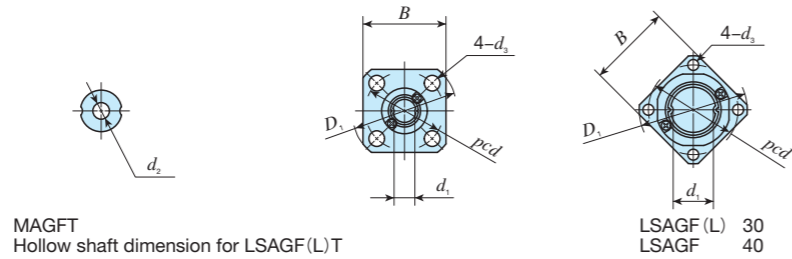

Identification number		Interchangeable	Mass (Ref.) g		External cylinder dimensions and tolerances mm									Spline shaft dimensions and tolerances mm					Basic dynamic load rating ⁽³⁾ C N	Basic static load rating ⁽³⁾ C ₀ N	Dynamic torque rating ⁽³⁾ T N·m	Static torque rating ⁽³⁾ T ₀ N·m	Static moment rating ⁽³⁾			
MAG series	LSAG series (No C-Lube)		External cylinder	Spline shaft (per 100 mm)	D	Dim. D tolerance	L ₁	L ₂	D ₁	B	E	T	pcd	d ₃	d	Dim. d tolerance	d ₁ ⁽¹⁾	d ₂					L ⁽²⁾	Maximum length	T _x N·m	T _y N·m
MAGF 10	LSAGF 10	○	45	60.5	19	0 -0.013	30	18.2	36	28	10	4.1	28	4.5	10	0 -0.015	8.9	-	200 300	600	1 880	2 150	10.9	12.5	7.0 41.5	12.1 71.9
MAGFT 10	LSAGFT 10	○		51			47	34.9										4								
-	LSAGFL 10	○	70.1	60.5	21	0 -0.013	35	23	38	30	10	4	30	4.5	12	0 -0.018	10.9	-	200 300 400	800	2 180	2 690	14.8	18.3	10.6 59.1	18.3 102
-	LSAGFLT 10	○		51			54	42										6								
MAGF 12	LSAGF 12	○	59	87.5	23	0 -0.013	40	27	40	31	11	4.5	32	4.5	13.6	0 -0.018	11.6	-	200 300 400	1 000	4 180	6 070	31.3	45.6	27.8 152	33.2 181
MAGFT 12	LSAGFT 12	○		66			65	52										4								
-	LSAGFL 12	○	91.8	87.5	30	0 -0.016	50	33	46	35	14	5.5	38	4.5	18.2	0 -0.021	15.7	-	300 400 500	1 000	6 600	9 040	66.0	90.4	48.6 288	58.0 343
-	LSAGFLT 12	○		66			71	54										4								
-	LSAGF 15	○	77	111	23	0 -0.013	60	39.2	57	43	17	6.6	47	5.5	22.6	0 -0.021	19.4	-	300 400 500	1 200	11 200	14 300	139	178	92.8 551	111 656
-	LSAGFL 15	○					128	84										63.2								
-	LSAGF 20	○	150	202	30	0 -0.016	70	43	65	50	21	7.5	54	6.6	27.2	0 -0.021	23.5	-	400 500 600	1 200	15 400	19 400	231	292	147 874	176 1 040
-	LSAGFL 20	○					218	71										54								
-	LSAGF 25	○	255	310	37	0 -0.016	98	71	65	50	21	7.5	54	6.6	27.2	0 -0.021	23.5	-	400 500 600	1 200	15 400	19 400	231	292	147 874	176 1 040
-	LSAGFL 25	○					371	71										54								
-	LSAGF 30	○	476	450	45	0 -0.016	98	71	65	50	21	7.5	54	6.6	27.2	0 -0.021	23.5	-	400 500 600	1 200	15 400	19 400	231	292	147 874	176 1 040
-	LSAGFL 30	○					680	71										54								
-	LSAGF 40	-	962	808	60	0 -0.019	100	70.8	93	73	26.6	12	73	9	37.2	0 -0.025	33.5	-	400 500 600	1 200	21 300	31 600	426	632	364 1 940	434 2 310

Notes (1) d_1 represents the maximum diameter for end machining.
 (2) Represents standard length. We can produce other than the standard length, please specify the length of spline shaft by indicating the length in mm with the identification number.
 (3) The direction of basic dynamic load rating (C), basic static load rating (C₀), dynamic torque rating (T), static torque rating and static moment rating (T₀, T_x, T_y) are shown in the sketches below.
 The upper values of T_x and T_y are for one external cylinder and the lower values are for two external cylinders in close contact.

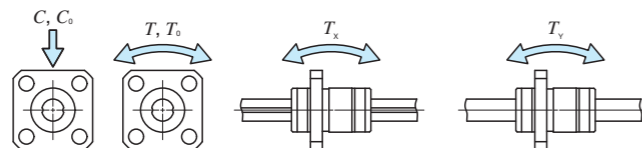

Example of identification number of assembled set

Model code: MAGF, Dimensions: T, Part code: 12, Preload symbol: C2, Classification symbol: R300, Interchangeable code: T1, Supplemental code: H, /N

① Model MAGF Flange type LSAGF	④ Size 10, 12, 15, 20, 25, 30, 40	⑦ Preload amount No symbol Standard T1 Light preload	⑩ Interchangeable No symbol Non-interchangeable specification S1 S1 specification S2 S2 specification
② Length of external cylinder No symbol Standard L Long	⑤ Number of external cylinders (2)	⑧ Accuracy class No symbol Ordinary H High P Precision	⑨ Special specification BS, N, OH, Q, RE, S, Y
③ Spline shaft shape No symbol Solid shaft T Hollow shaft	⑥ Length of spline shaft (300 mm)		

Block Type Linear Ball Spline

LSB

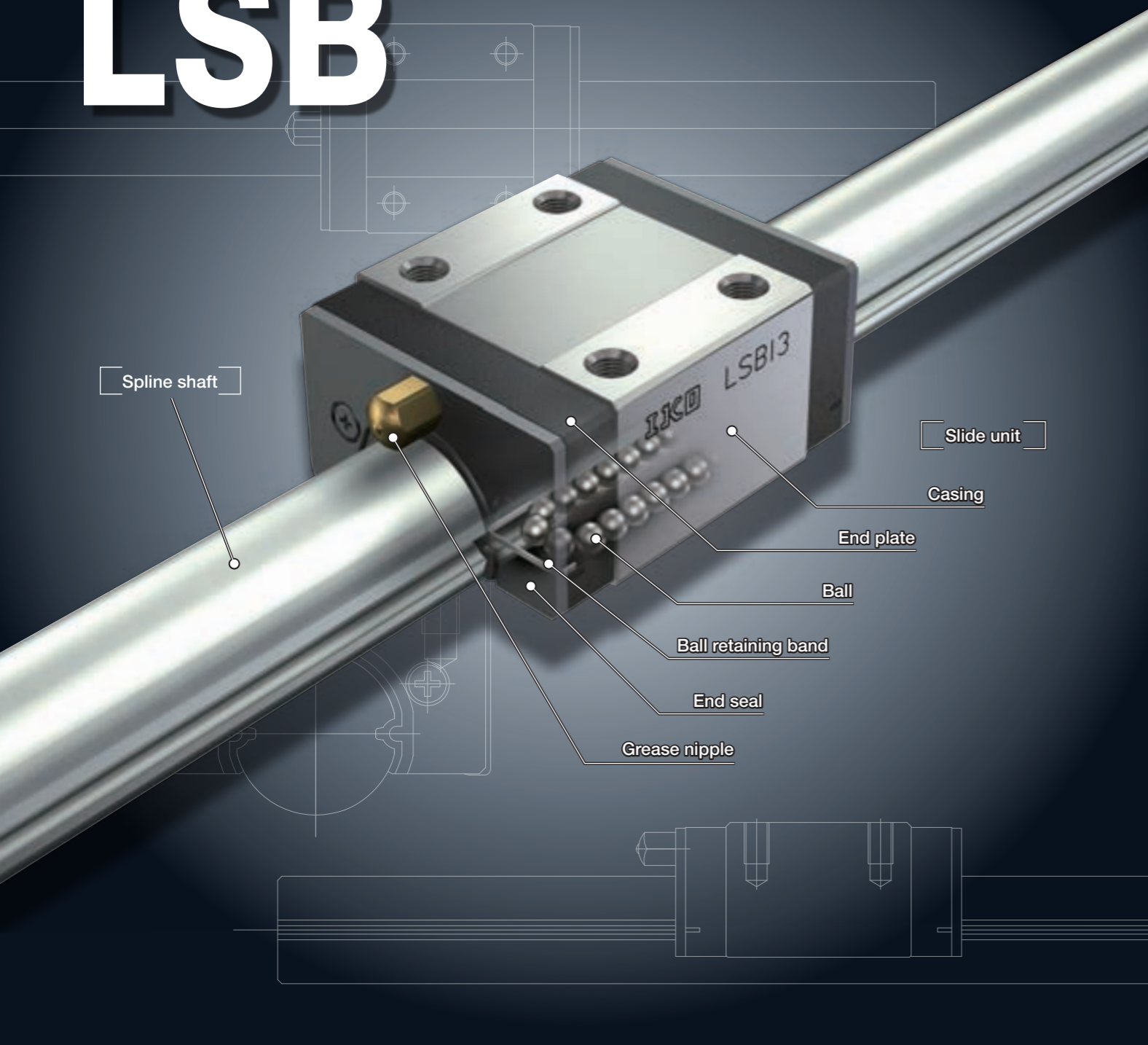

Points

1 Block type for easy mounting

The screw holes for mounting are provided on the slide unit, so that it can be easily mounted to the machine or device using bolts.

2 Stainless steel selections for excellent corrosion resistance

Products made of stainless steel are highly resistance to corrosion, so that they are suitable for applications where rust prevention oil is not preferred, such as in a cleanroom environment.

Identification Number and Specification

Example of an identification number

The specification of LSB series is indicated by the identification number. Indicate the identification number, consisting of a model code, dimensions, a part code, a material code, a preload symbol, a classification symbol, an interchangeable code, and a supplemental code for each specification to apply.

Interchangeable specification	1	2	3	4	5	6	7	8	9	10
Single slide unit	LSB	10	C1			SL	T ₁		S1	/U
Single spline shaft	LSB	10			R200	SL		H	S1	
Assembled set	LSB	10	C1		R200	SL	T ₁	H	S1	/U

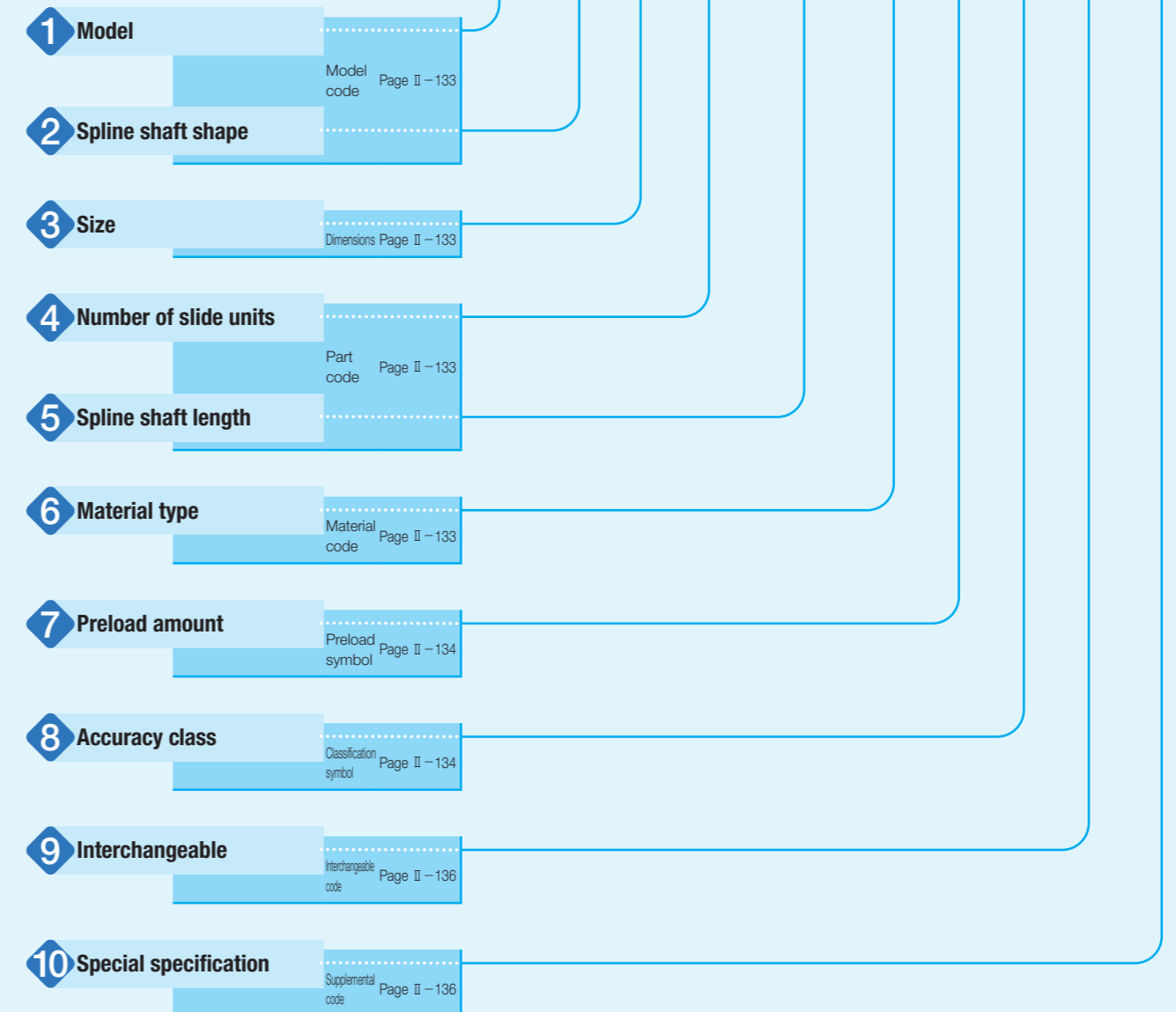



MAG · LSAG
LSB · LS

Identification Number and Specification – Model · Spline Shaft Shape · Size · Slide Unit ·

1 Model	Block Type Linear Ball Spline (LSB series) : LSB For applicable models and sizes, see Table 1.
2 Spline shaft shape	Solid shaft : No symbol Hollow shaft : T For applicable models and sizes, see Table 1.
3 Size	6, 8, 10, 13, 16, 20, 25 For applicable models and sizes, see Table 1.
4 Number of slide units	: C○ For an assembled set, indicates the number of slide units assembled on a spline shaft. For a single slide unit, only "C1" is specified.
5 Spline shaft length	: R○ The spline shaft length is indicated in mm. For standard and maximum lengths, see the dimension table.
6 Material type	High carbon steel made : No symbol Stainless steel made : SL For applicable models and sizes, see Table 1.

Table 1 Models and sizes of LSB series

Material	Shape	Model	Size						
			6	8	10	13	16	20	25
High carbon steel made	Solid shaft 	LSB	○ ⁽¹⁾	○ ⁽¹⁾	○ ⁽¹⁾	○	○	○	○
	Hollow shaft 	LSBT	○ ⁽¹⁾	○ ⁽¹⁾	○ ⁽¹⁾	○	○	○	○
Stainless steel made	Solid shaft 	LSB...SL	○	○	○	—	—	—	—

Note ⁽¹⁾ Slide units of size 6, 8, and 10 series are stainless steel-made only. When high carbon steel-made is specified for an assembled set, only the spline shaft will be high carbon steel-made.

Remark: The LSB series are all interchangeable specification. Non-interchangeable specification is not available.

Number of Slide Unit · Spline Shaft Length · Material Type · Preload Amount · Accuracy Class

7 Preload amount	Standard : No symbol Light preload : T ₁	Specify this item for an assembled set or a single slide unit. For details of the preload amount, see Table 2. For applicable preload types, see Table 3.
-------------------------	--	---

Table 2 Preload amount

Preload type	Item	Preload symbol	Preload amount N	Operational conditions
Standard	(No symbol)	(No symbol)	0 ⁽¹⁾	· Light and precise motion
Light preload	T ₁	T ₁	0.02 C ₀	· Almost no vibrations · Load is evenly balanced · Light and precise motion

Note ⁽¹⁾ Indicates zero or minimal amount of preload.

Remark: C₀ indicates the basic static load rating.

Table 3 Application of preload

Size	Preload type (preload symbol)	
	Standard (No symbol)	Light preload (T ₁)
6	○	—
8	○	○
10	○	○
13	○	○
16	○	○
20	○	○
25	○	○

8 Accuracy class	Ordinary : No symbol High : H	Specify this item for an assembled set or a single spline shaft. For details of accuracy class, see Fig. 1, Table 4 and Table 5.
-------------------------	----------------------------------	---

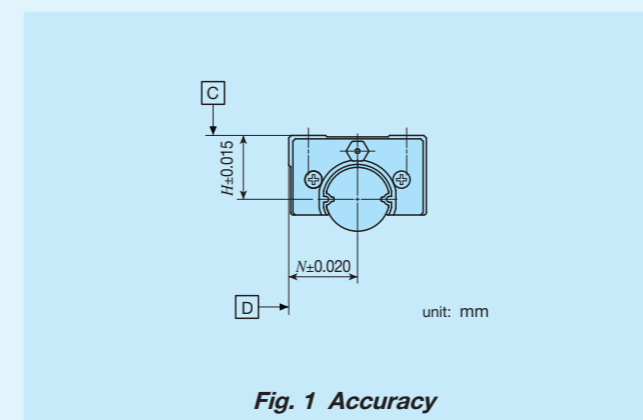

MAG · LSAG
LSB · LS

Table 4 Twist of grooves with respect to effective length of the spline part
unit: μm

Accuracy class	Ordinary (No symbol)	High (H)
Allowable value	33	13

Remark: The values can be applied to 100 mm of the effective length of the spline at any position.

Table 5 Allowable values of total radial runout of spline shaft axial line

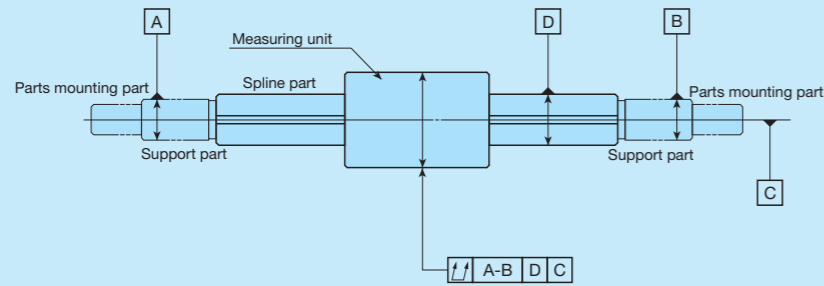

unit: μm

Size and accuracy class		Size							
		6, 8		10, 13		16, 20		25	
		Ordinary (No symbol)	High (H)	Ordinary (No symbol)	High (H)	Ordinary (No symbol)	High (H)	Ordinary (No symbol)	High (H)
Overall length of spline shaft mm									
—	200	72	46	59	36	56	34	53	32
200	315	133	89	83	54	71	45	58	39
315	400	185	126	103	68	83	53	70	44
400	500	236	163	123	82	95	62	78	50
500	630	—	—	151	102	112	75	88	57
630	800	—	—	190	130	137	92	103	68
800	1 000	—	—	—	—	170	115	124	83
1 000	1 250	—	—	—	—	—	—	151	102

Remark: Applied to all models of the same size.

Table 6 Measuring methods of accuracy

Item	Measuring method	Illustration of measuring method
Twist of grooves with respect to effective length of the spline part (see Table 4)	While supporting the spline shaft fixed, apply a unidirectional torsion moment load to the measuring unit, place the dial gage probe vertically to the spline shaft on the side face of the sunk key attached on the external cylinder, and measure the deflection when the external cylinder and the dial gage probe are moved 100 mm in the axial direction at any position on the effective length of the spline shaft. However, the dial gage probe should be applied as near as possible to the outer peripheral face of the external cylinder.	
Total radial runout of axial line of spline shaft (See Table 5)	While supporting the spline shaft at its support part or at both centers, place a dial gage probe on the outer peripheral face of the measuring unit and measure the deflection from one rotation of the spline shaft at several positions in the axial direction to obtain the maximum value.	

9 Interchangeable	S1 specification	: S1	Assemble a spline shaft and a slide unit with the same interchangeable code. Performance and accuracy of "S1" and "S2" are the same.
	S2 specification	: S2	

10 Special specification	/N, /U	For applicable special specifications, see Table 7.
---------------------------------	--------	---

Table 7 Application of special specifications (Single slide unit and assembled set)

Special specification	Supplemental code	Size							
		6	8	10	13	16	20	25	
No seal	/N	○	○	○	○	○	○	○	○
Under seal	/U	○	○	○	○	○	○	○	○

Remark: The combination of no seal (supplemental code/N) and under seal (supplemental code/U) is not available.

No seal /N

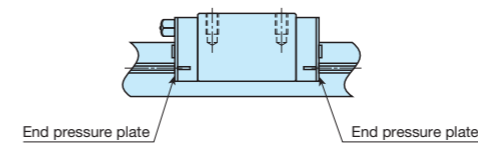

End seals at both ends of the slide unit can be replaced with end pressure plates, which do not come in contact with the spline shaft, to reduce frictional resistance. This specification is not effective for dust protection.

Under seal /U

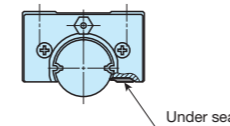

The seal is attached to the bottom of the slide unit to prevent foreign substances from entering from underneath.

Load Direction and Load Rating

The LSB series must be used with its load rating corrected in accordance to the load direction. The basic dynamic load rating and basic static load rating shown in the dimension table should be corrected to values in Table 8.

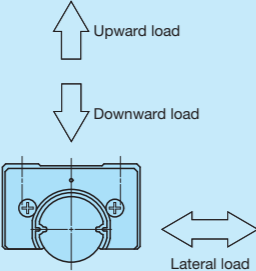

Table 8 Load ratings corrected for load direction



Size	Load rating and load direction		Basic dynamic load rating			Basic static load rating		
			Load direction			Load direction		
	Downward	Upward	Downward	Upward	Lateral	Downward	Upward	Lateral
6~20	C	C	0.84C	C ₀	C ₀	0.84C ₀	C ₀	C ₀
25	C	C	C	C ₀	C ₀	C ₀	C ₀	C ₀

Identification Number and Quantity for Ordering

To order an assembled set of LSB series, please specify the number of sets based on the number of spline shafts. For slide unit or single spline shafts, please specify the number of units.

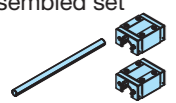
 (When 2 units are needed)	Example of identification number indication LSB 10 C1 T1 S○ /U Please specify S1 or S2. Only C1 can be specified.	Order quantity 2units
 (When 1 unit is needed)	Example of identification number indication LSB 10 R200 H S○ Please specify S1 or S2.	Order quantity 1unit
 (When 1 set is needed)	Example of identification number indication LSB 10 C2 R200 T1 H S○ /U Please specify S1 or S2.	Order quantity 1set

Moment of Inertia of Sectional Area and Section Coefficient of Spline Shaft

Table 9 Moment of inertia of sectional area and section coefficient of spline shaft

Identification number	Moment of inertia of sectional area mm ⁴		Section coefficient mm ³	
	Solid shaft	Hollow shaft	Solid shaft	Hollow shaft
6	55	54	19	19
8	170	170	44	43
10	440	420	90	87
13	1 220	1 160	190	180
16	2 830	2 630	360	340
20	7 110	6 620	730	680
25	17 600	15 100	1 440	1 230

Lubrication

Lithium-soap base grease (MULTEMP PS No.2 [KYODO YUSHI CO., LTD.]) is pre-packed in LSB series. The LSB series has grease nipple or oil hole as indicated in Table 10 and Table 11. For supply nozzle applicable to each grease nipple and dedicated supplying equipment (miniature greaser) applicable to oil holes, see Table 13 and Table 14.

Table 10 Parts for lubrication

Size	Grease nipple type	Applicable supply nozzle type
6, 8, 10	Oil hole	Miniature greaser
13, 16, 20	A-M3	A-5120V A-5240V
25	A-M4	B-5120V B-5240V

Table 11 Oil hole specifications

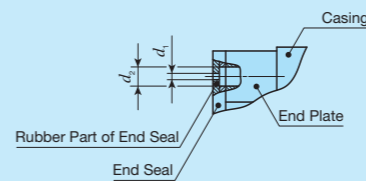

Size	d ₁	d ₂
6, 8	0.5	1.2
10	0.5	1.5

Table 12 Dimensions and shape of grease nipple

Model	Dimensions and shape
A-M3	
A-M4	

Table 13 Miniature greaser



Identification number	Grease name	Amount	Outside diameter of grease feed needle
MG10/MT2	MULTEMP PS No.2 [KYODO YUSHI CO., LTD.]	10ml	φ1mm
MG10/CG2	IKO Low Dust-Generation Grease for Clean Environment CG2		
MG2.5/EP2	Alvania EP Grease 2 [SHOWA SHELL SEKIYU K. K.]	2.5ml	
MG2.5/CG2	IKO Low Dust-Generation Grease for Clean Environment CG2		
MG2.5/CGL	IKO Low Dust-Generation Grease for Clean Environment CGL		
MG2.5/AF2	IKO Anti-Fretting Corrosion Grease AF2		

Table 14 Types and dimensions of supply nozzle

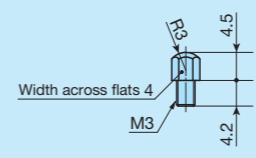
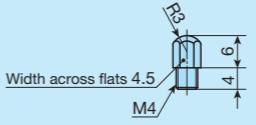
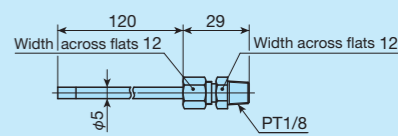
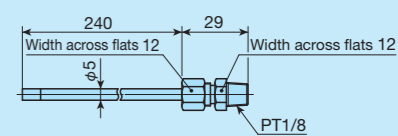
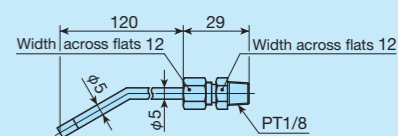
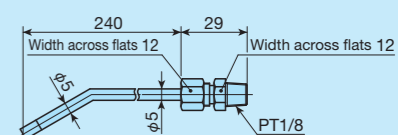
Model	Dimensions and shape
A-5120V	
A-5240V	
B-5120V	
B-5240V	

1N=0.102kgf=0.2248lbs.
1mm=0.03937inch

Dust Protection

The slide units of LSB series are equipped with end seals as standard for dust protection. However, if large amount of contaminant or dust are floating, or if large particles of foreign substances such as chips or sand may adhere to the spline shaft, it is recommended to attach a protective cover to the linear motion mechanism.

Precaution for Use

① Mounting surface, reference mounting surface and typical mounting structure

When mounting the LSB, properly align the reference mounting surface D of the slide unit with the reference mounting surface of the table and fix it. (See Fig. 2)

Outside diameter surface of the spline shaft, reference mounting surface D and mounting surface C are precisely ground. Machining the mounting surface of the table and bed, such as machine or device, to high accuracy and mounting them properly will ensure stable linear motion with high accuracy.

Reference mounting surface of the slide unit is the opposite side of the  mark. (See Fig. 3)

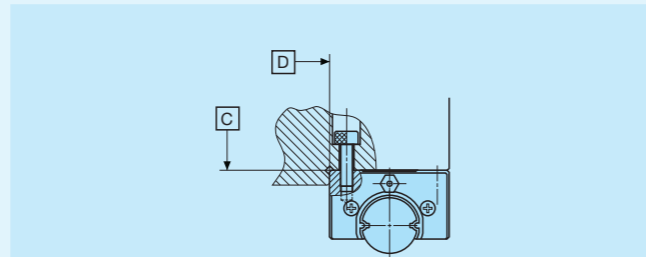

Fig. 2 Reference mounting surface and typical mounting structure

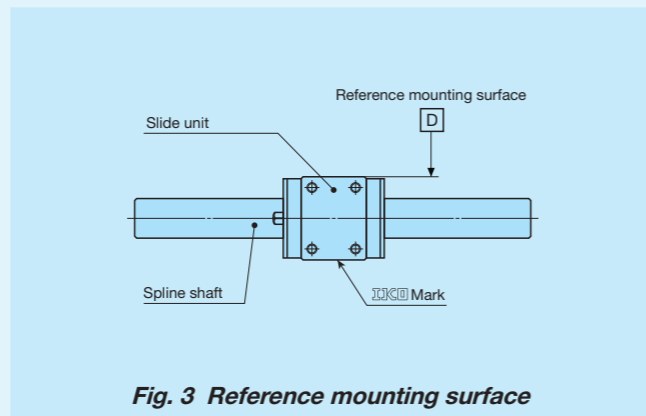

Fig. 3 Reference mounting surface

② Shoulder height of reference mounting surface

For the opposite corner of the mating reference mounting, it is recommended to have relieved fillet as indicated in Fig. 4. Recommended value for the shoulder height on the mating side is indicated in Table 15.

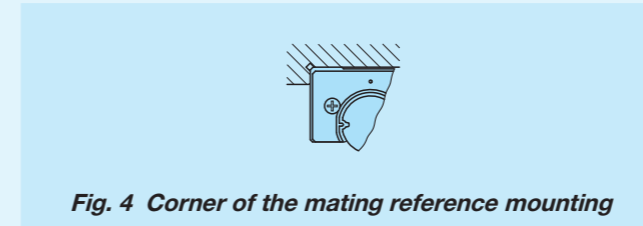

Fig. 4 Corner of the mating reference mounting

Table 15 Shoulder height

Size	Shoulder height
6	2
8	2.5
10	3
13	3.5
16	4
20	5
25	6

unit: mm

③ Additional machining of spline shaft end

The spline shaft is hardened by induction hardening. When additional machining on the shaft end is needed, make sure that the maximum diameter of the shaft end machining part does not exceed the dimension d_1 in the dimension table.

Spline shafts with special shaft end shapes can be prepared upon request. Contact **IKO** for further information.

④ Multiple slide units used in close proximity

When using multiple slide units in close proximity, greater load may be applied than the calculated value depending on the accuracy of the mounting surfaces and reference mounting surfaces of the machine or device. In such cases, allowance for greater applied load than the calculated value should be made.

In addition, special products with variation between H and N dimensions aligned can be prepared upon request. Contact **IKO** for further information.

⑤ Operating temperature

The maximum operating temperature is 120°C and temperature up to 100°C is allowed for continuous operation. When the temperature exceeds 100°C, contact **IKO**.

⑥ When mounting multiple assembled sets at the same time

Assemble a slide unit and a spline shaft with the same interchangeable code ("S1" or "S2").

⑦ Assembly of slide unit on spline shaft

When inserting a slide unit to the spline shaft, handle with care not to pry open the shaft and drop the balls.

⑧ Tightening torque for fixing screw

Typical tightening torque for mounting of the LSB series to the steel mating member material is indicated in Table 16. When vibration and shock of the machine or device are large, fluctuating load is large, or moment load is applied, fix it by using the torque 1.2 to 1.5 times larger than the value indicated in the table as necessary. If the mating member material is cast iron or aluminum alloy, reduce the tightening torque depending on the strength characteristics of the mating member material.

Table 16 Tightening torque for fixing screw

Bolt size	Tightening torque N · m	
	High carbon steel-made screw	Stainless steel-made screw
M2×0.4	0.50	0.31
M3×0.5	1.8	1.1
M4×0.7	4.1	—
M5×0.8	8.0	—
M6×1	13.6	—

Note (1) The tightening torque is calculated based on strength division 12.9 and property division A2-70.

IKO Block Type Linear Ball Spline

Shape							
Size	6	8	10	13	16	20	25

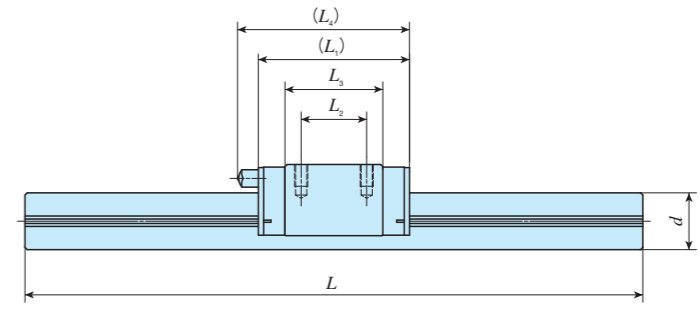
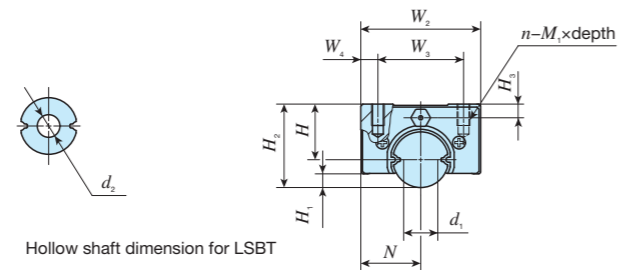

Identification number	Interchangeable	Mass (Ref.) g		Dimensions of assembly mm				Dimensions of slide unit mm							Spline shaft dimensions and tolerances mm					Basic dynamic load rating C N	Basic static load rating C ₀ N	Dynamic torque rating T N·m	Static torque rating T ₀ N·m	Static moment rating ⁽⁴⁾ N·m				
		Slide unit	Spline shaft (per 100 mm)	H	H ₁	H ₂	N	W ₂	W ₃	W ₄	L ₁	L ₂	L ₃	L ₄	n-M ₁ × depth	H ₃	d	Dim. d tolerance ⁽¹⁾	d ₁ ⁽²⁾					d ₂	L ⁽³⁾	Maximum length	T _x	T _y
LSB 6	○	7.6	21.2	6	1.1	9	6.5	13	8	2.5	20	—	12.5	—	2-M2 × 3	1.5	6	0 -0.012	3.7	2	150 200	300	675	1 090	2.0	3.3	2.3 13.6	1.9 11.4
LSBT 6	○		18.8																				540	875	1.6	2.6	1.8 10.9	1.5 9.1
LSB 6...SL	○	7.6	21.2	6	1.1	9	6.5	13	8	2.5	20	—	12.5	—	2-M2 × 3	1.5	6	0 -0.012	3.7	—	150 200	300	540	875	1.6	2.6	1.8 10.9	1.5 9.1
LSB 8	○	18	37.6	8	1.3	12	9	18	12	3	25	8	15.6	—	4-M3 × 3	1.5	8	0 -0.015	5	3	150 200 250	500	1 340	1 890	5.4	7.6	4.7 30.2	3.9 25.4
LSBT 8	○		32.1																			400	1 340	1 890	5.4	7.6	4.7 30.2	3.9 25.4
LSB 8...SL	○	18	37.6	8	1.3	12	9	18	12	3	25	8	15.6	—	4-M3 × 3	1.5	8	0 -0.015	5	—	150 200 250	500	1 070	1 510	4.3	6.1	3.7 24.2	3.1 20.3
LSB 10	○	34	59.7	10	1.9	15	10.5	21	15	3	31	10	21.2	—	4-M3 × 4	2.5	10	0 -0.015	6.9	4	200 300	600	1 810	2 760	9.1	13.8	9.1 53.0	7.6 44.5
LSBT 10	○		49.8																			1 450	2 200	7.3	11.0	7.3 42.4	6.1 35.6	
LSB 10...SL	○	34	59.7	10	1.9	15	10.5	21	15	3	31	10	21.2	—	4-M3 × 4	2.5	10	0 -0.015	6.9	—	200 300	600	1 450	2 200	7.3	11.0	7.3 42.4	6.1 35.6
LSB 13	○	62	100	13	3.2	19.5	14	28	20	4	35	15	22.4	40	4-M3 × 5	3.2	13	0 -0.018	9	6	200 300 400	800	3 330	4 290	21.7	27.9	15.4 96.3	12.9 80.8
LSBT 13	○		77.9																			800	3 330	4 290	21.7	27.9	15.4 96.3	12.9 80.8
LSB 16	○	112	152	16	4.2	24	16.5	33	25	4	43	20	28.8	48	4-M4 × 6	4	16	0 -0.018	11.4	8	200 300 400	1 000	4 980	6 490	39.9	51.9	29.7 176	24.9 148
LSBT 16	○		113																			1 000	4 980	6 490	39.9	51.9	29.7 176	24.9 148
LSB 20	○	215	240	20	5.8	30	20	40	30	5	53	25	37.3	58	4-M5 × 10	5	20	0 -0.021	15	10	300 400 500 600	1 000	6 670	9 080	66.7	90.8	52.7 299	44.2 251
LSBT 20	○		178																			1 000	6 670	9 080	66.7	90.8	52.7 299	44.2 251
LSB 25	○	403	376	25	6	37.5	26	52	40	6	67	30	41.8	70	4-M6 × 12	6	25	0 -0.021	19.3	15	300 400 500 600 800	1 200	10 500	13 400	136	175	95.6 566	95.6 566
LSBT 25	○		237																			1 200	10 500	13 400	136	175	95.6 566	95.6 566

Notes ⁽¹⁾ This does not apply to hollow shaft (LSBT).
⁽²⁾ d₁ represents the maximum diameter for end machining.
⁽³⁾ Represents standard length. We can produce other than the standard length, please specify the length of spline shaft by indicating the length in mm with the identification number.
⁽⁴⁾ The direction of basic dynamic load rating (C), basic static load rating (C₀), dynamic torque rating (T), static torque rating and static moment rating (T_x, T_y, T_v) are shown in the sketches below.
 The upper values of T_x and T_y are for one slide unit and the lower values are for two slide units in close contact.

Remarks 1. Block type Linear Ball Spline are all interchangeable specification.
 2. LSB 6, LSBT 6, LSB 6...SL, LSB 8, LSBT 8, LSB 8...SL, LSB 10, LSBT 10, and LSB 10...SL are provided with oil holes.
 The specifications of grease nipple and oil hole are shown in Table 11 and Table 12 on page II-138.

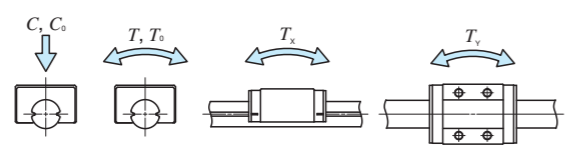

Example of identification number of assembled set

Model code	Dimensions	Part code	Material code	Preload symbol	Classification symbol	Interchangeable code	Supplemental code
LSB	10	C2	R300	SL	T1	H	S1 /N
①	②	③	④	⑤	⑥	⑦	⑧

① Model
LSB

② Spline shaft shape
No symbol: Solid shaft
T: Hollow shaft

③ Size
6, 8, 10, 13, 16, 20, 25

④ Number of external cylinders (2)

⑤ Length of spline shaft (300 mm)

⑥ Material type
No symbol: High carbon steel made
SL: Stainless steel made

⑦ Preload amount
No symbol: Standard
T1: Light preload

⑧ Accuracy class
No symbol: Ordinary
H: High

⑨ Interchangeable
S1: S1 specification
S2: S2 specification

⑩ Special specification
N, U

MAG · LSAG
LSB · LS

Stroke Ball Spline

LS

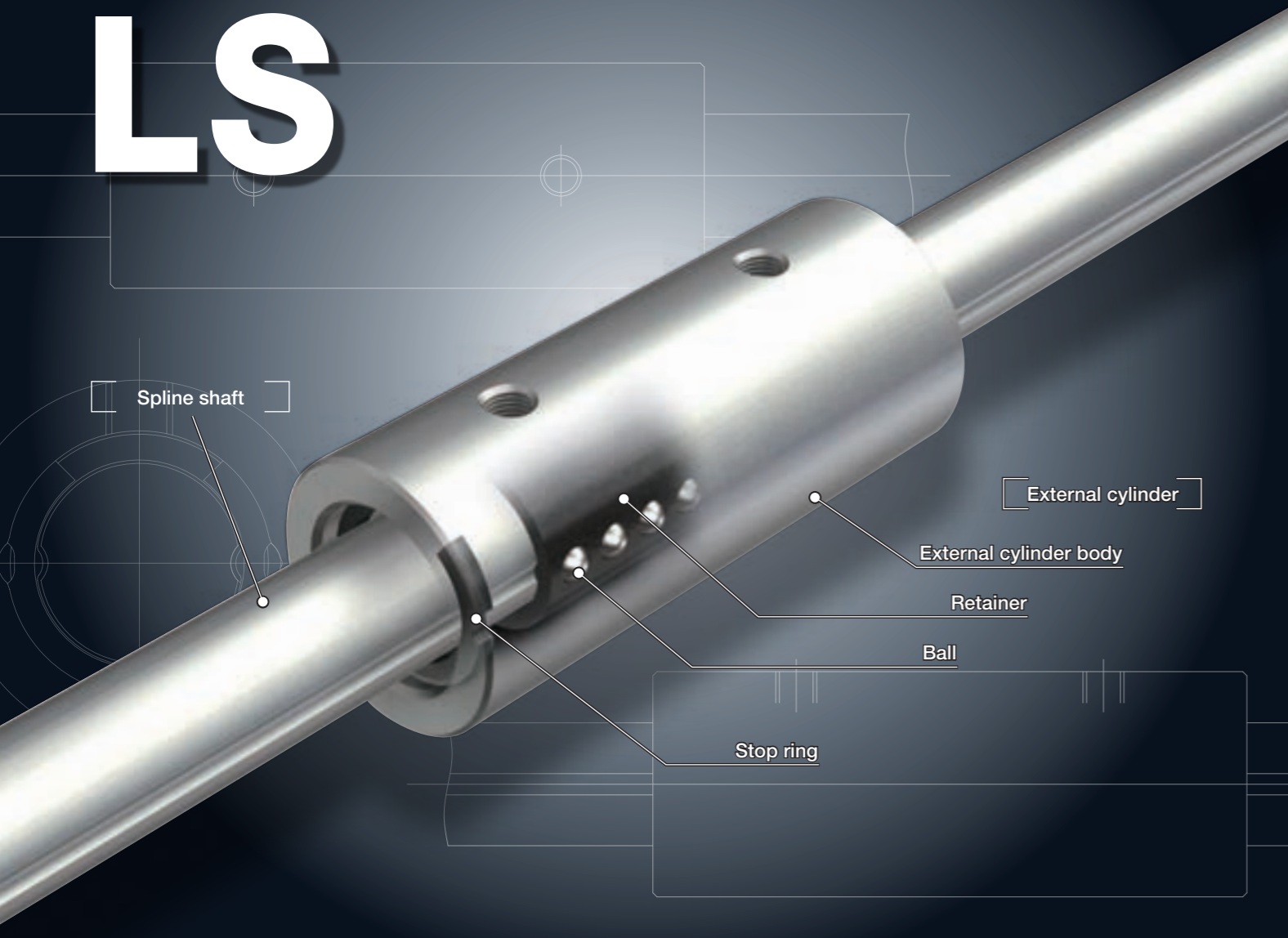

Points

1 Achieved extremely smooth motion

By building the high accuracy retainer into the limited stroke type with small recirculation resistance of the balls, a light and smooth motion with extremely small fluctuation of frictional resistance even in vertical shaft use has been achieved.

2 Best for nozzle part for chip mounter

Since it exhibits a stable and high positioning accuracy for stroke direction, it is best for the uses of vertical shaft and high-tact operations such as chip mounter.

3 Supports special shapes

We manufacture special shapes to meet the customer's uses such as end machining and external cylinder with holders. Please ask **IKO** for your needs.

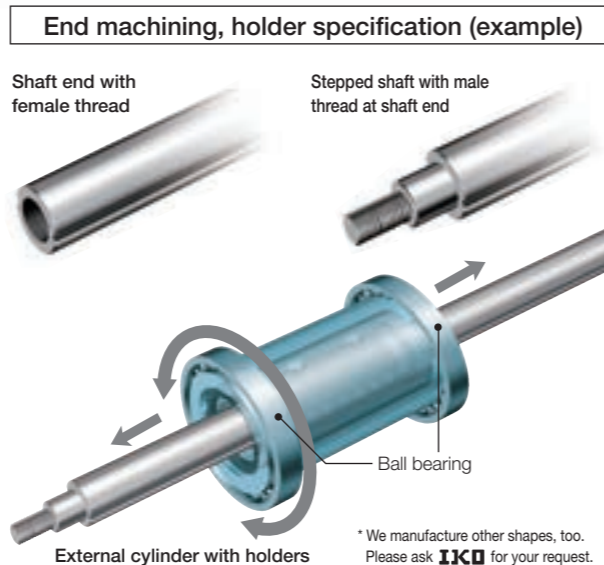

Identification Number and Specification

Example of an identification number

The specification of LS series is indicated by the identification number. Indicate the identification number, consisting of a model code, dimensions, a part code, a preload symbol, a classification symbol, and a supplemental code for each specification to apply.

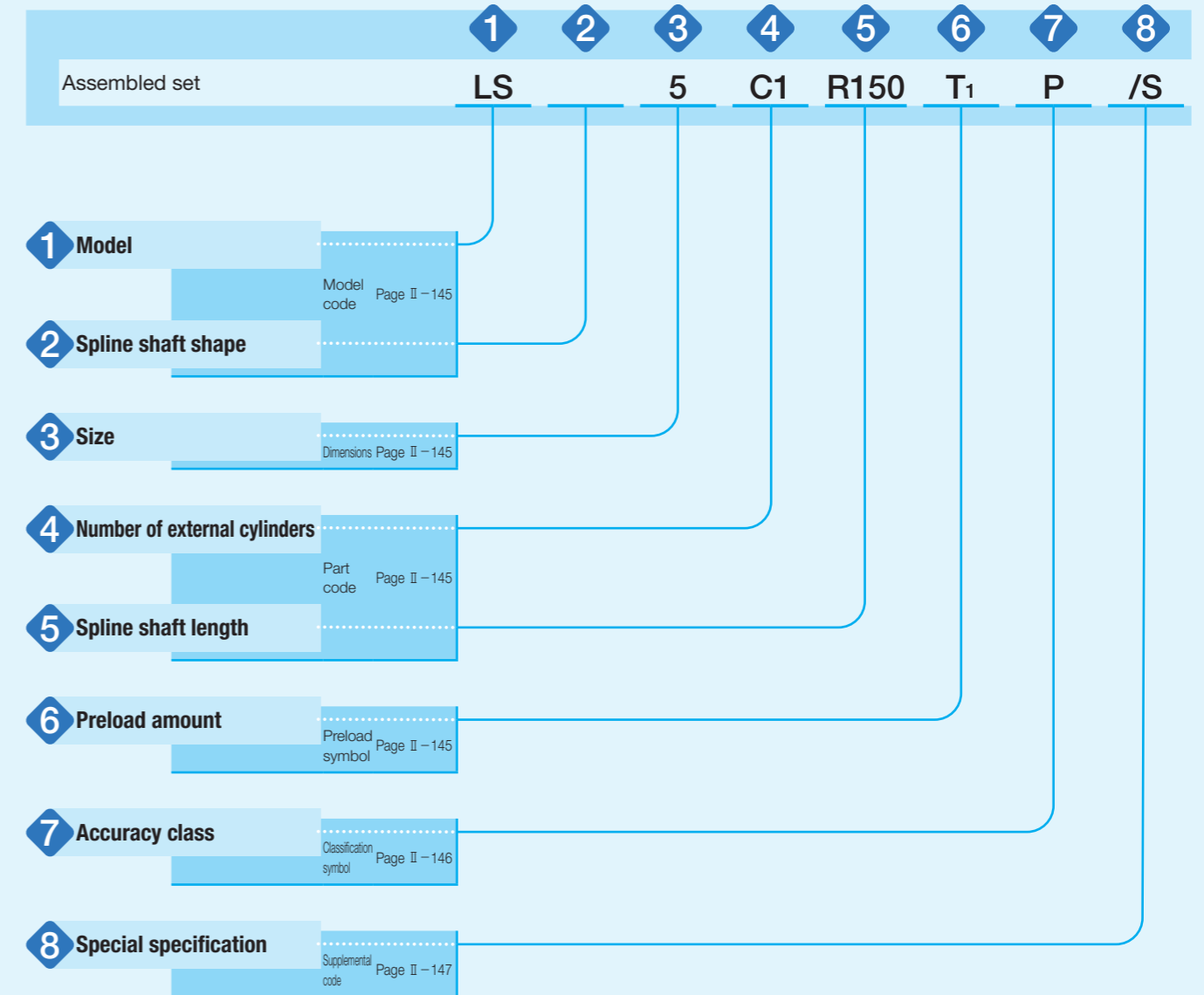

MAG · LSAG
LSB · LS

Identification Number and Specification — Model · Spline Shaft Shape ·

1 Model	Stroke Ball Spline (LS series)	: LS	For applicable models and sizes, see Table 1.
2 Spline shaft shape	Solid shaft	: No symbol	For applicable models and sizes, see Table 1.
	Hollow shaft	: T	
3 Size	4, 5, 6		For applicable models and sizes, see Table 1.

Table 1 Models and sizes of LS series

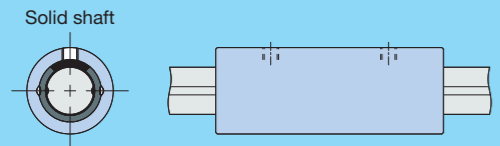
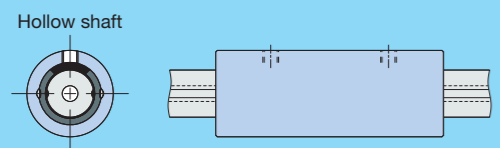
Shape	Model	Size		
		4	5	6
 Solid shaft	LS	○	○	○
 Hollow shaft	LST	○	○	○

4 Number of external cylinders		: C1	For the number of external cylinders assembled on a spline shaft, only one unit (C1) can be specified.
5 Spline shaft length		: RO	The spline shaft length is indicated in mm. For standard and maximum lengths, see the dimension table.
6 Preload amount	Light preload	: T ₁	For preload amount, only light preload (T ₁) can be specified. For details of the preload amount, see Table 2.

Table 2 Preload amount

Item	Preload symbol	Preload amount N	Operational conditions
Preload type			
Light preload	T ₁	0.02C ₀	<ul style="list-style-type: none"> · Almost no vibrations · Load is evenly balanced · Light and precise motion

Remark: C₀ indicates the basic static load rating.

Size · Number of External Cylinders · Spline Shaft Length · Preload Amount · Accuracy Class—

7 Accuracy class	Precision	: P	For accuracy class, only precision (P) can be specified. For details of accuracy class, see Table 3, Table 4 and Table 5.
-------------------------	-----------	-----	---

Table 3 Allowable value of each part

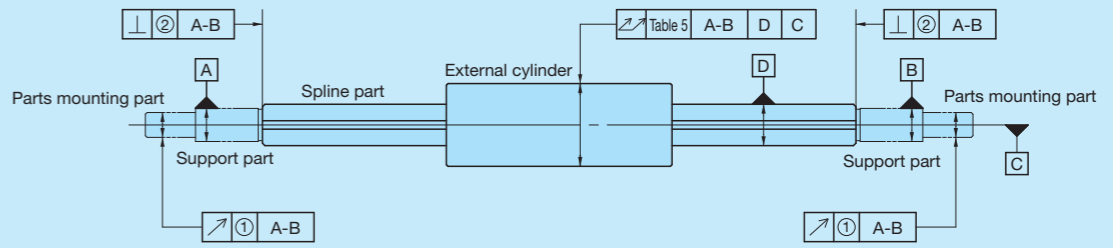

Size	Relative to axial line of supporting part of spline shaft	
	① Radial runout of periphery of parts mounting part (1)	② Perpendicularity of spline part end face (1)
	Precision (P)	Precision (P)
4	8	6
5		
6		

unit: μm

Note (1) The values are for the processed shaft ends.

Table 4 Twist of grooves with respect to effective length of the spline part

Accuracy class	Precision (P)
Allowable value	6

unit: μm

Remark: The values can be applied to 100 mm of the effective length of the spline at any position.

Table 5 Allowable values of total radial runout of spline shaft axial line

Total spline shaft length mm	Precision (P)	
	Over	Incl.
—	200	26
200	300	57

unit: μm

Table 6 Measuring methods of accuracy

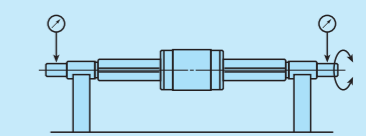
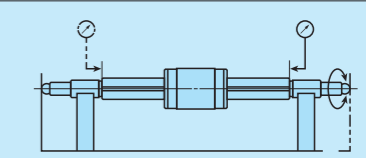
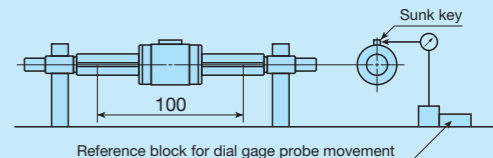
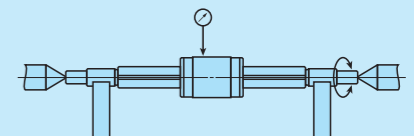
Item	Measuring method	Illustration of measuring method
(1) Radial runout of periphery of parts mounting part with respect to axial line of supporting part of spline shaft (see Table 3①)	While supporting the spline shaft at its support part, place the dial gage probes on the outer peripheral faces of the parts mounting part and measure the deflection from one rotation of the spline shaft.	
(1) Perpendicularity of spline part end face with respect to axial line of supporting part of spline shaft (see Table 3②)	While supporting the spline shaft at its support part and one spline shaft end, place the dial gage probes on the spline end faces and obtain perpendicularity by measuring the deflection from one rotation of the spline shaft.	
Twist of grooves with respect to effective length of the spline part (See Table 4)	While supporting the spline shaft fixed, apply a unidirectional torsion moment load to the measuring unit, place the dial gage probe vertically to the spline shaft on the side face of the sunk key attached on the external cylinder, and measure the deflection when the external cylinder and the dial gage probe are moved 100 mm in the axial direction at any position on the effective length of the spline shaft. However, the dial gage probe should be applied as near as possible to the outer peripheral face of the external cylinder.	
Total radial runout of axial line of spline shaft (See Table 5)	While supporting the spline shaft at its support part or at both centers, place a dial gage probe on the outer peripheral face of the external cylinder and measure the deflection from one rotation of the spline shaft at several positions in the axial direction to obtain the maximum value.	

Note (1) The accuracy are for the processed shaft ends.

8 Special specification Stainless steel spline shaft /S Applicable to the solid shaft of size 5 and 6.

Stainless steel spline shaft /S

The material of the solid spline shaft is changed to stainless steel. The load rating will change to a value obtained by multiplying the load rating for the steel spline shaft by a factor of 0.8.

Allowable Load

Allowable load refers to load of smooth rolling motion on contact surface to which maximum contact stress is applied and the sum of whose elastic deformation of rolling elements and raceway is small.

Therefore, use applied load within the allowable load range if very smooth rolling motion and high accuracy are required.

Load Direction and Load Rating

The LS series must be used with its load rating corrected in accordance to the load direction. The basic dynamic load rating and basic static load rating shown in the dimension table should be corrected to values in Table 7.

Table 7 Load ratings corrected for load direction

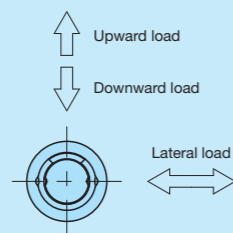

Size	Load rating and load direction	Basic dynamic load rating			Basic static load rating		
		Load direction			Load direction		
		Downward	Upward	Lateral	Downward	Upward	Lateral
4, 5, 6		C	C	1.47C	C ₀	C ₀	1.73C ₀

Moment of Inertia of Sectional Area and Section Coefficient of Spline Shaft

Table 8 Moment of inertia of sectional area and section coefficient of spline shaft

Size	Moment of inertia of sectional area mm ⁴		Section coefficient mm ³	
	Solid shaft	Hollow shaft	Solid shaft	Hollow shaft
4	12	12	6	6
5	29	29	12	12
6	61	61	21	21

Lubrication

Grease is not pre-packed in the LS series, so please perform adequate lubrication as needed.

Upon delivery, anti-rust oil is applied. Therefore, perform cleaning with clean solution before mounting and apply high-quality lubrication oil or grease before use. For grease lubrication, use of high-quality lithium-soap base grease is recommended.

Since no grease nipple or oil hole is provided, apply grease directly to the raceway part of the spline shaft when supplying the grease.

Precaution for Use

1 Fitting of external cylinder

Generally, transition fit (J7) is used for fitting between the external cylinder and the housing bore. When high accuracy and high rigidity are not required, clearance fit (H7) can also be used.

2 Typical mounting structure

Mounting examples of the external cylinder are shown in Fig. 1. The rotation detent for external ring should be mounted using the screw hole provided on the external cylinder. The fixing thread depth must not exceed the maximum fixing thread depth indicated in the dimension table. Since the screw hole for the external cylinder is penetrated, the spline shaft or retainer will be pushed by the screw if the fixing thread depth is too deep, and the running accuracy and life will be adversely affected.

Since there is no built-in mechanical stopper to regulate linear motion, install a stopper mechanism in proximity if risk of overstroke exists.

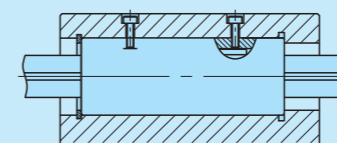

Fig. 1 Mounting example

3 Handling upon operation

Stroke should be used within the effective stroke range shown in the dimension table.

The retainer may be deviated from the right position due to offset load or irregular and high-velocity motion, etc. Fully stroke it once in certain operating time or certain number of reciprocating motion to correct the retainer position.

4 Additional machining of spline shaft end

The spline shaft is hardened by induction hardening. When additional machining on the shaft end is needed, make sure that the maximum diameter of the shaft end machining part does not exceed the dimension *d*₁ in the dimension table. Spline shafts with special shaft end shapes can be prepared upon request. Contact **IKO** for further information.

5 Operating temperature

The maximum operating temperature for LS series is 120°C and temperature up to 100°C is allowed for continuous operation. When the temperature exceeds 100°C, contact **IKO**.

Dust Protection

No dust protection seal is provided for LS series. For applications in other than clean environment, cover the entire unit with a protective case, etc. to prevent harmful foreign substances such as dust and particles from outside from entering.

6 Assembly of external cylinder on spline shaft

When assembling the external cylinder on the spline shaft, correctly fit the grooves of the external cylinder and the spline shaft and move the external cylinder softly in parallel direction. Rough handling may result in dropping of steel balls. After assembling, correct the position of the retainer to be in the center of the external cylinder. After assembling the external cylinder to the housing, insert the shaft softly. Move the retainer as well as the shaft until they contact one side of the surface and stop. Then push the shaft softly not to damage balls or raceway to the position a half of the maximum stroke length and return it by the same length (a half of the maximum stroke) so that the retainer is positioned regularly at the center of the external cylinder.

The products are already adjusted so as to provide the best accuracy when the marks of the external cylinder and the spline shaft face the same direction. Be careful not to change the assembly direction. (See Fig. 2)



Fig. 2 Mounting direction of external cylinder

7 Mounting of external cylinder

When press-fitting the external cylinder to the housing, assemble them correctly by using a press and a suitable jig fixture. (See Fig. 3)

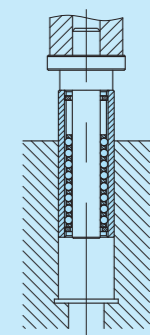
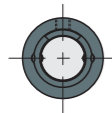
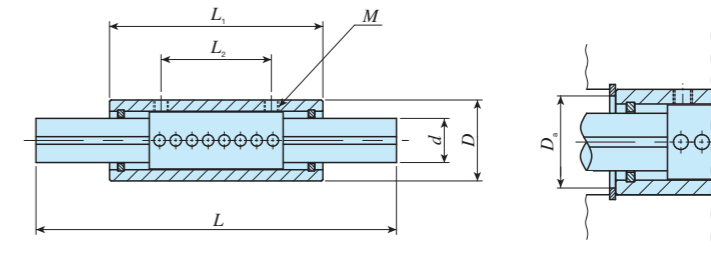
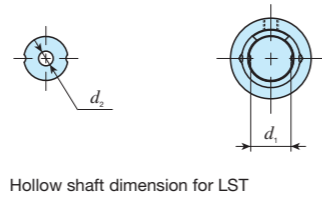

Fig. 3 Press-fitting of external cylinder

IKO Stroke Ball Spline

Shape	LS 		
	4	5	6



Identification number	Interchangeable	Mass (Ref.) g		External cylinder dimensions and tolerances mm						Spline shaft dimensions and tolerances mm					Effective stroke length mm	Maximum stroke length mm	Mounting Maximum dimensions D_a mm	Basic dynamic load rating C N	Basic static load rating C_0 N	Allowable load F N ⁽³⁾	Dynamic torque rating T N·m ⁽³⁾	Static torque rating T_0 N·m ⁽³⁾	Static moment rating T_x, T_y N·m ⁽³⁾		
		External cylinder	Spline shaft (per 100 mm)	D	Dim. D tolerance	L_1	L_2	M	Maximum fixing thread depth	d	Dim. d tolerance	d_1 ⁽¹⁾	d_2	L ⁽²⁾									Maximum length	T_x	T_y
LS 4	—	5.7	9.6	8	0 -0.009	24	10	M2	1.3	4	0 -0.012	3.2	—	100 150	200	10	13.2	5	285	380	127	0.66	0.87	0.88	1.5
LST 4	—		8.6												1.5										
LS 5	—	8.9	14.9	10	0 -0.009	27	12	M2	1.4	5	0 -0.012	4.2	—	100 150	200	10	14	7	616	748	249	1.8	2.2	2.0	3.5
LST 5	—		12.4												2										
LS 6	—	10.9	19	11	0 -0.011	29	15	M2	1.4	6	0 -0.012	5.2	—	150 200	300	10	13.6	8	673	855	285	2.4	3.0	2.6	4.4
LST 6	—		16.5												2										

Notes ⁽¹⁾ d_1 represents the maximum diameter for end machining.

⁽²⁾ Represents standard length. We can produce other than the standard length, please specify the length of spline shaft by indicating the length in mm with the identification number.

⁽³⁾ The direction of basic dynamic load rating (C), basic static load rating (C_0), allowable load (F), dynamic torque rating (T), static torque rating and static moment rating (T_0, T_x, T_y) are shown in the sketches below.

Remark: Grease is not pre-packed, so please perform adequate lubrication as needed.

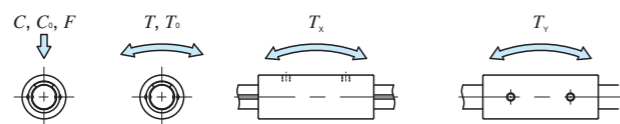

Example of identification number of assembled set

Model code	Dimensions	Part code	Preload symbol	Classification symbol	Supplemental code
LS	5	C1 R150	T1	P	/S
①	②	③	④	⑤	⑥
① Model	② Spline shaft shape	③ Size	④ Number of external cylinders (1)	⑤ Length of spline shaft (150 mm)	⑥ Preload amount
LS	No symbol Solid shaft T Hollow shaft	4, 5, 6	1	150	T1 Light preload
				⑦ Accuracy class	⑧ Special specification
				P Precision	S

Linear Bushing

Linear Bushing G

Linear Bushing

Miniature Linear Bushing



Linear Bushing G

LMG



Points

1 High load capacity

The structure that balls in two rows have contact with the track groove of the shaft allows greater rigidity and larger load capacity.

2 Solid shaft and hollow shaft

There are two types of shafts with grooved raceway: a solid shaft and a hollow shaft. The hollow shaft is useful for piping, wiring, air removal, etc.

3 Dimensionally compatible with Linear Bushing LM

LMG series are dimensionally compatible with Linear Bushing LM to allow easy replacement.

Identification Number and Specification

Example of an identification number

The specification of LMG series is indicated by the identification number. Indicate the identification number, consisting of a model code, dimensions, a part code, and a supplemental code for each specification to apply.

Interchangeable specification	1	2	3	4	5	6
Single external cylinder	LMG		10	C1		/U
Single shaft with grooved raceway	LMG	T	10		R300	
Assembled set	LMG	T	10	C1	R300	/U

- 1 Model Model code Page II - 155
- 2 Shape of shaft with grooved raceway Part code Page II - 155
- 3 Size Dimensions Page II - 155
- 4 Number of external cylinders Part code Page II - 155
- 5 Length of shaft with grooved raceway Part code Page II - 155
- 6 Special specification Supplemental code Page II - 155

Identification Number and Specification – Model · Shape of Shaft · Size · Number of External Cylinders · Length of Shaft · Special Specification –

1 Model	Linear Bushing G (LMG series) For applicable models and sizes, see Table 1.	: LMG
2 Shape of shaft with grooved raceway	Solid shaft : No symbol Hollow shaft : T	For applicable models and sizes, see Table 1.
3 Size	6, 8, 10, 13, 16, 20	Indicate the shaft diameter in mm. For applicable models and sizes, see Table 1.

Table 1 Models and sizes of LMG series

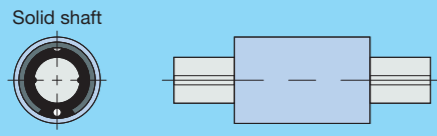
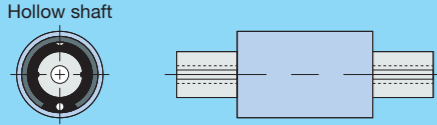
Shape	Model	Size					
		6	8	10	13	16	20
Solid shaft 	LMG	○	○	○	○	○	○
Hollow shaft 	LMGT	○	○	○	○	○	○

Remark: LMG series are all interchangeable specification. Non-interchangeable specification is not available.

4 Number of external cylinders	: ○○	For an assembled set, indicates the number of external cylinders assembled on a shaft with grooved raceway. For a single external cylinder, only "C1" is specified.
5 Length of shaft with grooved raceway	: R○	Indicate the length of the shaft with grooved raceway in mm. For standard and maximum lengths, see the dimension table.
6 Special specification	With end seal /U	Applicable to all models and sizes.

With end seal /U

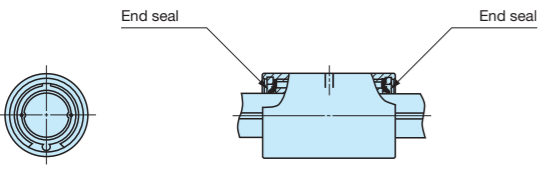

End seals are attached to both ends of the external cylinder to prevent foreign substances from entering.

Accuracy

Table 2 Twist of grooves with respect to effective length of track groove

Allowable value	33
-----------------	----

unit: μm

Remark: The values can be applied to 100 mm of the effective length of the track groove part at any position.

Table 3 Allowable values of total radial runout of shaft with grooved raceway axial line

Overall length of shaft with grooved raceway mm	Size	Size				
		6	8	10	13	16, 20
Over	Incl.					
–	200	142	142	129	129	126
200	315	203	203	153	153	141
315	400	–	255	173	173	153
400	500	–	306	193	193	165
500	630	–	–	221	221	182
630	800	–	–	–	260	207
800	1 000	–	–	–	–	240

Remark: These are values when an internal clearance is 0 μm .

Table 4 Measuring methods of accuracy

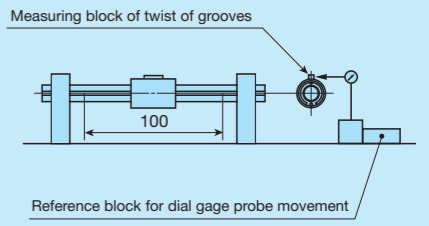
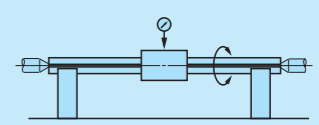
Item	Measuring method	Illustration of measuring method
Twist of grooves with respect to effective length of track groove (See Table 2)	While supporting the shaft with grooved raceway, apply a unidirectional torsion moment load to the external cylinder, place the dial gage probe vertically to the shaft with grooved raceway on the side face of the measuring block of twist of grooves attached on the external cylinder, and measure the deflection when the external cylinder and the dial gage probe are moved 100 mm in the axial direction at any position on the effective length of track groove of the shaft with grooved raceway. However, the dial gage probe should be applied as near as possible to the outer peripheral face of the external cylinder.	
Total radial runout of axial line of shaft with grooved raceway (See Table 3)	While supporting the shaft with grooved raceway at its supporting parts or at both centers, place a dial gage probe on the outer peripheral face of the external cylinder, and measure the deflection from one rotation of the shaft with grooved raceway at several positions in the axial direction to obtain the maximum value.	

Internal Clearance

The internal clearance of LMG series is approximately 10 μm .

LMG · LM · LMS

Load Direction and Load Rating

The LMG series must be used with its load rating corrected in accordance to the load direction. The basic dynamic load rating and basic static load rating shown in the dimension table should be corrected to values in Table 4.

Table 4 Load ratings corrected for load direction

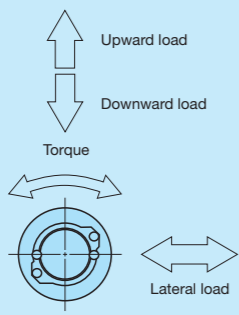

Size	Basic dynamic load rating			Basic static load rating		
	Load direction			Load direction		
	Downward	Upward	Lateral	Downward	Upward	Lateral
6~20	C	C	1.43C	C_0	C_0	1.73 C_0

Identification number and quantity for ordering

To order an assembled set of LMG series, please specify the number of sets based on the number of shafts with grooved raceway. For external cylinders or single shafts with grooved raceway, please specify the number of units.

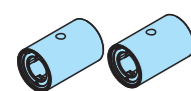
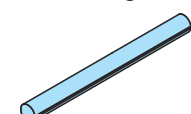
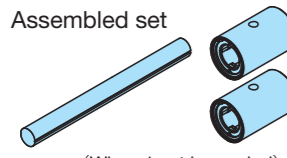
 (When 2 pieces are needed)	Example of identification number indication LMG 10 C1 /U Only C1 can be specified.	Order quantity 2 pieces
 (When 1 unit is needed)	Example of identification number indication LMG T 10 R300	Order quantity 1 unit
 (When 1 set is needed)	Example of identification number indication LMG T 10 C2 R300 /U	Order quantity 1 set

Moment of Inertia of Sectional Area and Section Coefficient of Shaft with Grooved Raceway

Table 5 Moment of inertia of sectional area and section coefficient of shaft with grooved raceway

Size	Moment of inertia of sectional area mm ⁴		Section coefficient mm ³	
	Solid shaft	Hollow shaft	Solid shaft	Hollow shaft
6	60	59	20	20
8	190	190	49	48
10	470	460	95	93
13	1 360	1 300	210	200
16	3 130	2 930	390	360
20	7 720	7 230	770	720

Lubrication

Grease is not pre-packed in the LMG series, so please perform adequate lubrication as needed. Both oil lubrication and grease lubrication are available in the LMG series. For grease lubrication, use of high-quality lithium-soap base grease is recommended.

Dust Protection

No dust protection seal is provided for LMG series. For applications in other than clean environment, cover the entire unit with a protective case, etc. to prevent harmful foreign substances such as dust and particles from outside from entering. The special specification with end seals (supplemental code / U) has a dust protection effect. However, if large amount of contaminant or dust are floating, or if large particles of foreign substances such as chips or sand may adhere to the shaft with grooved raceway, it is recommended to attach a protective cover to the linear motion mechanism.

Precaution for Use

1 Fitting of external cylinder

Generally, clearance fit (H7) is recommended for fitting between the external cylinder and the housing bore. The transition fit (J7) may be applied for special use.

2 Typical mounting structure

Mounting examples of the external cylinder are shown in Fig. 1. The fixing thread depth of mounting screws for the external cylinder must not exceed the maximum fixing thread depth indicated in the dimension table. Since the screw hole for the external cylinder is penetrated, the shaft with grooved raceway will be pushed by the screw if the fixing thread depth is too deep, and the running accuracy and life will be adversely affected.

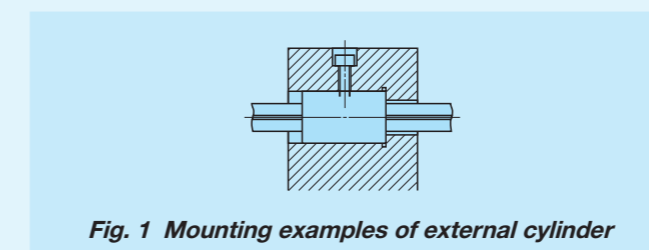

Fig. 1 Mounting examples of external cylinder

3 Multiple external cylinders used in close proximity

When using multiple external cylinders in close distance to the same housing, it is recommended to ensure that the distance between the external cylinders is three times as long as the length of the external cylinder. When using multiple external cylinders in closer distance, contact **IKO**.

4 Loaded condition with rotating torque

Use **IKO** Linear Ball Spline G under loaded conditions with a rotating torque bi-directionally or repeatedly.

5 Operating temperature

The maximum operating temperature is 120°C and temperature up to 100°C is allowed for continuous operation. When the temperature exceeds 100°C, contact **IKO**.

6 Mounting of external cylinder

When press-fitting the external cylinder to the housing, assemble them correctly by using a press and a suitable jig fixture. (See Fig. 2.)

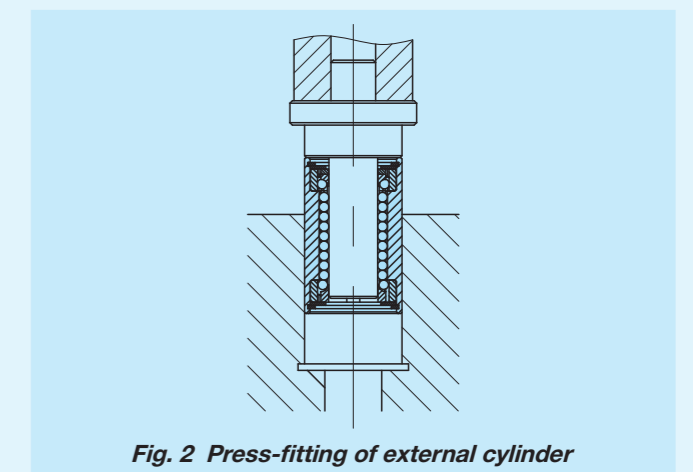
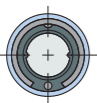
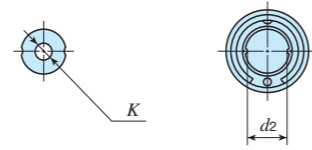
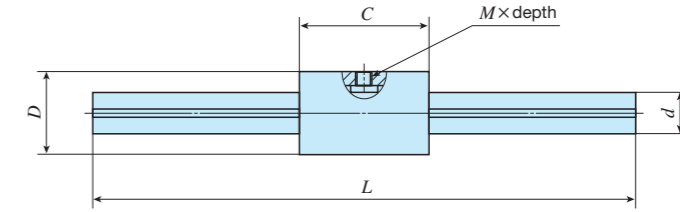

Fig. 2 Press-fitting of external cylinder

Shape	LMG					
						
Size	6	8	10	13	16	20



Hollow shaft dimension for LMGT



Identification number	Interchangeable	Mass (Ref.) g		Nominal dimensions and tolerances mm										Basic dynamic load rating C N	Basic static load rating C ₀ N	Dynamic torque rating T N·m	Static torque rating T ₀ N·m	
		External cylinder	Shaft with grooved raceway (1)	D	Dim. D tolerance	C	Dim. C tolerance	M×depth (2)	d	Dim. d tolerance	d ₂ (3)	K	L(4)					Maximum length
LMG 6	○	9.4	22.0	12	0 -0.011	19	0 -0.200	M2.5×1.9 (2.5)	6	0 -0.012	5.2	-	150 200	300	587	641	2.1	2.2
LMGT 6	○		19.5															
LMG 8	○	15.7	39.3	15	0 -0.011	24	0 -0.200	M3 ×2.4 (3)	8	0 -0.015	7	-	150 200 250	500	769	962	3.5	4.3
LMGT 8	○		33.7											400				
LMG 10	○	31.5	61.2	19	0 -0.013	29	0 -0.200	M3 ×3.1 (4)	10	0 -0.015	8.9	-	200 300	600	1 410	1 710	8.0	9.7
LMGT 10	○		51.4															
LMG 13	○	45.4	104	23	0 -0.013	32	0 -0.200	M3 ×3.4 (4.5)	13	0 -0.018	11.9	-	200 300 400	800	1 880	2 150	13.7	15.7
LMGT 13	○		81.4															
LMG 16	○	78.2	157	28	0 -0.013	37	0 -0.200	M4 ×4.1 (5.5)	16	0 -0.018	14	-	200 300 400	1 000	2 590	2 930	23.1	26.1
LMGT 16	○		118															
LMG 20	○	110	246	32	0 -0.016	42	0 -0.200	M4 ×4.1 (5.5)	20	0 -0.021	17.5	-	300 400 500 600	1 000	3 010	3 660	32.8	39.9
LMGT 20	○		185															

- Notes (1) The mass of the shaft with grooved raceway is the value per 100 mm of the track groove part.
 (2) The values in () are the maximum fixing thread depth.
 (3) d₂ represents the maximum diameter for end machining.
 (4) Represents standard length. We can produce other than the standard length, please specify the length of the shaft with grooved raceway by indicating the length in mm with the identification number.
 (5) Applicable under loaded conditions with an unidirectional torque at all times.
 Use IKO Linear Ball Spline G under loaded conditions with a rotating torque bi-directionally or repeatedly.

Remark: Linear Bushing G are all interchangeable specification.

LMG · LM · LMS

Linear Bushing

LM



Points

● Simple replacement for rolling guide

Since the structure adopts the raceway to be run along the shaft, the rolling guide of conventional bushing type can be easily modified to rolling guide without major design changes.

● Wide range of variations for your needs

For each dimensional series, standard, adjustable clearance, and open types are available with and without seals. You can select an optimal linear bushing for the specifications of your machine and device.

● Stainless steel superior in corrosion resistance are listed on lineup.

Products made of stainless steel are highly resistant to corrosion, so that they are suitable for applications where rust prevention oil is not preferred, such as in a cleanroom environment.

Identification Number and Specification

Example of an identification number

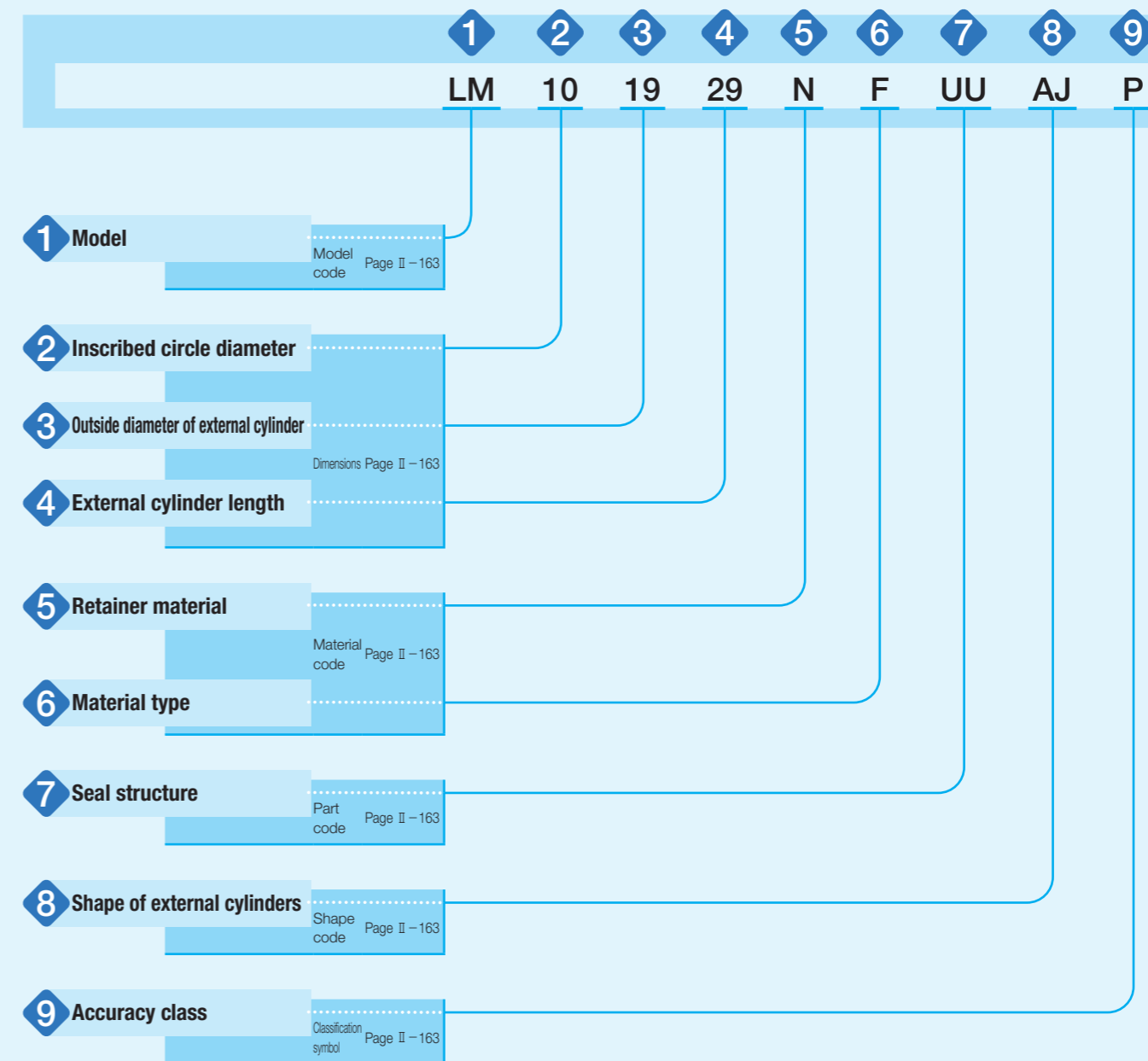

The specification of LM series is indicated by the identification number. Indicate the identification number, consisting of a model code, dimensions, a material code, a part code, a shape code, and a classification symbol for each specification to apply.



1 Model	Linear Bushing (LM Series)	Metric series : LM : LME (European specification (1)) Inch series : LMB	
	For applicable models and sizes, see Table 1.		
2 Inscribed circle diameter		For the metric series, indicate the inscribed circle diameter in mm. For the inch series, indicate the inscribed circle diameter in the unit of 1/16 inch.	
3 Outside diameter of external cylinder		For the metric series, indicate the outside diameter of external cylinder in mm. For the inch series, indicate the outside diameter of external cylinder in the unit of 1/16 inch.	
4 External cylinder length		For the metric series, indicate the length of the external cylinder in mm. For the inch series, indicate the length of external cylinder in the unit of 1/16 inch.	
5 Retainer material	High carbon steel made : No symbol Synthetic resin made : N	Specify the retainer material. For applicable models and sizes, see the "Identification number" column in the dimension table on pages II-167 to II-188.	
6 Material type	High carbon steel made : No symbol Stainless steel made : F	Specify the component part material. For applicable models and sizes, see the "Identification number" column in the dimension table on pages II-167 to II-188.	
7 Seal structure	Without seal : No symbol With one end seal : U With two end seals : UU	The models with one end seal and two end seals incorporate seals with superior dust protection performance for preventing intrusion of foreign substances. For the inch series, only the type without seal (no symbol) can be specified. The maximum allowable temperature for seals is 120°C.	
8 Shape of external cylinders	Standard type : No symbol Adjustable clearance type : AJ Open type : OP	For applicable models and sizes, see Table 1.	
9 Accuracy class	High : No symbol Precision : P	High class (no symbol) and precision class (P) are available for the accuracy class of LM and LMB standard type series. For the adjustable clearance type and the open type, only high class (no symbol) is available, and the accuracy values are applicable only before cutting the external cylinders. For details of accuracy, see the dimension table on pages II-167 to II-188.	

Note (1) It is specification with the dimensions and tolerances generally used in Europe.

Table 1 Models and sizes of LM series

External cylinder shape	Dimensional series	Material type	Seal structure	Model	Size (Shaft diameter)	
Standard type 	Metric series	High carbon steel made	Without seal	LM LME	6 ~150 mm 5 ~ 80 mm	
			With one end seal	LM ... U LME ... U	6 ~150 mm 5 ~ 80 mm	
			With two end seals	LM ... UU LME ... UU	6 ~150 mm 5 ~ 80 mm	
		Stainless steel made	Without seal	LM ... F LME ... F	6 ~ 60 mm 5 ~ 60 mm	
			With one end seal	LM ... F U LME ... F U	6 ~ 60 mm 5 ~ 60 mm	
			With two end seals	LM ... F UU LME ... F UU	6 ~ 60 mm 5 ~ 60 mm	
	Inch series	High carbon steel made	Without seal	LMB	6.350~101.6 mm (1/4~4in)	
	Adjustable clearance type 	Metric series	High carbon steel made	Without seal	LM ... AJ LME ... AJ	6 ~150 mm 5 ~ 80 mm
				With one end seal	LM ... U AJ LME ... U AJ	6 ~150 mm 5 ~ 80 mm
				With two end seals	LM ... UU AJ LME ... UU AJ	6 ~150 mm 5 ~ 80 mm
			Stainless steel made	Without seal	LM ... F AJ LME ... F AJ	6 ~ 60 mm 5 ~ 60 mm
				With one end seal	LM ... F U AJ LME ... F U AJ	6 ~ 60 mm 5 ~ 60 mm
With two end seals				LM ... F UU AJ LME ... F UU AJ	6 ~ 60 mm 5 ~ 60 mm	
Inch series		High carbon steel made	Without seal	LMB ... AJ	6.350~101.6 mm (1/4~4in)	
Open type 		Metric series	High carbon steel made	Without seal	LM ... OP LME ... OP	10 ~150 mm 12 ~ 80 mm
				With one end seal	LM ... U OP LME ... U OP	10 ~150 mm 12 ~ 80 mm
				With two end seals	LM ... UU OP LME ... UU OP	10 ~150 mm 12 ~ 80 mm
			Stainless steel made	Without seal	LM ... F OP LME ... F OP	10 ~ 60 mm 12 ~ 60 mm
				With one end seal	LM ... F U OP LME ... F U OP	10 ~ 60 mm 12 ~ 60 mm
	With two end seals			LM ... F UU OP LME ... F UU OP	10 ~ 60 mm 12 ~ 60 mm	
	Inch series	High carbon steel made	Without seal	LMB ... OP	12.700~101.6 mm (1/2~4in)	

Standard type : Product with high accuracy used generally over a wide range

Adjustable clearance type : This type has a cut-away slit in an axial direction of external cylinder, which is capable of clearance adjustment. If installed in a housing whose inscribed circle diameter is adjustable, it enables radial clearance to be freely adjusted without optional fitting and also enables preloading to operate.

Open type : This type is in sectoral form with the external cylinder cut away in slit by one-row raceway or two-row raceways of ball in an axial direction. In order to avoid the occurrence of long shaft deflection, it is possible to accordingly add the shaft support block tailored to (E) dimension of the sectoral form shown in the dimension table, in a midway point. And, it is also capable of clearance adjustment.

Relationship between Load Rating and Ball Raceway

The load rating of LM series varies according to the loading direction and position of ball raceway. The dimension table describes two types of values shown in Fig. 1.1 and Fig. 1.2 according to the loading direction and position of ball raceway.

Fig. 1.1 shows the case where the loading direction and ball raceway position coincides with each other, representing the loading direction A in the dimension table. Generally, this is applied when the ball raceway position cannot be specified to indeterminate direction load or loading direction.

Fig. 1.2 shows the case where the loading direction is positioned between ball raceways, representing the loading direction B in the dimension table. Generally, this can be subjected to load bigger than loading direction A.

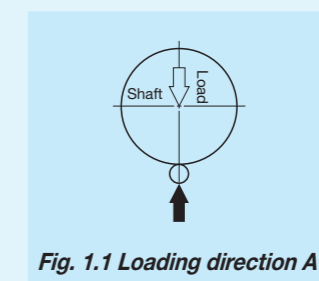

Fig. 1.1 Loading direction A

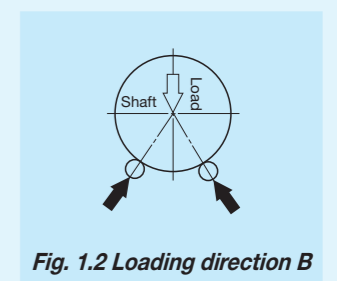

Fig. 1.2 Loading direction B

1N=0.102kgf=0.2248lbs.
1mm=0.03937inch

Lubrication

Grease is not pre-packed in the LM series, so please perform adequate lubrication as needed. Both of oil lubrication and grease lubrication are available in the LM series. For grease lubrication, use of high-quality lithium-soap base grease is recommended.

Precaution for Use

①Fitting

For fitting with a housing hole, clearance fit is usually used but transition fit can also be used for special usage. For adjustable clearance type and open type, the shaft diameter shall be set as much as possible to less than the lower limit of the allowance of the inscribed circle diameter, and while the dimension of a housing hole shall be set to more than the upper limit of the allowance of the outside diameter of the external cylinder.

Table 2 Recommended fit

Models and accuracy class	Tolerance class				
	Shaft		Housing hole		
	Ordinary clearance	Interference fit	Clearance fit	Transition fit	
LM, LMB	High	f6, g6	h6	H7	J7
	Precision	f5, g5	h5	H6	J6
LME	—	h6	j6	H7	J7

②Clearance

For adjustable clearance type and open type, clearance adjustment can be easily performed if the unit is mounted into a housing with the bore diameter dimension adjustable. However, if a large preload is produced due to the clearance adjustment, the deformation at the contact portion of the external cylinder and ball may become large, thereby deteriorating the life. Therefore, it is recommended to finish the shaft dimension within the allowance of the recommended fitting and set the clearance at zero or under a slightly-preloaded condition. Although the clearance adjustment is performed while measuring the clearance with a dial gauge after fitting in a shaft, a method is generally taken to rotate the shaft under unloaded condition during clearance adjustment and stop the adjustment at the timing when detecting a slight resistance. At this time, the linear bushing clearance is at zero or under a slight preload condition. Meanwhile, the clearance adjustment for open type with three-row ball raceways cannot be performed.

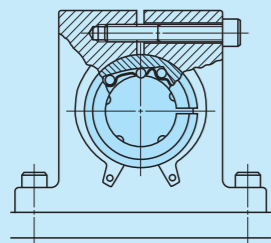

Fig. 2 Example of clearance adjustment

③Raceway

Since LM series operates with a shaft as a raceway surface, the shaft should be heat-treated and ground. Recommended values for surface hardness and roughness of the shaft are shown in Table 3 and the recommended value for the minimum effective hardening depth is shown in Table 4.

Table 3 Surface hardness and roughness of shaft

Item	Recommended value	Remark
Surface hardness	58~64HRC	When the surface hardness is low, multiply the load rating by hardness factor (1).
Surface roughness	0.2 μmRa or lower (0.8 μmRy or lower)	Where accuracy standard is low, around 0.8 μmRa (3.2 μmRy) is also allowed.

Note (1) For hardness factor, refer to Fig. 3 in page III-5.

Table 4 Minimum effective hardening depth of shaft unit: mm

Shaft diameter		Recommended value for minimum effective hardening depth
Over	Incl.	
—	28	0.8
28	50	1.0
50	100	1.5
100	150	2.0

④When accompanied by rotational motion

LM series units support only linear motion but do not support rotational motion. When performing rotational motion and linear motion of short stroke length, IKO stroke rotary bushing is recommended to be used. And, for the usage requiring rotational motion and linear motion of long stroke length, it is recommended to use in combination with IKO needle bearing as shown in Fig. 3.

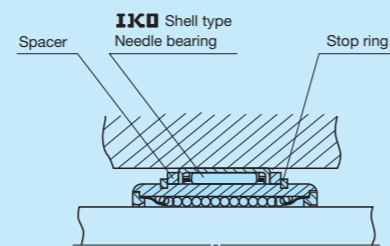

Fig. 3 Example of linear motion and rotational motion

⑤Precaution for use of open type with three-row linear bushing

The open type with three-row linear bushing of balls may only be used with load direction indicated in Fig. 4.1. In addition, if two of them are used in parallel, mount them as indicated in 4.2, taking into account the load distribution to rolling elements. And, note that the clearance adjustment cannot be performed.

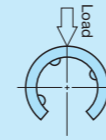

Fig. 4.1

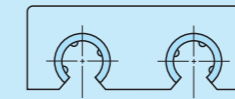

Fig. 4.2

⑥Operating temperature

If the retainer is made of carbon steel, it can withstand higher temperature. However, if you use it in an environment exceeding 100°C, please contact IKO. The maximum operating temperature of synthetic resin made products is 100°C and temperature up to 80°C is allowed for continuous operation.

⑦Mounting

When pressing an external cylinder into the housing hole, do it softly while applying a jig to the sides of the external cylinder not to hit the end plate (see Fig. 5). After pressing-in, use a stop ring or stopper plate to fix it in an axial direction. When inserting shaft after mounting the external cylinder, be careful not to shock the ball or retainer. In addition, when two shafts are used, mount one accurately and then the other by referring to the first one so as to ensure parallelism with it. Typical mounting example is shown in Fig. 6.

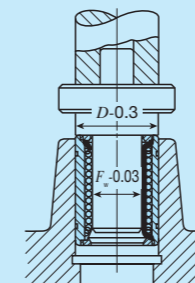

Fig. 5 Press-fitting of external cylinder

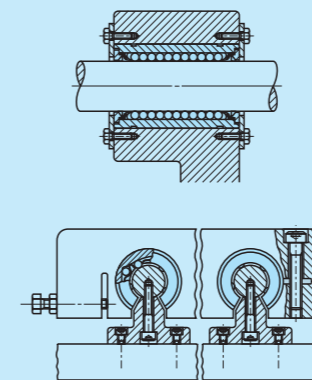

Fig. 6 Mounting example

Related Products

Slide shaft

To make full use of performance of the LM series, we also offer shaft with high accuracy for linear bushing grounded after heat treatment. If you are interested, contact IKO. Conventional ordinary type shafts are also available.

Felt seals for Linear Bushing

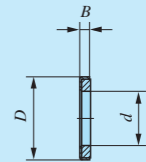

Though the type with seal is standardized for the LM series, the type without seal and felt seals may be used together when emphasis is put on rolling friction resistance. Dimensions for felt seals are shown in Table 5.

Table 5 Dimensions of felt seals for Linear Bushing



Identification number	unit: mm		
	d	D	B
FLM 6	6	12	2
FLM 8	8	15	2
FLM 10	10	19	3
FLM 13	13	23	3
FLM 16	16	28	4
FLM 20	20	32	4
FLM 25	25	40	5
FLM 30	30	45	5
FLM 35	35	52	5
FLM 40	40	60	5
FLM 50	50	80	10
FLM 60	60	90	10
FLM 80	80	120	10
FLM 100	100	150	10

Remark: For adjustable clearance type, open type and inch series felt seals, contact IKO.

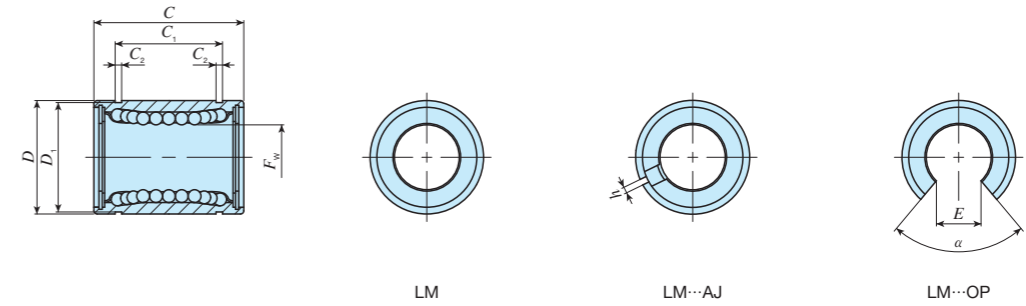

	Standard type					Adjustable clearance type					Open type							
Shape	LM LM...N					LM...AJ LM...N AJ					LM...OP LM...N OP							
																		
Shaft diameter	6	8	10	12	13	16	6	8	10	12	13	16	—	—	10	12	13	16
	20	25	30	35	40	50	20	25	30	35	40	50	20	25	30	35	40	50
	60	80	100	120	150	60	80	100	120	150	60	80	100	120	150			



Shaft diameter mm	Identification number										Nominal dimensions and tolerances mm										Eccentricity		Basic dynamic load rating		Basic static load rating								
	Standard type		Ball raceway	Mass (Ref.) g	Adjustable clearance type		Ball raceway	Mass (Ref.) g	Open type		Ball raceway	Mass (Ref.) g	F _w	Dim. F _w tolerance μm		D	Dim. D tolerance μm	C	Dim. C tolerance μm	C ₁ (¹)	Dim. C ₁ tolerance μm	C ₂	D ₁	h	E	α	Maximum μm	P	H	Load direction A N	Load direction B N	Load direction A N	Load direction B N
6	LM	61219	4	8	—	—	—	—	—	—	—	—	6			12		19		13.5		1.1	11.5	—	—	—	—	—	—	80.7	92.7	167	237
	LM	61219 N	4	7.6	LM	61219 N AJ*	4	7.5	—	—	—	—											1	—	—	—	—	—	—	—	—		
8	LM	81517	4	13	—	—	—	—	—	—	—	—	8			15	0	17		11.5		1.1	14.3	—	—	—	—	—	—	87.4	100	160	226
	LM	81517 N	4	10.4	LM	81517 N AJ*	4	10	—	—	—	—											1	—	—	—	—	—	—	—	—		
	LM	81524	4	18	—	—	—	—	—	—	—	—	8			15		24		17.5		1.1	14.3	—	—	—	—	—	—	121	139	255	361
	LM	81524 N	4	15	LM	81524 N AJ*	4	14.7	—	—	—	—											1	—	—	—	—	—	—	—	—		
10	LM	101929	4	30	—	—	—	—	—	—	—	—	10	0	0	19		29		22		1.3	18	—	—	—	—	—	—	179	206	354	501
	LM	101929 N	4	27.5	LM	101929 N AJ*	4	26.5	LM	101929 N OP*	3	18		-6	-9				0	0			1	6.8	80	8	12						
12	LM	122130	4	29	LM	122130 AJ*	4	28	LM	122130 OP*	3	19	12			21	0	30	-200	23	-200	1.3	20	1.5	8	80			259	298	503	711	
	LM	122130 N	4	31.5	LM	122130 N AJ*	4	30.5	LM	122130 N OP*	3	22																					
13	LM	132332	4	43	LM	132332 AJ*	4	42	LM	132332 OP*	3	31	13			23	-13	32		23		1.3	22	1.5	9	80			266	306	506	716	
	LM	132332 N	4	42.5	LM	132332 N AJ*	4	41.5	LM	132332 N OP*	3	31																					
16	LM	162837	4	70	LM	162837 AJ*	4	69.5	LM	162837 OP*	3	58	16			28		37		26.5		1.6	27	1.5	11	80			426	489	766	1 080	
	LM	162837 N	4	69	LM	162837 N AJ*	4	68	LM	162837 N OP*	3	52																					
20	LM	203242	5	92	LM	203242 AJ*	5	91	LM	203242 OP*	4	79	20			32		42		30.5		1.6	30.5	1.5	11	60			562	668	1 010	1 470	
	LM	203242 N	5	87	LM	203242 N AJ*	5	85	LM	203242 N OP*	4	69																					
25	LM	254059	6	226	LM	254059 AJ*	6	222	LM	254059 OP*	5	203	25	0	0	40	0	59		41		1.85	38	2	12	50	10	15	920	974	1 780	2 280	
	LM	254059 N	6	220	LM	254059 N AJ*	6	216	LM	254059 N OP*	5	188		-7	-10		-16																
30	LM	304564	6	253	LM	304564 AJ*	6	250	LM	304564 OP*	5	228	30			45		64		44.5		1.85	43	2.5	15	50			1 350	1 430	2 500	3 200	
	LM	304564 N	6	250	LM	304564 N AJ*	6	245	LM	304564 N OP*	5	210																					
35	LM	355270	6	388	LM	355270 AJ*	6	380	LM	355270 OP*	5	355	35			52		70	0	49.5	0	2.1	49	2.5	17	50			1 610	1 710	3 080	3 940	
	LM	355270 N	6	380	LM	355270 N AJ*	6	375	LM	355270 N OP*	5	335																					
40	LM	406080	6	596	LM	406080 AJ*	6	585	LM	406080 OP*	5	546	40	0	0	60	0	80		60.5		2.1	57	3	20	50	12	20	2 030	2 150	3 620	4 640	
	LM	406080 N	6	585	LM	406080 N AJ*	6	579	LM	406080 N OP*	5	500		-8	-12		-19																
50	LM	5080100	6	1 615	LM	5080100 AJ*	6	1 595	LM	5080100 OP*	5	1 420	50			80		100		74		2.6	76.5	3	25	50			3 940	4 180	7 130	9 120	
	LM	5080100 N	6	1 580	LM	5080100 N AJ*	6	1 560	LM	5080100 N OP*	5	1 340																					

Note (1) The width of hub for fixing with circlip should be the value obtained by subtracting a circlip width value times two from the C₁ dimension.

- Remarks 1. "P" and "H" in Dim. F_w tolerance and Eccentricity represent precision and high, respectively.
 2. Standard type and adjustable clearance type end plates are fixed with stop ring for holes.
 3. The identification numbers with * are our semi-standard items.

	Standard type						Adjustable clearance type						Open type											
Shape	LM LM...N						LM... AJ LM...N AJ						LM... OP LM...N OP											
																								
Shaft diameter	6	8	10	12	13	16	6	8	10	12	13	16	—	—	10	12	13	16	6	8	10	12	13	16
	20	25	30	35	40	50	20	25	30	35	40	50	20	25	30	35	40	50	20	25	30	35	40	50
	60	80	100	120	150	60	80	100	120	150	60	80	100	120	150	60	80	100	120	150				

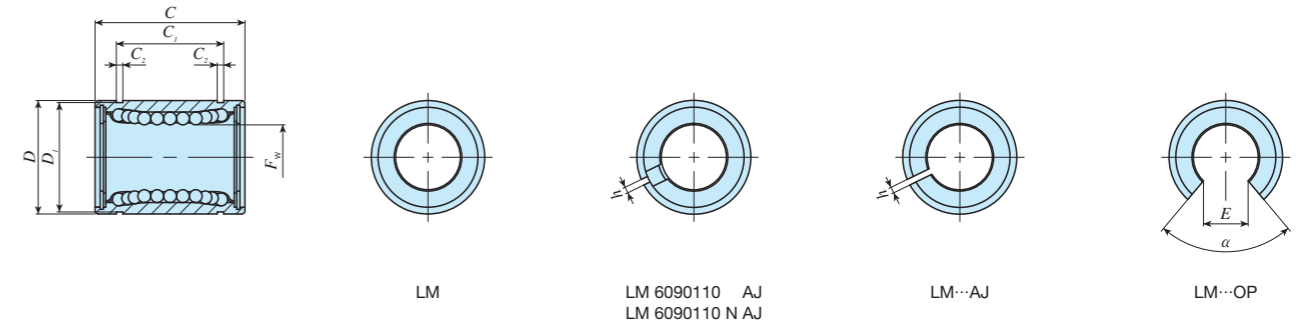



Shaft diameter mm	Identification number										Nominal dimensions and tolerances mm												Eccentricity		Basic dynamic load rating		Basic static load rating						
	Standard type		Ball raceway	Mass (Ref.) g	Adjustable clearance type		Ball raceway	Mass (Ref.) g	Open type		Ball raceway	Mass (Ref.) g	F_w	Dim. F_w tolerance μm		D	Dim. D tolerance μm	C	Dim. C tolerance μm	$C_1^{(1)}$	Dim. C_1 tolerance μm	C_2	D_1	h	E	α Degree	Maximum μm	P	H	C		C_0	
	P	H			P	H			P	H				Load direction A N	Load direction B N															Load direction A N	Load direction B N		
60	LM 6090110	6	1 817	LM 6090110 AJ*	6	1 788	LM 6090110 OP*	5	1 650			60	0	0	90	0	110	0	85	0	3.15	86.5	3	30	50	17	25	4 760	5 040	8 150	10 400		
	LM 6090110 N	6	1 787	LM 6090110 N AJ*	6	1 757	LM 6090110 N OP*	5	1 610			60	-9	-15	120	-22	140	-300	105.5	-300	4.15	116	3	40	50	17	25	8 710	9 220	14 500	18 500		
80	LM 80120140*	6	4 520	LM 80120140 AJ*	6	4 400	LM 80120140 OP*	5	3 750			80	0	0	150	0	175	0	125.5	0	4.15	145	3	50	50	20	30	14 500	15 300	22 800	29 200		
100	LM 100150175*	6	8 600	LM 100150175 AJ*	6	8 540	LM 100150175 OP*	5	7 200			100	0	0	150	0	175	0	125.5	0	4.15	145	3	50	50	20	30	14 500	15 300	22 800	29 200		
120	LM 120180200*	8	15 000	LM 120180200 AJ*	8	14 900	LM 120180200 OP*	6	11 600			120	-10	-20	180	-25	200	-400	158.6	-400	4.15	175	3	85	80	20	30	25 800	25 500	44 300	49 400		
150	LM 150210240*	8	20 250	LM 150210240 AJ*	8	20 150	LM 150210240 OP*	6	15 700			150	0	0	210	0	240	0	170.6	0	5.15	204	3	105	80	25	40	35 600	35 100	61 200	68 200		

Note (1) The width of hub for fixing with circlip should be the value obtained by subtracting a circlip width value times two from the C_1 dimension.

- Remarks
- "P" and "H" in Dim. F_w tolerance and Eccentricity represent precision and high, respectively.
 - Standard type and adjustable clearance type (shaft diameter 60 mm) end plates are fixed with stop ring for holes.
 - The identification numbers with * are our semi-standard items.

LMG • LM • LMS

IKO Linear Bushing With Seal

	Standard type					Adjustable clearance type					Open type							
Shape	LM... UU LM...N UU					LM... UU AJ LM...N UU AJ					LM... UU OP LM...N UU OP							
																		
Shaft diameter	6	8	10	12	13	16	6	8	10	12	13	16	—	—	10	12	13	16
	20	25	30	35	40	50	20	25	30	35	40	50	20	25	30	35	40	50
	60	80	100	120	150	60	80	100	120	150	60	80	100	120	150			

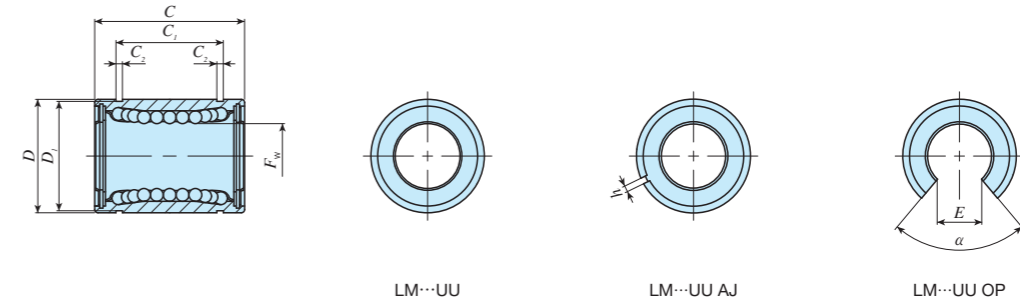



Shaft diameter mm	Identification number										Nominal dimensions and tolerances mm													Eccentricity		Basic dynamic load rating		Basic static load rating					
	Standard type		Ball raceway	Mass (Ref.) g	Adjustable clearance type		Ball raceway	Mass (Ref.) g	Open type		Ball raceway	Mass (Ref.) g	F _w	Dim. F _w tolerance μm		D	Dim. D tolerance μm	C	Dim. C tolerance μm	C ₁ (¹)	Dim. C ₁ tolerance μm	C ₂	D ₁	h	E	α	Maximum μm	P	H	Load direction A N	Load direction B N	Load direction A N	Load direction B N
6	LM 61219 UU	4	8	—	—	—	—	—	—	—	—	6			12		19		13.5		1.1	11.5	—	—	—				80.7	92.7	167	237	
	LM 61219 N UU	4	7.6	LM 61219 N UU AJ*	4	7.5	—	—	—	—	—	8			15	0 -11	17		11.5		1.1	14.3	—	—	—				87.4	100	160	226	
8	LM 81517 UU	4	13	—	—	—	—	—	—	—	—	8			15		24		17.5		1.1	14.3	—	—	—				121	139	255	361	
	LM 81524 N UU	4	15	LM 81524 N UU AJ*	4	14.7	—	—	—	—	—	8			15		24		17.5		1.1	14.3	—	—	—				121	139	255	361	
10	LM 101929 UU	4	30	—	—	—	—	—	—	—	—	10	0 -6	0 -9	19		29		22		1.3	18	—	—	—	8	12	179	206	354	501		
	LM 101929 N UU	4	27.5	LM 101929 N UU AJ*	4	26.5	LM 101929 N UU OP*	3	18	—	—	10			19		29	0 -200	22	0 -200	1.3	18	—	—	—				179	206	354	501	
12	LM 122130 UU	4	29	LM 122130 UU AJ*	4	28	LM 122130 UU OP*	3	19	—	—	12			21	0	30		23		1.3	20	1.5	8	80			259	298	503	711		
	LM 122130 N UU	4	31.5	LM 122130 N UU AJ*	4	30.5	LM 122130 N UU OP*	3	22	—	—	12			21	0 -13	30		23		1.3	20	1.5	8	80			259	298	503	711		
13	LM 132332 UU	4	43	LM 132332 UU AJ*	4	42	LM 132332 UU OP*	3	31	—	—	13			23		32		23		1.3	22	1.5	9	80			266	306	506	716		
	LM 132332 N UU	4	42.5	LM 132332 N UU AJ*	4	41.5	LM 132332 N UU OP*	3	31	—	—	13			23		32		23		1.3	22	1.5	9	80			266	306	506	716		
16	LM 162837 UU	4	70	LM 162837 UU AJ*	4	69.5	LM 162837 UU OP*	3	58	—	—	16			28		37		26.5		1.6	27	1.5	11	80			426	489	766	1 080		
	LM 162837 N UU	4	69	LM 162837 N UU AJ*	4	68	LM 162837 N UU OP*	3	52	—	—	16			28		37		26.5		1.6	27	1.5	11	80			426	489	766	1 080		
20	LM 203242 UU	5	92	LM 203242 UU AJ*	5	91	LM 203242 UU OP*	4	79	—	—	20			32		42		30.5		1.6	30.5	1.5	11	60			562	668	1 010	1 470		
	LM 203242 N UU	5	87	LM 203242 N UU AJ*	5	85	LM 203242 N UU OP*	4	69	—	—	20			32		42		30.5		1.6	30.5	1.5	11	60			562	668	1 010	1 470		
25	LM 254059 UU	6	226	LM 254059 UU AJ*	6	222	LM 254059 UU OP*	5	203	—	—	25	0 -7	0 -10	40	0 -16	59		41		1.85	38	2	12	50	10	15	920	974	1 780	2 280		
	LM 254059 N UU	6	220	LM 254059 N UU AJ*	6	216	LM 254059 N UU OP*	5	188	—	—	25			40		59		41		1.85	38	2	12	50			920	974	1 780	2 280		
30	LM 304564 UU	6	253	LM 304564 UU AJ*	6	250	LM 304564 UU OP*	5	228	—	—	30			45		64		44.5		1.85	43	2.5	15	50			1 350	1 430	2 500	3 200		
	LM 304564 N UU	6	250	LM 304564 N UU AJ*	6	245	LM 304564 N UU OP*	5	210	—	—	30			45		64		44.5		1.85	43	2.5	15	50			1 350	1 430	2 500	3 200		
35	LM 355270 UU	6	387	LM 355270 UU AJ*	6	380	LM 355270 UU OP*	5	355	—	—	35			52		70	0 -300	49.5	0 -300	2.1	49	2.5	17	50			1 610	1 710	3 080	3 940		
	LM 355270 N UU	6	380	LM 355270 N UU AJ*	6	375	LM 355270 N UU OP*	5	335	—	—	35			52		70		49.5		2.1	49	2.5	17	50			1 610	1 710	3 080	3 940		
40	LM 406080 UU	6	596	LM 406080 UU AJ*	6	585	LM 406080 UU OP*	5	546	—	—	40	0 -8	0 -12	60	0 -19	80		60.5		2.1	57	3	20	50	12	20	2 030	2 150	3 620	4 640		
	LM 406080 N UU	6	585	LM 406080 N UU AJ*	6	579	LM 406080 N UU OP*	5	500	—	—	40			60		80		60.5		2.1	57	3	20	50			2 030	2 150	3 620	4 640		
50	LM 5080100 UU	6	1 615	LM 5080100 UU AJ*	6	1 595	LM 5080100 UU OP*	5	1 420	—	—	50			80		100		74		2.6	76.5	3	25	50			3 940	4 180	7 130	9 120		
	LM 5080100 N UU	6	1 580	LM 5080100 N UU AJ*	6	1 560	LM 5080100 N UU OP*	5	1 340	—	—	50			80		100		74		2.6	76.5	3	25	50			3 940	4 180	7 130	9 120		

Note (1) The width of hub for fixing with circlip should be the value obtained by subtracting a circlip width value times two from the C₁ dimension.

- Remarks 1. "P" and "H" in Dim. F_w tolerance and Eccentricity represent precision and high, respectively.
 2. Standard type and adjustable clearance type end plates are fixed with stop ring for holes.
 3. The identification numbers with * are our semi-standard items.

IKO Linear Bushing With Seal

	Standard type						Adjustable clearance type						Open type					
Shape	LM... UU LM...N UU						LM... UU AJ LM...N UU AJ						LM... UU OP LM...N UU OP					
																		
Shaft diameter	6	8	10	12	13	16	6	8	10	12	13	16	—	—	10	12	13	16
	20	25	30	35	40	50	20	25	30	35	40	50	20	25	30	35	40	50
	60	80	100	120	150		60	80	100	120	150		60	80	100	120	150	

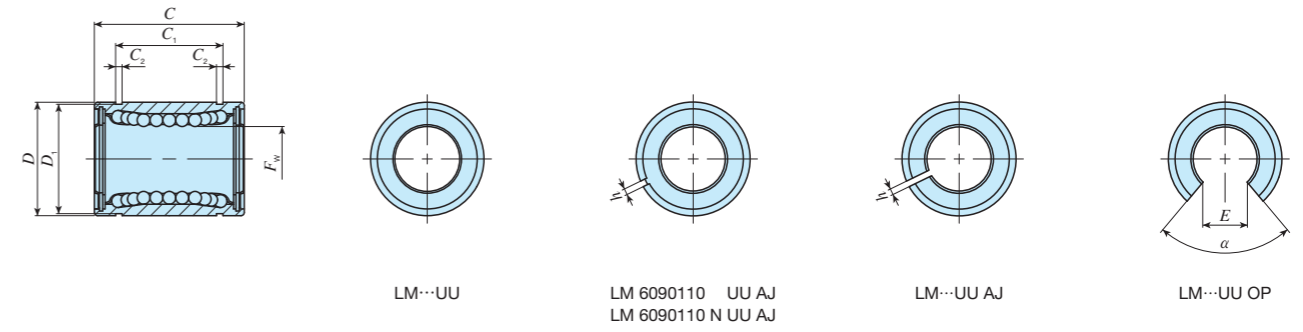

Shaft diameter mm	Identification number										Nominal dimensions and tolerances mm														Eccentricity		Basic dynamic load rating		Basic static load rating			
	Standard type		Ball raceway	Mass (Ref.)	Adjustable clearance type		Ball raceway	Mass (Ref.)	Open type		Ball raceway	Mass (Ref.)	F _w	Dim. F _w tolerance μm		D	Dim. D tolerance μm	C	Dim. C tolerance μm	C ₁ (¹)	Dim. C ₁ tolerance μm	C ₂	D ₁	h	E	α	Maximum μm		Load direction A	Load direction B	Load direction A	Load direction B
	P	H	P	H	P	H	P	H	P	H	P	H		P	H												P	H				
60	LM 6090110 UU	6	1 817	LM 6090110 UU AJ*	6	1 788	LM 6090110 UU OP*	5	1 650			60	0	0	90	0	110	0	85	0	3.15	86.5	3	30	50	17	25	4 760	5 040	8 150	10 400	
	LM 6090110 N UU	6	1 787	LM 6090110 N UU AJ*	6	1 757	LM 6090110 N UU OP*	5	1 610			80	-9	-15	120	-22	140															
80	LM 80120140 UU*	6	4 400	LM 80120140 UU AJ*	6	4 360	LM 80120140 UU OP*	5	3 640			100	0	0	150	0	175	0	125.5	0	4.15	145	3	50	50	20	30	14 500	15 300	22 800	29 200	
120	LM 120180200 UU*	8	14 700	LM 120180200 UU AJ*	8	14 600	LM 120180200 UU OP*	6	11 400			120	-10	-20	180	-25	200	-400	158.6	-400	4.15	175	3	85	80			25 800	25 500	44 300	49 400	
150	LM 150210240 UU*	8	19 900	LM 150210240 UU AJ*	8	19 800	LM 150210240 UU OP*	6	15 400			150	0	0	210	0	240		170.6		5.15	204	3	105	80	25	40	35 600	35 100	61 200	68 200	

Note (1) The width of hub for fixing with circlip should be the value obtained by subtracting a circlip width value times two from the C₁ dimension.

- Remarks 1. "P" and "H" in Dim. F_w tolerance and Eccentricity represent precision and high, respectively.
 2. Standard type and adjustable clearance type (shaft diameter 60 mm) end plates are fixed with stop ring for holes.
 3. The identification numbers with * are our semi-standard items.

LMG • LM • LMS

	Standard type					Adjustable clearance type					Open type								
Shape	LME LME...N					LME... AJ LME...N AJ					LME... OP LME...N OP								
Shaft diameter	5	8	12	16	20	25	5	8	12	16	20	25	—	—	12	16	20	25	
	30	40	50	60	80	30	40	50	60	80	30	40	50	60	80				

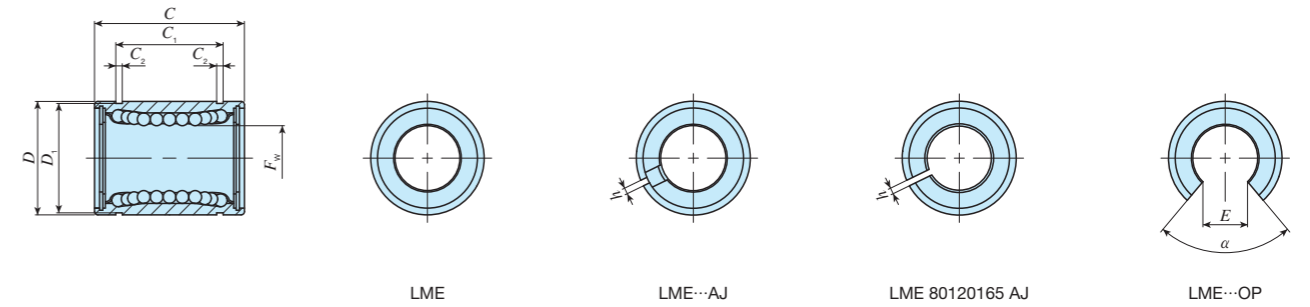



Shaft diameter mm	Identification number										Nominal dimensions and tolerances mm											Eccentricity Maximum μm	Basic dynamic load rating C		Basic static load rating C ₀					
	Standard type		Ball raceway	Mass (Ref.) g	Adjustable clearance type		Ball raceway	Mass (Ref.) g	Open type		Ball raceway	Mass (Ref.) g	F _w	Dim. F _w tolerance μm	D	Dim. D tolerance μm	C	Dim. C tolerance μm	C ₁ (¹)	Dim. C ₁ tolerance μm	C ₂		D ₁	h	E	α Degree	Load direction A N	Load direction B N	Load direction A N	Load direction B N
5	LME	51222 N*	4	11	LME	51222 N AJ*	4	9.5	—	—	—	5		12		22		14.5		1.1	11.5	1	—	—	12	90.8	104	219	310	
8	LME	81625 *	4	20	—	—	—	—	—	—	—	8	+ 8 0	16	- 8	25		16.5		1.1	15.2	1	—	—		121	139	255	361	
	LME	81625 N*	4	20	LME	81625 N AJ*	4	19.5	—	—	—																			
12	LME	122232 *	4	41.5	LME	122232 AJ*	4	40.5	LME	122232 OP*	3	32	12		22	0	32	-200	22.9	-200	1.3	21	1.5	7.5	78	12	259	298	503	711
	LME	122232 N*	4	40	LME	122232 N AJ*	4	39	LME	122232 N OP*	3	30																		
16	LME	162636 *	4	56.5	LME	162636 AJ*	4	55.5	LME	162636 OP*	3	48	16	+ 9 - 1	26	- 9	36		24.9		1.3	24.9	1.5	10	78		283	325	514	726
	LME	162636 N*	4	55	LME	162636 N AJ*	4	54	LME	162636 N OP*	3	46																		
20	LME	203245 *	5	97	LME	203245 AJ*	5	96	LME	203245 OP*	4	84	20		32		45		31.5		1.6	30.3	2	10	60		562	668	1 010	1 470
	LME	203245 N*	5	91	LME	203245 N AJ*	5	90	LME	203245 N OP*	4	75																		
25	LME	254058 *	6	222	LME	254058 AJ*	6	219	LME	254058 OP*	5	195	25	+11 - 1	40	0	58		44.1		1.85	37.5	2	12.5	60	15	920	974	1 780	2 280
	LME	254058 N*	6	215	LME	254058 N AJ*	6	212	LME	254058 N OP*	5	181																		
30	LME	304768 *	6	338	LME	304768 AJ*	6	333	LME	304768 OP*	5	309	30		47	0	68	-300	52.1	-300	1.85	44.5	2	12.5	50		1 350	1 430	2 500	3 200
	LME	304768 N*	6	325	LME	304768 N AJ*	6	320	LME	304768 N OP*	5	272																		
40	LME	406280 *	6	712	LME	406280 AJ*	6	701	LME	406280 OP*	5	665	40		62	0	80		60.6		2.15	59	3	16.8	50	17	2 030	2 150	3 620	4 640
	LME	406280 N*	6	705	LME	406280 N AJ*	6	694	LME	406280 N OP*	5	600																		
50	LME	5075100 *	6	1 147	LME	5075100 AJ*	6	1 127	LME	5075100 OP*	5	1 080	50	+13 - 2	75	-13	100		77.6		2.65	72	3	21	50		3 940	4 180	7 130	9 120
	LME	5075100 N*	6	1 130	LME	5075100 N AJ*	6	1 110	LME	5075100 N OP*	5	970																		
60	LME	6090125 *	6	2 051	LME	6090125 AJ*	6	2 001	LME	6090125 OP*	5	1 900	60		90	0	125	-400	101.7	-400	3.15	86.5	3	27.2	54	20	4 760	5 040	8 150	10 400
	LME	6090125 N*	6	2 050	LME	6090125 N AJ*	6	2 000	LME	6090125 N OP*	5	1 580																		
80	LME	80120165 *	6	5 140	LME	80120165 AJ*	6	5 000	LME	80120165 OP*	5	4 380	80	+16 - 4	120	-15	165		133.7		4.15	116	3	36.3	54		8 710	9 220	14 500	18 500

Note (1) The width of hub for fixing with circlip should be the value obtained by subtracting a circlip width value times two from the C₁ dimension.

- Remarks 1. High carbon steel-made retainer (shaft diameter 8 mm), and standard type and adjustable clearance type (shaft diameter 12 mm to 60 mm) end plates are fixed with stop ring for holes.
2. The identification numbers with * are our semi-standard items.

LMG • LM • LMS

IKO Linear Bushing With Seal

	Standard type					Adjustable clearance type					Open type								
Shape	LME... UU LME...N UU					LME... UU AJ LME...N UU AJ					LME... UU OP LME...N UU OP								
																			
Shaft diameter	5	8	12	16	20	25	5	8	12	16	20	25	—	—	12	16	20	25	
	30	40	50	60	80	30	40	50	60	80	30	40	50	60	80				

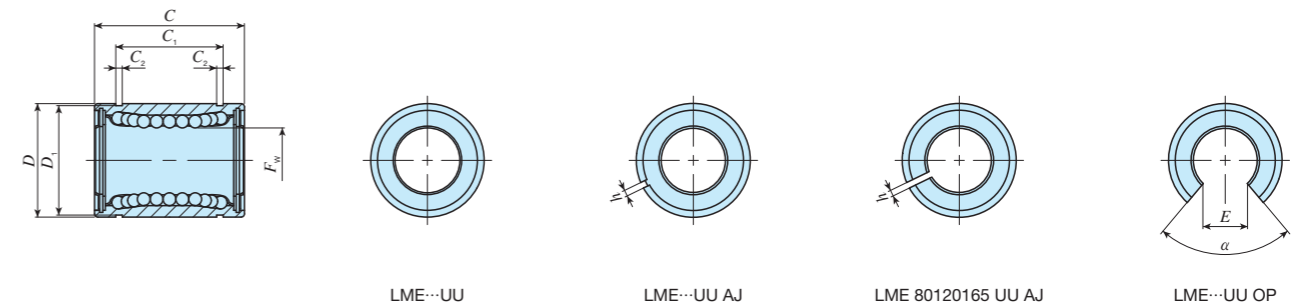

Shaft diameter mm	Identification number										Nominal dimensions and tolerances mm											Eccentricity Maximum μm	Basic dynamic load rating C		Basic static load rating C ₀					
	Standard type		Ball raceway	Mass (Ref.) g	Adjustable clearance type		Ball raceway	Mass (Ref.) g	Open type		Ball raceway	Mass (Ref.) g	F _w	Dim. Fw tolerance μm	D	Dim. D tolerance μm	C	Dim. C tolerance μm	C ₁ (¹)	Dim. C ₁ tolerance μm	C ₂		D ₁	h	E	α Degree	Load direction A N	Load direction B N	Load direction A N	Load direction B N
5	LME	51222 N UU*	4	11	LME	51222 N UU AJ*	4	9.5	—		—	—	5		12		22		14.5		1.1	11.5	1	—	—	12	90.8	104	219	310
8	LME	81625 UU*	4	20	—		—	—	—		—	—	8	+ 8 0	16	- 8	25		16.5		1.1	15.2	1	—	—	12	121	139	255	361
	LME	81625 N UU*	4	20	LME	81625 N UU AJ*	4	19	—		—	—																		
12	LME	122232 UU*	4	41.5	LME	122232 UU AJ*	4	40.5	LME	122232 UU OP*	3	32			22		32	0	22.9	0	1.3	21	1.5	7.5	78	12	259	298	503	711
	LME	122232 N UU*	4	40	LME	122232 N UU AJ*	4	39	LME	122232 N UU OP*	3	30																		
16	LME	162636 UU*	4	56.5	LME	162636 UU AJ*	4	55.5	LME	162636 UU OP*	3	48			26	- 9	36	-200	24.9	-200	1.3	24.9	1.5	10	78	12	283	325	514	726
	LME	162636 N UU*	4	55	LME	162636 N UU AJ*	4	54	LME	162636 N UU OP*	3	46																		
20	LME	203245 UU*	5	97	LME	203245 UU AJ*	5	96	LME	203245 UU OP*	4	84			32		45		31.5		1.6	30.3	2	10	60	12	562	668	1 010	1 470
	LME	203245 N UU*	5	91	LME	203245 N UU AJ*	5	90	LME	203245 N UU OP*	4	75																		
25	LME	254058 UU*	6	222	LME	254058 UU AJ*	6	219	LME	254058 UU OP*	5	195			40	0 -11	58		44.1		1.85	37.5	2	12.5	60	15	920	974	1 780	2 280
	LME	254058 N UU*(²)	6	215	LME	254058 N UU AJ*(²)	6	212	LME	254058 N UU OP*(²)	5	181																		
30	LME	304768 UU*	6	338	LME	304768 UU AJ*	6	333	LME	304768 UU OP*	5	309			47		68	0	52.1	0	1.85	44.5	2	12.5	50	12	1 350	1 430	2 500	3 200
	LME	304768 N UU*	6	325	LME	304768 N UU AJ*	6	320	LME	304768 N UU OP*	5	272																		
40	LME	406280 UU*	6	712	LME	406280 UU AJ*	6	701	LME	406280 UU OP*	5	665			62	0	80	-300	60.6	-300	2.15	59	3	16.8	50	17	2 030	2 150	3 620	4 640
	LME	406280 N UU*	6	705	LME	406280 N UU AJ*	6	694	LME	406280 N UU OP*	5	600																		
50	LME	5075100 UU*	6	1 147	LME	5075100 UU AJ*	6	1 127	LME	5075100 UU OP*	5	1 080			75	-13	100		77.6		2.65	72	3	21	50	17	3 940	4 180	7 130	9 120
	LME	5075100 N UU*	6	1 130	LME	5075100 N UU AJ*	6	1 110	LME	5075100 N UU OP*	5	970																		
60	LME	6090125 UU*	6	2 051	LME	6090125 UU AJ*	6	2 001	LME	6090125 UU OP*	5	1 900			90	0	125	0	101.7	0	3.15	86.5	3	27.2	54	20	4 760	5 040	8 150	10 400
	LME	6090125 N UU*	6	2 050	LME	6090125 N UU AJ*	6	2 000	LME	6090125 N UU OP*	5	1 580																		
80	LME80120165	UU*	6	5 030	LME80120165	UU AJ*	6	4 930	LME80120165	UU OP*	5	4 210			120	-15	165	-400	133.7	-400	4.15	116	3	36.3	54	20	8 710	9 220	14 500	18 500



Notes (¹) The width of hub for fixing with circlip should be the value obtained by subtracting a circlip width value times two from the C₁ dimension.

(²) The seal is slightly off from the external cylinder end.

Remarks 1. High carbon steel-made retainer (shaft diameter 8 mm), and standard type and adjustable clearance type (shaft diameter 12 mm to 60 mm) end plates are fixed with stop ring for holes.

2. The identification numbers with * are our semi-standard items.

IKO Linear Bushing Stainless Steel Made

	Standard type					Adjustable clearance type					Open type				
Shape	LM... F LM...N F					LM... FAJ LM...N FAJ					LM... F OP LM...N F OP				
															
Shaft diameter	6	8	10	12	13	6	8	10	12	13	—	—	10	12	13
	16	20	25	30	35	16	20	25	30	35	16	20	25	30	35
	40	50	60			40	50	60			40	50	60		

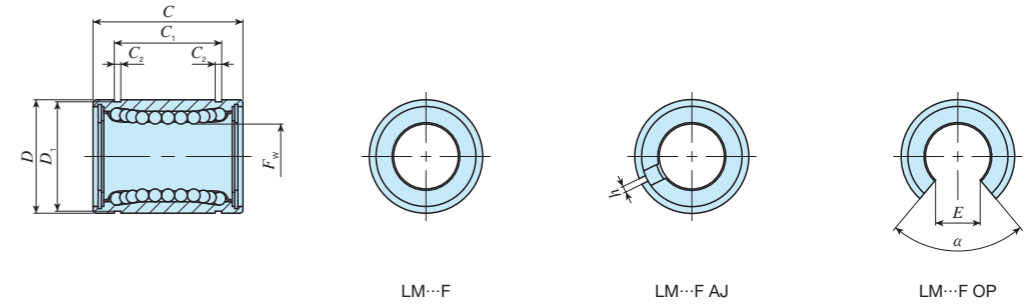

Shaft diameter mm	Identification number										Nominal dimensions and tolerances mm													Eccentricity		Basic dynamic load rating		Basic static load rating					
	Standard type		Ball raceway	Mass (Ref.) g	Adjustable clearance type		Ball raceway	Mass (Ref.) g	Open type		Ball raceway	Mass (Ref.) g	F _w	Dim. F _w tolerance μm		D	Dim. D tolerance μm	C	Dim. C tolerance μm	C ₁ (¹)	Dim. C ₁ tolerance μm	C ₂	D ₁	h	E	α	Maximum μm	P	H	Load direction A N	Load direction B N	Load direction A N	Load direction B N
	P	H	P	H	P	H	P	H	P	H	P	H		P	H																		
6	LM 61219 F	4	8	—	—	—	—	—	—	—	—	6			12		19		13.5		1.1	11.5	—	—	—					80.7	92.7	167	237
	LM 61219 N F	4	7.6	LM 61219 N F AJ*	4	7.5	—	—	—	—	—	8			15	0 -11	17		11.5		1.1	14.3	—	—	—					87.4	100	160	226
8	LM 81517 F	4	13	—	—	—	—	—	—	—	—	8			15		24		17.5		1.1	14.3	—	—	—					121	139	255	361
	LM 81524 F	4	18	—	—	—	—	—	—	—	—	8			15		24		17.5		1.1	14.3	—	—	—					121	139	255	361
10	LM 101929 F	4	30	—	—	—	—	—	—	—	—	10	0 -6	0 -9	19		29		22		1.3	18	—	—	—	8	12			179	206	354	501
	LM 101929 N F	4	27.5	LM 101929 N F AJ*	4	26.5	LM 101929 N F OP*	3	18	—	—	12			21	0	30	-200	23	-200	1.3	20	1.5	8	80					259	298	503	711
12	LM 122130 F	4	29	LM 122130 F AJ*	4	28	LM 122130 F OP*	3	19	—	—	12			21	0	30	-200	23	-200	1.3	20	1.5	8	80					259	298	503	711
	LM 122130 N F	4	31.5	LM 122130 N F AJ*	4	30.5	LM 122130 N F OP*	3	22	—	—	13			23	-13	32		23		1.3	22	1.5	9	80					266	306	506	716
13	LM 132332 F	4	43	LM 132332 F AJ*	4	42	LM 132332 F OP*	3	31	—	—	13			23		32		23		1.3	22	1.5	9	80					266	306	506	716
	LM 132332 N F	4	42.5	LM 132332 N F AJ*	4	41.5	LM 132332 N F OP*	3	31	—	—	16			28		37		26.5		1.6	27	1.5	11	80					426	489	766	1 080
16	LM 162837 F	4	70	LM 162837 F AJ*	4	69.5	LM 162837 F OP*	3	58	—	—	16			28		37		26.5		1.6	27	1.5	11	80					426	489	766	1 080
	LM 162837 N F	4	69	LM 162837 N F AJ*	4	68	LM 162837 N F OP*	3	52	—	—	20			32		42		30.5		1.6	30.5	1.5	11	60					562	668	1 010	1 470
20	LM 203242 F	5	92	LM 203242 F AJ*	5	91	LM 203242 F OP*	4	79	—	—	20			32		42		30.5		1.6	30.5	1.5	11	60					562	668	1 010	1 470
	LM 203242 N F	5	87	LM 203242 N F AJ*	5	85	LM 203242 N F OP*	4	69	—	—	25	0 -7	0 -10	40	0 -16	59		41		1.85	38	2	12	50	10	15			920	974	1 780	2 280
25	LM 254059 F	6	226	LM 254059 F AJ*	6	222	LM 254059 F OP*	5	203	—	—	25	0 -7	0 -10	40	0 -16	59		41		1.85	38	2	12	50	10	15			920	974	1 780	2 280
	LM 254059 N F	6	220	LM 254059 N F AJ*	6	216	LM 254059 N F OP*	5	188	—	—	30			45		64		44.5		1.85	43	2.5	15	50					1 350	1 430	2 500	3 200
30	LM 304564 F	6	253	LM 304564 F AJ*	6	250	LM 304564 F OP*	5	228	—	—	30			45		64		44.5		1.85	43	2.5	15	50					1 350	1 430	2 500	3 200
	LM 304564 N F	6	250	LM 304564 N F AJ*	6	245	LM 304564 N F OP*	5	210	—	—	35			52		70		49.5		2.1	49	2.5	17	50					1 610	1 710	3 080	3 940
35	LM 355270 F	6	387	LM 355270 F AJ*	6	380	LM 355270 F OP*	5	355	—	—	35			52		70		49.5		2.1	49	2.5	17	50					1 610	1 710	3 080	3 940
	LM 355270 N F	6	380	LM 355270 N F AJ*	6	375	LM 355270 N F OP*	5	335	—	—	40	0 -8	0 -12	60	0 -19	80	-300	60.5	-300	2.1	57	3	20	50	12	20			2 030	2 150	3 620	4 640
40	LM 406080 F	6	596	LM 406080 F AJ*	6	585	LM 406080 F OP*	5	546	—	—	40	0 -8	0 -12	60	0 -19	80	-300	60.5	-300	2.1	57	3	20	50	12	20			2 030	2 150	3 620	4 640
	LM 406080 N F	6	585	LM 406080 N F AJ*	6	579	LM 406080 N F OP*	5	500	—	—	50			80		100		74		2.6	76.5	3	25	50					3 940	4 180	7 130	9 120
50	LM 5080100 F	6	1 615	LM 5080100 F AJ*	6	1 595	LM 5080100 F OP*	5	1 420	—	—	50			80		100		74		2.6	76.5	3	25	50					3 940	4 180	7 130	9 120
	LM 5080100 N F	6	1 580	LM 5080100 N F AJ*	6	1 560	LM 5080100 N F OP*	5	1 340	—	—	60	0 -9	0 -15	90	0 -22	110		85		3.15	86.5	3	30	50	17	25			4 760	5 040	8 150	10 400
60	LM 6090110 F	6	1 817	LM 6090110 F AJ*	6	1 788	LM 6090110 F OP*	5	1 650	—	—	60	0 -9	0 -15	90	0 -22	110		85		3.15	86.5	3	30	50	17	25			4 760	5 040	8 150	10 400
	LM 6090110 N F	6	1 787	LM 6090110 N F AJ*	6	1 757	LM 6090110 N F OP*	5	1 610	—	—																						

Note (1) The width of hub for fixing with circlip should be the value obtained by subtracting a circlip width value times two from the C₁ dimension.

- Remarks 1. "P" and "H" in Dim. F_w tolerance and Eccentricity represent precision and high, respectively.
 2. Standard type and adjustable clearance type end plates are fixed with stop ring for holes.
 3. The identification numbers with * are our semi-standard items.

LMG • LM • LMS

IKO Linear Bushing Stainless Steel Made With Seal

Shape	Standard type					Adjustable clearance type					Open type				
	LM... F UU LM... N F UU					LM... F UU AJ LM... N F UU AJ					LM... F UU OP LM... N F UU OP				
Shaft diameter	6	8	10	12	13	6	8	10	12	13	—	—	10	12	13
	16	20	25	30	35	16	20	25	30	35	16	20	25	30	35
	40	50	60			40	50	60			40	50	60		

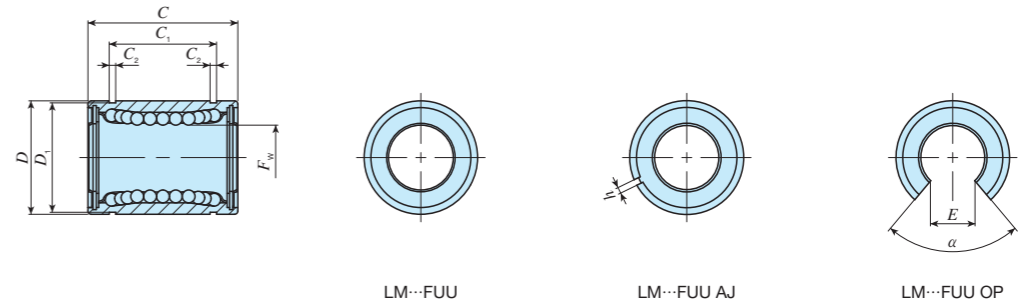

Shaft diameter mm	Identification number										Nominal dimensions and tolerances mm													Eccentricity		Basic dynamic load rating		Basic static load rating					
	Standard type		Ball raceway	Mass (Ref.) g	Adjustable clearance type		Ball raceway	Mass (Ref.) g	Open type		Ball raceway	Mass (Ref.) g	F _w	Dim. F _w tolerance μm		D	Dim. D tolerance μm	C	Dim. C tolerance μm	C ₁ ⁽¹⁾	Dim. C ₁ tolerance μm	C ₂	D ₁	h	E	α	Maximum μm	P	H	Load direction A N	Load direction B N	Load direction A N	Load direction B N
6	LM 61219 F UU	4	8	—	—	—	—	—	—	—	—	6			12		19		13.5		1.1	11.5	—	—	—				80.7	92.7	167	237	
	LM 61219 N F UU	4	7.6	LM 61219 N F UU AJ*	4	7.5	—	—	—	—	—	8			15	0 -11	17		11.5		1.1	14.3	—	—	—				87.4	100	160	226	
8	LM 81517 F UU	4	13	—	—	—	—	—	—	—	—	8			15		24		17.5		1.1	14.3	—	—	—				121	139	255	361	
	LM 81524 F UU	4	18	—	—	—	—	—	—	—	—	8			15		24		17.5		1.1	14.3	—	—	—				121	139	255	361	
10	LM 101929 F UU	4	30	—	—	—	—	—	—	—	—	10	0 -6	0 -9	19		29		22		1.3	18	—	—	—	8	12		179	206	354	501	
	LM 101929 N F UU	4	27.5	LM 101929 N F UU AJ*	4	26.5	LM 101929 N F UU OP*	3	18	—	—	10			19		29		22		1.3	18	—	—	—	8	12		179	206	354	501	
12	LM 122130 F UU	4	29	LM 122130 F UU AJ*	4	28	LM 122130 F UU OP*	3	19	—	—	12			21	0 -13	30	-200	23	-200	1.3	20	1.5	8	80			259	298	503	711		
	LM 122130 N F UU	4	31.5	LM 122130 N F UU AJ*	4	30.5	LM 122130 N F UU OP*	3	22	—	—	12			21		30		23		1.3	20	1.5	8	80			259	298	503	711		
13	LM 132332 F UU	4	43	LM 132332 F UU AJ*	4	42	LM 132332 F UU OP*	3	31	—	—	13			23		32		23		1.3	22	1.5	9	80			266	306	506	716		
	LM 132332 N F UU	4	42.5	LM 132332 N F UU AJ*	4	41.5	LM 132332 N F UU OP*	3	31	—	—	13			23		32		23		1.3	22	1.5	9	80			266	306	506	716		
16	LM 162837 F UU	4	70	LM 162837 F UU AJ*	4	69.5	LM 162837 F UU OP*	3	58	—	—	16			28		37		26.5		1.6	27	1.5	11	80			426	489	766	1 080		
	LM 162837 N F UU	4	69	LM 162837 N F UU AJ*	4	68	LM 162837 N F UU OP*	3	52	—	—	16			28		37		26.5		1.6	27	1.5	11	80			426	489	766	1 080		
20	LM 203242 F UU	5	92	LM 203242 F UU AJ*	5	91	LM 203242 F UU OP*	4	79	—	—	20			32		42		30.5		1.6	30.5	1.5	11	60			562	668	1 010	1 470		
	LM 203242 N F UU	5	87	LM 203242 N F UU AJ*	5	85	LM 203242 N F UU OP*	4	69	—	—	20			32		42		30.5		1.6	30.5	1.5	11	60			562	668	1 010	1 470		
25	LM 254059 F UU	6	226	LM 254059 F UU AJ*	6	222	LM 254059 F UU OP*	5	203	—	—	25	0 -7	0 -10	40	0 -16	59		41		1.85	38	2	12	50	10	15		920	974	1 780	2 280	
	LM 254059 N F UU	6	220	LM 254059 N F UU AJ*	6	216	LM 254059 N F UU OP*	5	188	—	—	25			40		59		41		1.85	38	2	12	50	10	15		920	974	1 780	2 280	
30	LM 304564 F UU	6	253	LM 304564 F UU AJ*	6	250	LM 304564 F UU OP*	5	228	—	—	30			45		64		44.5		1.85	43	2.5	15	50			1 350	1 430	2 500	3 200		
	LM 304564 N F UU	6	250	LM 304564 N F UU AJ*	6	245	LM 304564 N F UU OP*	5	210	—	—	30			45		64		44.5		1.85	43	2.5	15	50			1 350	1 430	2 500	3 200		
35	LM 355270 F UU	6	387	LM 355270 F UU AJ*	6	380	LM 355270 F UU OP*	5	355	—	—	35			52		70		49.5		2.1	49	2.5	17	50			1 610	1 710	3 080	3 940		
	LM 355270 N F UU	6	380	LM 355270 N F UU AJ*	6	375	LM 355270 N F UU OP*	5	335	—	—	35			52		70		49.5		2.1	49	2.5	17	50			1 610	1 710	3 080	3 940		
40	LM 406080 F UU	6	596	LM 406080 F UU AJ*	6	585	LM 406080 F UU OP*	5	546	—	—	40	0 -8	0 -12	60	0 -19	80	-300	60.5	-300	2.1	57	3	20	50	12	20		2 030	2 150	3 620	4 640	
	LM 406080 N F UU	6	585	LM 406080 N F UU AJ*	6	579	LM 406080 N F UU OP*	5	500	—	—	40			60		80		60.5		2.1	57	3	20	50	12	20		2 030	2 150	3 620	4 640	
50	LM 5080100 F UU	6	1 615	LM 5080100 F UU AJ*	6	1 595	LM 5080100 F UU OP*	5	1 420	—	—	50			80		100		74		2.6	76.5	3	25	50			3 940	4 180	7 130	9 120		
	LM 5080100 N F UU	6	1 580	LM 5080100 N F UU AJ*	6	1 560	LM 5080100 N F UU OP*	5	1 340	—	—	50			80		100		74		2.6	76.5	3	25	50			3 940	4 180	7 130	9 120		
60	LM 6090110 F UU	6	1 817	LM 6090110 F UU AJ*	6	1 788	LM 6090110 F UU OP*	5	1 650	—	—	60	0 -9	0 -15	90	0 -22	110		85		3.15	86.5	3	30	50	17	25		4 760	5 040	8 150	10 400	
	LM 6090110 N F UU	6	1 787	LM 6090110 N F UU AJ*	6	1 757	LM 6090110 N F UU OP*	5	1 610	—	—	60			90		110		85		3.15	86.5	3	30	50	17	25		4 760	5 040	8 150	10 400	

Note (1) The width of hub for fixing with circlip should be the value obtained by subtracting a circlip width value times two from the C₁ dimension.



Remarks 1. "P" and "H" in Dim. F_w tolerance and Eccentricity represent precision and high, respectively.

2. Standard type and adjustable clearance type end plates are fixed with stop ring for holes.

3. The identification numbers with * are our semi-standard items.

LMG • LM • LMS

IKO Linear Bushing Stainless Steel Made

	Standard type					Adjustable clearance type					Open type				
Shape	LME... F LME... N F					LME... F AJ LME... N F AJ					LME... F OP LME... N F OP				
															
Shaft diameter	5	8	12	16	20	5	8	12	16	20	—	—	12	16	20
	25	30	40	50	60	25	30	40	50	60	25	30	40	50	60

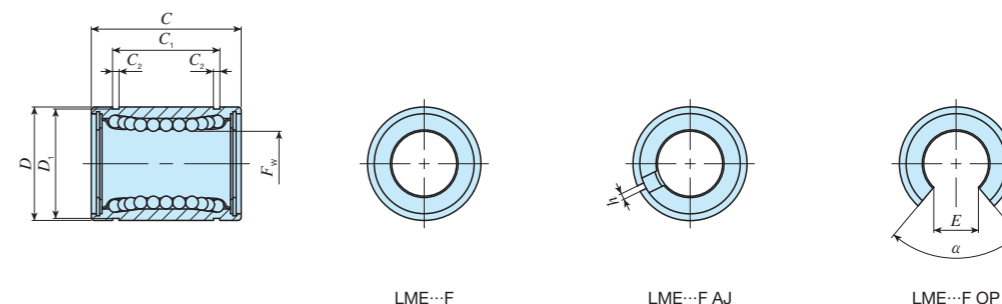



Shaft diameter mm	Identification number										Nominal dimensions and tolerances mm													Eccentricity Maximum μm	Basic dynamic load rating C		Basic static load rating C ₀			
	Standard type		Ball raceway	Mass (Ref.) g	Adjustable clearance type		Ball raceway	Mass (Ref.) g	Open type		Ball raceway	Mass (Ref.) g	F _w	Dim. F _w tolerance μm	D	Dim. D tolerance μm	C	Dim. C tolerance μm	C ₁ (¹)	Dim. C ₁ tolerance μm	C ₂	D ₁	h		E	α	Load direction A N	Load direction B N	Load direction A N	Load direction B N
5	LME 51222 N F*	F*	4	11	LME 51222 N F AJ*	F AJ*	4	9.5	—	—	—	5		12	0	22	0	14.5	0	1.1	11.5	1	—	—	12	90.8	104	219	310	
8	LME 81625 F*	F*	4	20	—	—	—	—	—	—	—	8	+8 0	16	-8	25	0	16.5	0	1.1	15.2	—	—	—	12	121	139	255	361	
	LME 81625 N F*	F*	4	20	LME 81625 N F AJ*	F AJ*	4	19.5	—	—	—																			
12	LME 122232 F*	F*	4	41.5	LME 122232 F AJ*	F AJ*	4	40.5	LME 122232 F OP*	F OP*	3	32	12		22	0	32	0	22.9	0	1.3	21	1.5	7.5	78	12	259	298	503	711
	LME 122232 N F*	F*	4	40	LME 122232 N F AJ*	F AJ*	4	39	LME 122232 N F OP*	F OP*	3	30																		
16	LME 162636 F*	F*	4	56.5	LME 162636 F AJ*	F AJ*	4	55.5	LME 162636 F OP*	F OP*	3	48	16	+9 -1	26	-9	36	-200	24.9	-200	1.3	24.9	1.5	10	78	12	283	325	514	726
	LME 162636 N F*	F*	4	55	LME 162636 N F AJ*	F AJ*	4	54	LME 162636 N F OP*	F OP*	3	46																		
20	LME 203245 F*	F*	5	97	LME 203245 F AJ*	F AJ*	5	96	LME 203245 F OP*	F OP*	4	84	20		32		45		31.5		1.6	30.3	2	10	60	12	562	668	1 010	1 470
	LME 203245 N F*	F*	5	91	LME 203245 N F AJ*	F AJ*	5	90	LME 203245 N F OP*	F OP*	4	75																		
25	LME 254058 F*	F*	6	222	LME 254058 F AJ*	F AJ*	6	219	LME 254058 F OP*	F OP*	5	195	25	+11 -1	40	0	58		44.1		1.85	37.5	2	12.5	60	15	920	974	1 780	2 280
	LME 254058 N F*	F*	6	215	LME 254058 N F AJ*	F AJ*	6	212	LME 254058 N F OP*	F OP*	5	181																		
30	LME 304768 F*	F*	6	338	LME 304768 F AJ*	F AJ*	6	333	LME 304768 F OP*	F OP*	5	309	30		47		68	0	52.1	0	1.85	44.5	2	12.5	50	17	1 350	1 430	2 500	3 200
	LME 304768 N F*	F*	6	325	LME 304768 N F AJ*	F AJ*	6	320	LME 304768 N F OP*	F OP*	5	272																		
40	LME 406280 F*	F*	6	712	LME 406280 F AJ*	F AJ*	6	701	LME 406280 F OP*	F OP*	5	665	40		62	0	80	-300	60.6	-300	2.15	59	3	16.8	50	17	2 030	2 150	3 620	4 640
	LME 406280 N F*	F*	6	705	LME 406280 N F AJ*	F AJ*	6	694	LME 406280 N F OP*	F OP*	5	600																		
50	LME 5075100 F*	F*	6	1 147	LME 5075100 F AJ*	F AJ*	6	1 127	LME 5075100 F OP*	F OP*	5	1 080	50	+13 -2	75	-13	100		77.6		2.65	72	3	21	50	17	3 940	4 180	7 130	9 120
	LME 5075100 N F*	F*	6	1 130	LME 5075100 N F AJ*	F AJ*	6	1 110	LME 5075100 N F OP*	F OP*	5	970																		
60	LME 6090125 F*	F*	6	2 051	LME 6090125 F AJ*	F AJ*	6	2 001	LME 6090125 F OP*	F OP*	5	1 900	60		90	0	125	0	101.7	0	3.15	86.5	3	27.2	54	20	4 760	5 040	8 150	10 400
	LME 6090125 N F*	F*	6	2 050	LME 6090125 N F AJ*	F AJ*	6	2 000	LME 6090125 N F OP*	F OP*	5	1 580																		

Note (1) The width of hub for fixing with circlip should be the value obtained by subtracting a circlip width value times two from the C₁ dimension.

- Remarks 1. Stainless steel-made retainer (shaft diameter 8 mm), and standard type and adjustable clearance type (shaft diameter 12 mm to 60 mm) end plates are fixed with stop ring for holes.
2. The identification numbers with * are our semi-standard items.

LMG • LM • LMS

IKO Linear Bushing Stainless Steel Made With Seal

	Standard type					Adjustable clearance type					Open type									
Shape	LME... F UU LME... N F UU					LME... F UU AJ LME... N F UU AJ					LME... F UU OP LME... N F UU OP									
																				
Shaft diameter	5	8	12	16	20	5	8	12	16	20	—	—	12	16	20	25	30	40	50	60

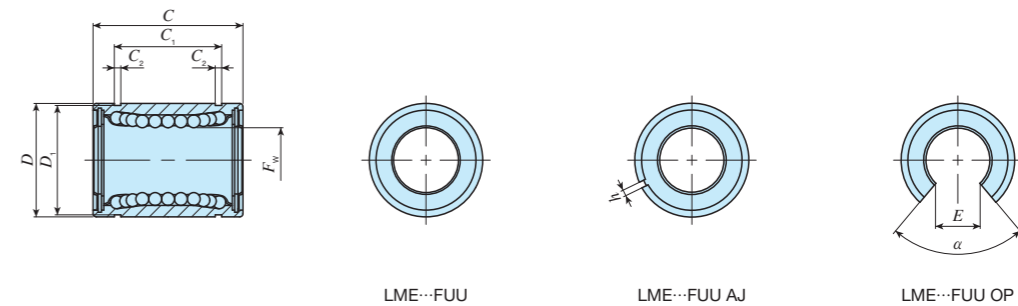

Shaft diameter mm	Identification number										Nominal dimensions and tolerances mm													Eccentricity Maximum μm	Basic dynamic load rating C		Basic static load rating C ₀			
	Standard type		Ball raceway	Mass (Ref.) g	Adjustable clearance type		Ball raceway	Mass (Ref.) g	Open type		Ball raceway	Mass (Ref.) g	F _w	Dim. Fw tolerance μm	D	Dim. D tolerance μm	C	Dim. C tolerance μm	C ₁ (¹)	Dim. C ₁ tolerance μm	C ₂	D ₁	h		E	α Degree	Load direction A N	Load direction B N	Load direction A N	Load direction B N
5	LME 51222 N F UU*	4	11	LME 51222 N F UU AJ*	4	9.5	—	—	—	—	—	5		12	0	22		14.5		1.1	11.5	1	—	—	12	90.8	104	219	310	
8	LME 81625 F UU*	4	20	—	—	—	—	—	—	—	—	8	+ 8 0	16	- 8	25		16.5		1.1	15.2	—	—	—	12	121	139	255	361	
	LME 81625 N F UU*	4	20	LME 81625 N F UU AJ*	4	19.5	—	—	—	—	—																			
12	LME 122232 F UU*	4	41.5	LME 122232 F UU AJ*	4	40.5	LME 122232 F UU OP*	3	32	3	32	12		22	0	32	0	22.9	0	1.3	21	1.5	7.5	78	12	259	298	503	711	
	LME 122232 N F UU*	4	40	LME 122232 N F UU AJ*	4	39	LME 122232 N F UU OP*	3	30	3	30																			
16	LME 162636 F UU*	4	56.5	LME 162636 F UU AJ*	4	55.5	LME 162636 F UU OP*	3	48	3	48	16	+ 9 - 1	26	- 9	36	- 200	24.9	- 200	1.3	24.9	1.5	10	78	12	283	325	514	726	
	LME 162636 N F UU*	4	55	LME 162636 N F UU AJ*	4	54	LME 162636 N F UU OP*	3	46	3	46																			
20	LME 203245 F UU*	5	97	LME 203245 F UU AJ*	5	96	LME 203245 F UU OP*	4	84	4	84	20		32		45		31.5		1.6	30.3	2	10	60	12	562	668	1 010	1 470	
	LME 203245 N F UU*	5	91	LME 203245 N F UU AJ*	5	90	LME 203245 N F UU OP*	4	75	4	75																			
25	LME 254058 F UU*	6	222	LME 254058 F UU AJ*	6	219	LME 254058 F UU OP*	5	195	5	195	25	+ 11 - 1	40	0	58		44.1		1.85	37.5	2	12.5	60	15	920	974	1 780	2 280	
	LME 254058 N F UU*(²)	6	215	LME 254058 N F UU AJ*(²)	6	212	LME 254058 N F UU OP*(²)	5	181	5	181																			
30	LME 304768 F UU*	6	338	LME 304768 F UU AJ*	6	333	LME 304768 F UU OP*	5	309	5	309	30		47		68	0	52.1	0	1.85	44.5	2	12.5	50	12	1 350	1 430	2 500	3 200	
	LME 304768 N F UU*	6	325	LME 304768 N F UU AJ*	6	320	LME 304768 N F UU OP*	5	272	5	272																			
40	LME 406280 F UU*	6	712	LME 406280 F UU AJ*	6	701	LME 406280 F UU OP*	5	665	5	665	40		62	0	80	- 300	60.6	- 300	2.15	59	3	16.8	50	17	2 030	2 150	3 620	4 640	
	LME 406280 N F UU*	6	705	LME 406280 N F UU AJ*	6	694	LME 406280 N F UU OP*	5	600	5	600																			
50	LME 5075100 F UU*	6	1 147	LME 5075100 F UU AJ*	6	1 127	LME 5075100 F UU OP*	5	1 080	5	1 080	50	+ 13 - 2	75	- 13	100		77.6		2.65	72	3	21	50	12	3 940	4 180	7 130	9 120	
	LME 5075100 N F UU*	6	1 130	LME 5075100 N F UU AJ*	6	1 110	LME 5075100 N F UU OP*	5	970	5	970																			
60	LME 6090125 F UU*	6	2 051	LME 6090125 F UU AJ*	6	2 001	LME 6090125 F UU OP*	5	1 900	5	1 900	60		90	0	125	- 400	101.7	0	3.15	86.5	3	27.2	54	20	4 760	5 040	8 150	10 400	
	LME 6090125 N F UU*	6	2 050	LME 6090125 N F UU AJ*	6	2 000	LME 6090125 N F UU OP*	5	1 580	5	1 580																			

Notes (¹) The width of hub for fixing with circlip should be the value obtained by subtracting a circlip width value times two from the C₁ dimension.

(²) The seal is slightly off from the external cylinder end.

Remarks 1. Stainless steel-made retainer (shaft diameter 8 mm), and standard type and adjustable clearance type (shaft diameter 12 mm to 60 mm) end plates are fixed with stop ring for holes.

2. The identification numbers with * are our semi-standard items.

LMG • LM • LMS

Miniature Linear Bushing

LMS

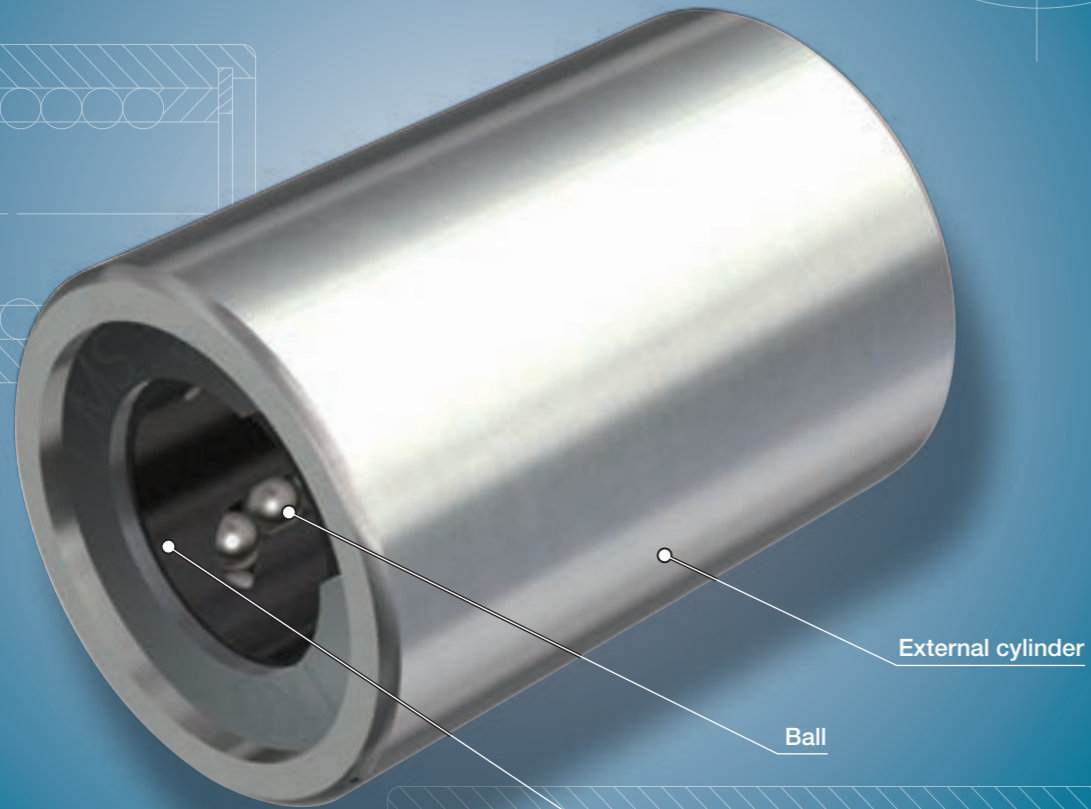
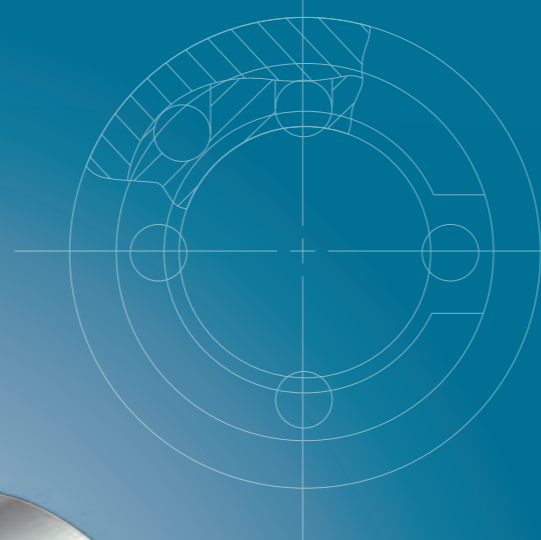

Points

1 Compact design

The ultra-small size allows for compact machine and device design.

2 Wide variation

As the lineup of two types of external cylinder length are available, i.e. standard and long, you can select an optimal linear bushing for the specifications of your machine and device.

3 Stainless steel selections for excellent corrosion resistance

Products made of stainless steel are highly resistant to corrosion, so that they are suitable for applications where rust prevention oil is not preferred, such as in a cleanroom environment.

Identification Number and Specification

Example of an identification number

The specification of LMS series is indicated by the identification number. Indicate the identification number, consisting of a model code, dimensions, a material code, a part code, and a classification symbol for each specification to apply.

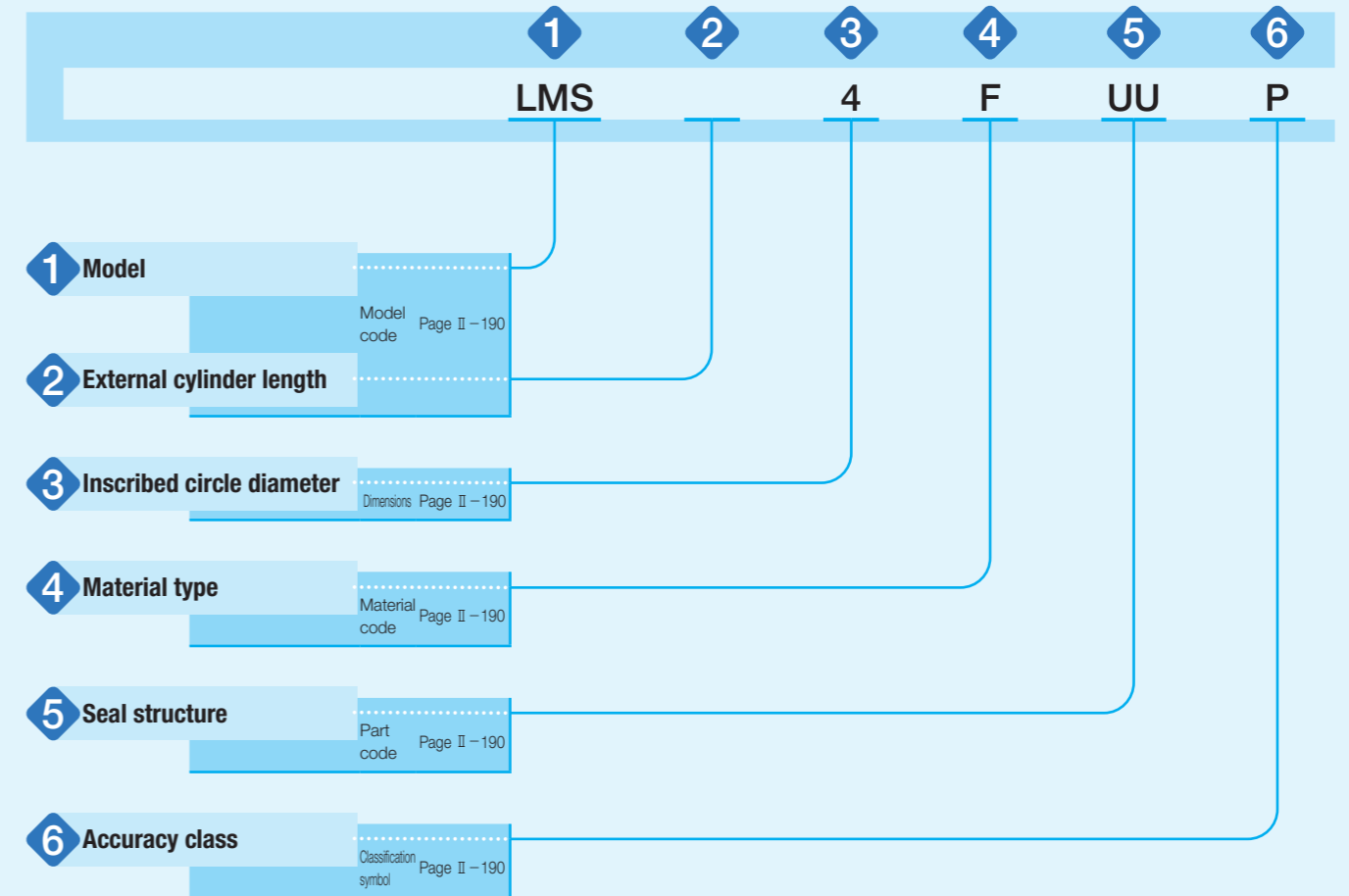

Identification Number and Specification

1 Model	Miniature Linear Bushing (LMS series)	: LMS	
For applicable models and sizes, see Table 1.			
2 External cylinder length	Standard Long	: No symbol : L	
3 Inscribed circle diameter	Indicate the inscribed circle diameter in mm.		
4 Material type	High carbon steel made Stainless steel made	: No symbol : F	Specify the component part material. For applicable models and sizes, see Table 1.
5 Seal structure	Without seal With two end seals	: No symbol : UU	The models with two end seals incorporate seals with superior dust protection performance for preventing intrusion of foreign substances.
6 Accuracy class	High Precision	: No symbol : P	For details of accuracy, see the dimension table on page II-192. Precision applies only to the standard type. Especially when it is necessary to control clearance with the shaft strictly, the tolerance of inscribed circle diameter can be sorted by 0.002 mm before delivery. Contact IKO for further information.

Table 1 Models and sizes of LMS series

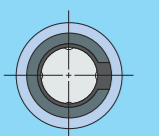
Shape	External cylinder length	Material type	Seal structure	Model	Size		
					3	4	5
	Standard	High carbon steel made	Without seal	LMS	○	○	○
			With two end seals	LMS...UU	○	○	○
		Stainless steel made	Without seal	LMS...F	○	○	○
			With two end seals	LMS...FUU	○	○	○
	Long	High carbon steel made	Without seal	LMSL	○	○	○
			With two end seals	LMSL...UU	○	○	○
		Stainless steel made	Without seal	LMSL...F	○	○	○
			With two end seals	LMSL...FUU	○	○	○

Relationship between Load Rating and Ball Raceway

The load rating of LMS series varies according to the loading direction and position of ball raceway. The dimension table describes two types of values shown in Fig. 1.1 and Fig. 1.2 according to the loading direction and position of ball raceway.

Fig. 1.1 shows the case where the loading direction and ball raceway position coincides with each other, representing the loading direction A in the dimension table. Generally, this is applied when the ball raceway position cannot be specified to indeterminate direction load or loading direction.

Fig. 1.2 shows the case where the loading direction is positioned between ball raceways, representing the loading direction B in the dimension table. Generally, this can be subjected to load bigger than loading direction A.

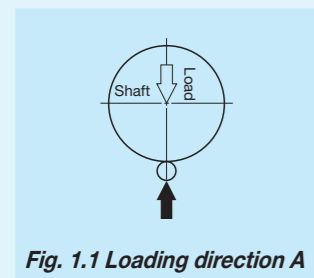

Fig. 1.1 Loading direction A

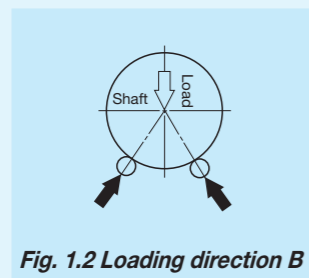

Fig. 1.2 Loading direction B

Lubrication

Grease is not pre-packed in the LMS series, so please perform adequate lubrication as needed.

Both of oil lubrication and grease lubrication are available in the LMS series. For grease lubrication, it is typically applied lightly to the shaft and each row. Use of high-quality lithium-soap base grease is recommended for the grease to use.

Related Products

Shaft for Miniature Linear Bushing

To make full use of performance of the LMS series, we also offer shaft with high accuracy for Miniature Linear Bushing grounded after heat treatment. If you are interested, contact **IKO**.

Precaution for Use

1 Fitting of external cylinder

Recommended fit for the LMS series is indicated in Table 2. As the external cylinder is thin, use epoxy type adhesive agent for fixing to the housing hole, instead of press-fitting.

Table 2 Recommended fit
(Tolerances of dimensions for shaft and housing hole) unit: μm

Accuracy class	Item	Shaft	Housing hole
High		-6	+12
		-14	0
Precision		-4	+8
		-9	0

2 Raceway

LMS series operates with a shaft as a raceway surface, the shaft should be heat-treated and ground. Recommended surface hardness, roughness, and minimum effective hardening depth of shaft are indicated in Table 3.

Table 3 Surface hardness, roughness, and effective hardening depth of shaft

Item	Recommended value	Remark
Surface hardness	58~64HRC	When the surface hardness is low, multiply the load rating by hardness factor ⁽¹⁾ .
Surface roughness	0.2 μmRa or lower (0.8 μmRy or lower)	-
Effective hardening depth	0.8 mm or higher	-

Note ⁽¹⁾ For hardness factor, refer to Fig. 3 in page III-5.

3 When accompanied by rotational motion

LMS series units support only linear motion but do not support rotational motion. When performing rotational motion and linear motion of short stroke length, **IKO** Miniature Stroke Rotary Bushing is recommended to be used.

4 Insertion of shaft

When inserting a shaft to the external cylinder, be careful not to let the shaft pried open as it may cause dropping of balls or deformation of the retainer.

5 Operating temperature

The maximum operating temperature is 120°C and temperature up to 100°C is allowed for continuous operation. When the temperature exceeds 100°C, contact **IKO**.

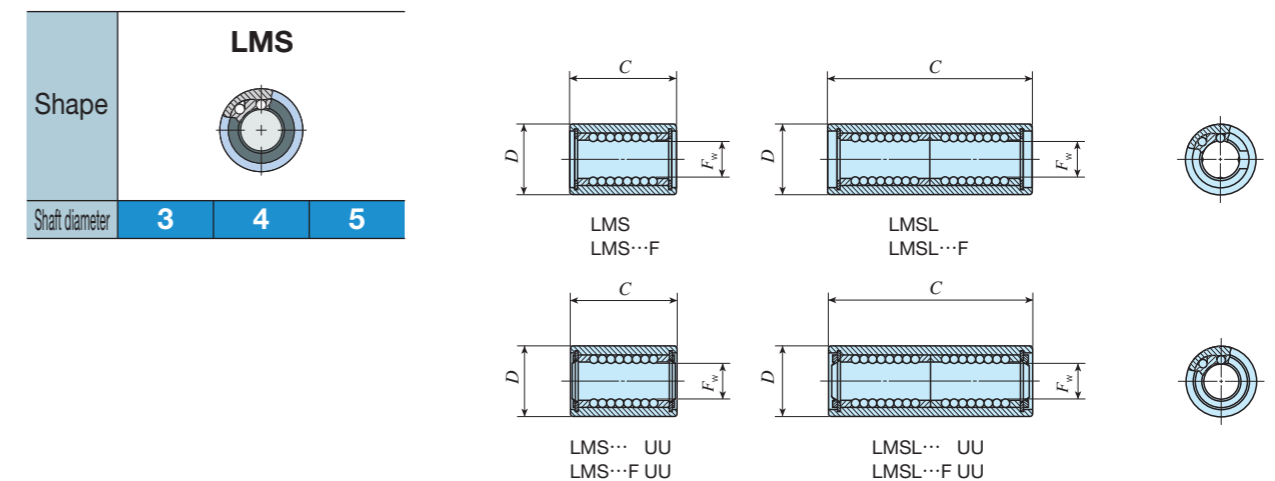

Shaft diameter mm	Identification number	Ball raceway	Mass (Ref.) g	Nominal dimensions and tolerances mm							Eccentricity		Basic dynamic load rating		Basic static load rating	
				Dim. F_w tolerance		Dim. D tolerance		C	Dim. C tolerance	Maximum		C		C_0		
				μm	μm	μm	μm			μm	μm	Load direction A	Load direction B	Load direction A	Load direction B	
3	LMS 3	4	1.8	3	7	0	0	10	0	2	4	18.4	21.2	39.4	55.8	
	LMS 3 F															
	LMS 3 UU															
	LMS 3 F UU															
	LMSL 3															
	LMSL 3 F															
LMSL 3 UU																
LMSL 3 F UU																
4	LMS 4	4	2.8	4	8	0	0	12	0	2	4	23.5	27.0	48.6	68.7	
	LMS 4 F															
	LMS 4 UU															
	LMS 4 F UU															
	LMSL 4															
	LMSL 4 F															
LMSL 4 UU																
LMSL 4 F UU																
5	LMS 5	4	3.8	5	10	0	0	15	0	2	4	51.3	59.0	108	152	
	LMS 5 F															
	LMS 5 UU															
	LMS 5 F UU															
	LMSL 5															
	LMSL 5 F															
LMSL 5 UU																
LMSL 5 F UU																

Remark: "P" and "H" in Dim. F_w tolerance and Eccentricity represent precision and high, respectively.

Stroke Rotary Bushing

Stroke Rotary Bushing
Miniature Stroke Rotary Bushing
Stroke Rotary Cage



Stroke Rotary Bushing

ST



Points

● Rotational and linear motions

With the combination of an external cylinder with cylindrical raceway and balls incorporated in the retainer, rotary and linear motion in the axial direction is possible simultaneously with rotational motion.

● Small inertia

The retainer has a high rigidity and light weight so that it has small motion inertia suitable for rolling motion and reciprocal motion in the high-speed operation.

● Small rolling frictional resistance

By building a ball with high accuracy into the precisely polished external cylinder, a small rolling frictional resistance and extremely smooth rolling motion together with reciprocal motion have been achieved.

● Wide variation

Ordinary type and heavy load type with different load rating are provided, and each are available with and without seals. You can select an optimal linear bushing for the specifications of your machine and device.

Identification Number and Specification

Example of an identification number

The specification of ST series is indicated by the identification number. Indicate the identification number, consisting of a model code, dimensions and a part code for each specification to apply.

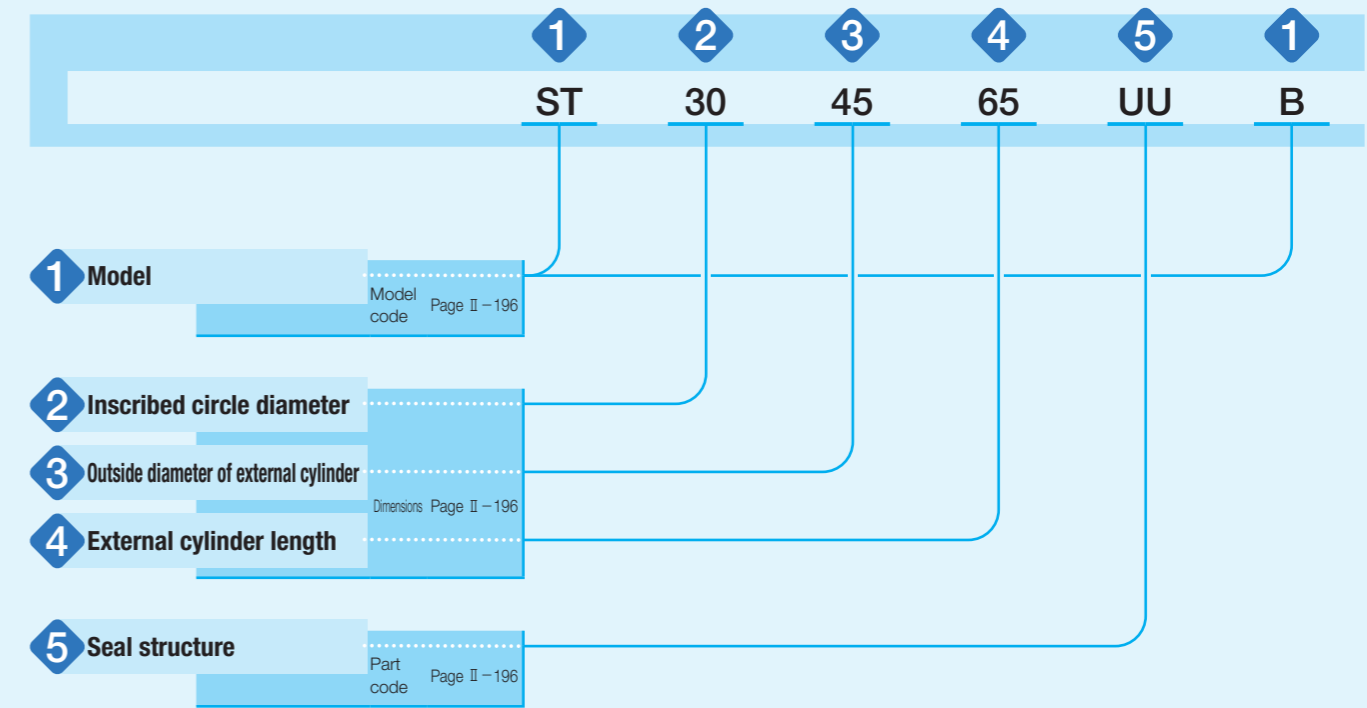



Identification Number and Specification

1 Model	Stroke Rotary Bushing (ST series)	Ordinary type : ST	Heavy load type : ST...B
	For applicable models and sizes, see Table 1.		
2 Inscribed circle diameter		Indicate the inscribed circle diameter in mm.	
3 Outside diameter of external cylinder		Indicate the outside diameter of external cylinder in mm.	
4 External cylinder length		Indicate the external cylinder length in mm.	
5 Seal structure	Open type	: No symbol	The models with seal type incorporate seals with superior dust protection performance for preventing intrusion of foreign substances.
	With seal	: UU	

ST • STSI • BG

Identification Number and Specification

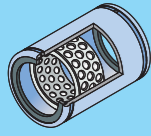
Table 1 Models and sizes of ST series

Shape	Seal structure	Model	Size																		
			4	5	6	8	10	12	16	20	25	30	35	40	45	50	55	60	70	80	90
 Ordinary type	Open type	ST	○	○	○	○	○	○	○	○	○	○	○	○	○	○	○	○	○	○	○
	With seal	ST...UU	-	-	-	○	○	○	○	○	○	○	○	○	○	○	○	○	○	○	○
 Heavy load type	Open type	ST...B	-	-	-	○	○	○	○	○	○	○	○	○	○	○	○	○	○	○	○
	With seal	ST...UUB	-	-	-	-	-	-	-	-	-	○	○	○	○	○	○	○	○	○	○

Accuracy

Since outside diameter of external cylinder is deformed by stop ring tension, calculate the measurement point from the equation (1) and use the average diameter value at the point.

$$W = 4 + L_1 / 8 \dots \dots \dots (1)$$

where, W: Distance from the end to measurement point P, mm (see Fig. 1)

L_1 : External cylinder length, mm

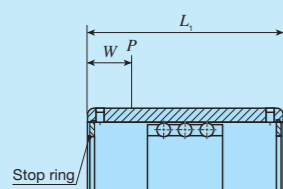

Fig. 1

Table 2 Tolerance of inscribed circle diameter and outside diameter of external cylinder unit: μm

Nominal dimensions of inscribed circle diameter F_w or outside diameter of external cylinder D mm	Tolerance of inscribed circle diameter F_w		Tolerance of outside diameter of external cylinder D_m (1)		
	Over	Incl.	High	Low	High
4	6	+18	+10	-	-
6	10	+22	+13	0	- 8
10	18	+27	+16	0	- 8
18	30	+33	+20	0	- 9
30	50	+41	+25	0	-11
50	80	+49	+30	0	-13
80	120	+58	+36	0	-15
120	150	-	-	0	-18

Note (1) D_m is an arithmetic mean value of the maximum diameter and minimum diameter obtained by two-point measurement of the outside diameter of external cylinder.

Table 3 Tolerance of external cylinder length unit: μm

Nominal dimensions of inscribed circle diameter F_w mm		Dim. L_1 tolerance of external cylinder length	
Over	Incl.	High	Low
-	20	0	-200
20	60	0	-300
60	100	0	-400

Allowance of Velocity

The ST series is capable of rotation and rotary and linear motion. However, allowance of velocity for these motions performed at the same time is obtained from the equation (2). Typical values are indicated in Table 4.

$$DN \geq D_{pw} n + 10 S n_1 \dots \dots \dots (2)$$

where, DN : Allowance of velocity (see Table 4)

n : Rotational speed, rpm

n_1 : Number of strokes per minute, cpm

S : Stroke length, mm

D_{pw} : Pitch circle diameter of balls, mm ($D_{pw} \doteq 1.15F_w$)

F_w : Inscribed circle diameter, mm

However, applicable when $n_1 \leq 5000$, $S n_1 \leq 50000$.

Table 4 Allowance of velocity

Lubrication conditions	DN
Oil lubrication	600 000
Grease lubrication	300 000

Lubrication

Grease is not pre-packed in the ST series, so please perform adequate lubrication as needed.

Both of oil lubrication and grease lubrication are available in the ST series. For grease lubrication, use of high-quality lithium-soap base grease is recommended. Oil is fed from

the oil hole on the external cylinder.

Precaution for Use

1 Fitting

Recommended fit for the ST series is indicated in Table 5. As the ST series performs rotation and rotary and linear motion at the same time, the radial internal clearance must be smaller when shock load or load accompanied by vibration is applied. Especially when vertical axis application or high accuracy motion is required, it is recommended to set the radial internal clearance at zero or under a slightly-preloaded condition.

Excessive preload will shorten the life, so be careful not to set lower limit value of radial internal clearance below the value stated in Table 6.

Table 5 Recommended fit

Operational conditions	Tolerance class	
	Shaft	Housing hole
Normal operational conditions	k5, m5	H6, H7
For vertical axis or high accuracy	n5, p6	J6, J7

Table 6 Lower limit of radial internal clearance unit: μm

Nominal dimensions of inscribed circle diameter F_w mm		Lower limit of radial internal clearance
Over	Incl.	
4	6	- 2
6	10	- 3
10	18	- 4
18	30	- 5
30	50	- 6
50	80	- 8
80	100	-10

2 Raceway

Since ST series operates with a shaft as a raceway surface, the shaft should be heat-treated and ground. Recommended values for surface hardness and roughness of the shaft are shown in Table 7 and the recommended value for the minimum effective hardening depth is shown in Table 8.

Table 7 Surface hardness and roughness of raceway

Item	Recommended value	Remark
Surface hardness	58~64HRC	When the surface hardness is low, multiply the load rating by hardness factor (1).
Surface roughness	0.2 μmRa or lower (0.8 μmRy or lower)	Where accuracy standard is low, around 0.8 μmRa (3.2 μmRy) is also allowed.

Note (1) For hardness factor, refer to Fig. 3 in page III-5.

Table 8 Minimum effective hardening depth of shaft unit: mm

Shaft diameter		Recommended value for minimum effective hardening depth
Over	Incl.	
-	28	0.8
28	50	1.0
50	100	1.5

3 Stroke length

For stroke length used, 80% of the maximum stroke length stated in the dimension table is recommended.

4 Operating temperature

The maximum operating temperature is 120°C and temperature up to 100°C is allowed for continuous operation. When the temperature exceeds 100°C, contact **IKO**.

5 Assembly operation of external cylinder and shaft

When inserting a shaft, be careful not to shock the ball. After assembling, correct the position of the retainer to be in the center of the external cylinder. After assembling the external cylinder to the housing, insert the shaft softly. Move the retainer as well as the shaft until they contact one side of the surface and stop. Then push the shaft not to damage balls or raceway to the position a half of the maximum stroke length and return it by the same length (a half of the maximum stroke) so that the retainer is positioned regularly at the center of the external cylinder.

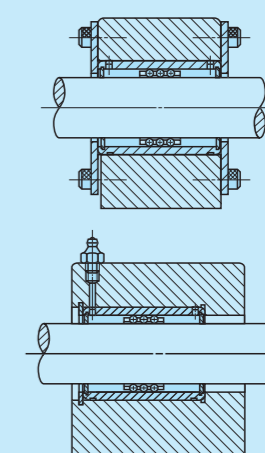
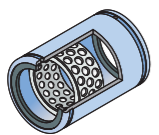
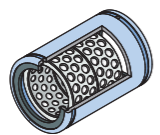
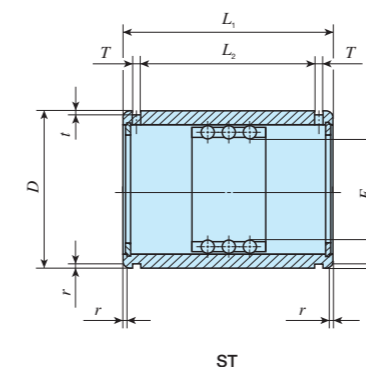

Fig. 2 Mounting examples

IKO Stroke Rotary Bushing **Open Type**

	Ordinary type								Heavy load type																			
Shape	ST								ST...B																			
																												
Size	4	5	6	8	10	12	16	—	—	—	8	10	12	16	20	25	30	35	40	45	50	20	25	30	35	40	45	50
	55	60	70	80	90	100	—	—	—	55	60	70	80	90	100	—	—	—	—	—	—	—	55	60	70	80	90	100



ST

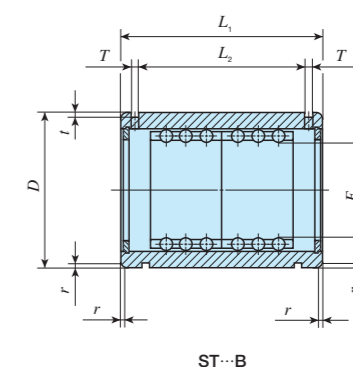

ST...B

Shaft diameter mm	Identification number				Nominal dimensions mm									Maximum stroke length mm	ST			ST...B		
	Ordinary type	Mass (Ref.) g	Heavy load type	Mass (Ref.) g	F_w	D	L_1	L_2	T	t	r	Basic dynamic load rating C N	Basic static load rating C_0 N		Maximum stroke length mm	Basic dynamic load rating C N	Basic static load rating C_0 N			
4	ST 4814	2.9	—	—	4	8	14	9	1.1	0.25	0.3	10	112	59.5	—	—	—			
5	ST 51016	5.6	—	—	5	10	16	10.6	1.1	0.25	0.3	13	121	68.3	—	—	—			
6	ST 61219	8.9	—	—	6	12	19	13.2	1.1	0.25	0.3	15	278	168	—	—	—			
8	ST 81524	15.6	ST 81524 B	16.8	8	15	24	17.1	1.5	0.5	0.5	24	315	211	8	512	422			
10	ST 101930	28.8	ST 101930 B	31.2	10	19	30	22.7	1.5	0.5	0.5	30	659	466	8	1 070	932			
12	ST 122332	42	ST 122332 B	46	12	23	32	24.5	1.5	0.5	0.5	32	1 110	822	8	1 800	1 640			
16	ST 162837	71	ST 162837 B	75	16	28	37	29.1	1.5	0.5	0.5	40	1 230	998	16	1 990	2 000			
20	ST 203245	99	ST 203245 B	106	20	32	45	35.8	2	0.5	0.5	54	1 390	1 250	28	2 250	2 500			
25	ST 253745	117	ST 253745 B	125	25	37	45	35.8	2	0.5	1	54	1 450	1 430	28	2 360	2 850			
30	ST 304565	205	ST 304565 B	220	30	45	65	53.5	2.5	0.5	1	82	3 110	3 160	44	5 060	6 320			
35	ST 355270	329	ST 355270 B	346	35	52	70	58.5	2.5	0.7	1.5	92	3 290	3 550	54	5 340	7 100			
40	ST 406080	516	ST 406080 B	540	40	60	80	68.3	2.5	0.7	1.5	108	4 340	4 810	66	7 050	9 630			
45	ST 456580	563	ST 456580 B	588	45	65	80	68.3	2.5	0.7	1.5	108	4 550	5 330	66	7 390	10 700			
50	ST 5072100	827	ST 5072100 B	862	50	72	100	86.4	3	1	1.5	138	5 790	6 970	88	9 400	13 900			
55	ST 5580100	1 160	ST 5580100 B	1 200	55	80	100	86.4	3	1	2	138	6 030	7 630	88	9 800	15 300			
60	ST 6085100	1 240	ST 6085100 B	1 290	60	85	100	86.4	3	1	2	138	6 260	8 300	88	10 200	16 600			
70	ST 7095100	1 400	ST 7095100 B	1 450	70	95	100	86.4	3	1	2	138	6 510	9 320	88	10 600	18 600			
80	ST 80110100	2 050	ST 80110100 B	2 110	80	110	100	86	3	1.5	2	132	8 230	12 200	76	13 400	24 400			
90	ST 90120100	2 250	ST 90120100 B	2 330	90	120	100	86	3	1.5	2	132	8 550	13 500	76	13 900	27 000			
100	ST 100130100	2 440	ST 100130100 B	2 520	100	130	100	86	3	1.5	2	132	8 820	14 800	76	14 300	29 500			

ST • STSI • BG

IKO Stroke Rotary Bushing **With Seal**

	Ordinary type						Heavy load type					
Shape	ST...UU						ST...UUB					
Size	8	10	12	16	20	25	—	—	—	—	—	—
	30	35	40	45	50	55	30	35	40	45	50	55
	60	70	80	90	100		60	70	80	90	100	

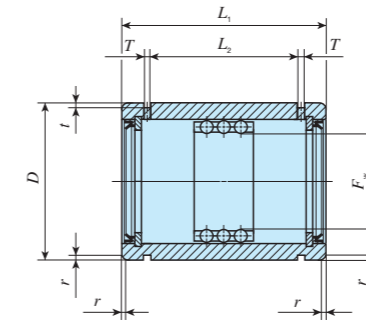

ST...UU

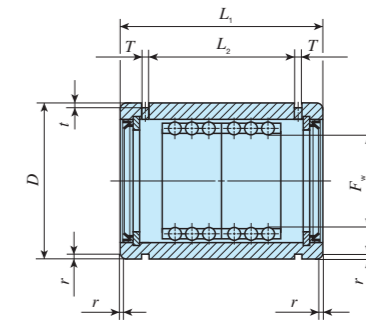

ST...UUB

Shaft diameter mm	Identification number				Nominal dimensions mm									ST...UU			ST...UUB		
	Ordinary type	Mass (Ref.) g	Heavy load type	Mass (Ref.) g	F_w	D	L_1	L_2	T	t	r	Maximum stroke length mm	Basic dynamic load rating C N	Basic static load rating C_0 N	Maximum stroke length mm	Basic dynamic load rating C N	Basic static load rating C_0 N		
8	ST 81524 UU	16.5	—	—	8	15	24	12.3	1.5	0.5	0.5	14	315	211	—	—	—		
10	ST 101930 UU	30.7	—	—	10	19	30	15.5	1.5	0.5	0.5	16	659	466	—	—	—		
12	ST 122332 UU	45	—	—	12	23	32	17.1	1.5	0.5	0.5	17	1 110	822	—	—	—		
16	ST 162837 UU	74	—	—	16	28	37	21.1	1.5	0.5	0.5	24	1 230	998	—	—	—		
20	ST 203245 UU	107	—	—	20	32	45	26.8	2	0.5	0.5	32	1 390	1 250	—	—	—		
25	ST 253745 UU	121	—	—	25	37	45	26.8	2	0.5	1	32	1 450	1 430	—	—	—		
30	ST 304565 UU	215	ST 304565 UU B	230	30	45	65	45.1	2.5	0.5	1	65	3 110	3 160	27	5 060	6 320		
35	ST 355270 UU	342	ST 355270 UU B	359	35	52	70	50.1	2.5	0.7	1.5	75	3 290	3 550	37	5 340	7 100		
40	ST 406080 UU	529	ST 406080 UU B	553	40	60	80	59.9	2.5	0.7	1.5	91	4 340	4 810	49	7 050	9 630		
45	ST 456580 UU	577	ST 456580 UU B	602	45	65	80	59.9	2.5	0.7	1.5	91	4 550	5 330	49	7 390	10 700		
50	ST 5072100 UU	836	ST 5072100 UU B	871	50	72	100	77.4	3	1	1.5	120	5 790	6 970	70	9 400	13 900		
55	ST 5580100 UU	1 190	ST 5580100 UU B	1 230	55	80	100	77.4	3	1	2	120	6 030	7 630	70	9 800	15 300		
60	ST 6085100 UU	1 270	ST 6085100 UU B	1 320	60	85	100	77.4	3	1	2	120	6 260	8 300	70	10 200	16 600		
70	ST 7095100 UU	1 430	ST 7095100 UU B	1 480	70	95	100	77.4	3	1	2	120	6 510	9 320	70	10 600	18 600		
80	ST 80110100 UU	2 080	ST 80110100 UU B	2 140	80	110	100	77	3	1.5	2	114	8 230	12 200	58	13 400	24 400		
90	ST 90120100 UU	2 290	ST 90120100 UU B	2 370	90	120	100	77	3	1.5	2	114	8 550	13 500	58	13 900	27 000		
100	ST 100130100 UU	2 540	ST 100130100 UU B	2 620	100	130	100	77	3	1.5	2	114	8 820	14 800	58	14 300	29 500		

ST • STSI • BG

Miniature Stroke Rotary Bushing

STSI



Points

1 Rotational and linear motions

With the combination of an external cylinder with cylindrical raceway and balls incorporated in the retainer, rotary and linear motion in the axial direction is possible simultaneously with rotational motion.

2 Super small size

With the ultra-small sized balls incorporated in a thin external cylinder, small diameter and small sectional height are realized.

3 Super precision

Balls of high accuracy are incorporated with super-finished external cylinder and shaft to be adjusted to zero or minimal amount of preload, which realizes rotational motion and rotary and linear motion of high accuracy.

4 Extremely smooth operation

Since each component is precisely grounded and adjusted to ideal preload condition, extremely smooth and stable operation with small frictional resistance for long term can be achieved.

Identification Number and Specification

Example of an identification number

The specification of STSI series is indicated by the identification number. Indicate the identification number, consisting of a model code, dimensions, length, and a selection code for each specification to apply.

	1	2	3	4	5	6	7	1	8
Assembled set With a shaft	STSI	4			20 - 15 - 50				
Without a shaft	STS	4			20 - 15				/M1
Part External cylinder	OR		6	8	20			A	/M1
Ball cage	BK	4	6			15		A	
Shaft	SF	4					50	A	/M1

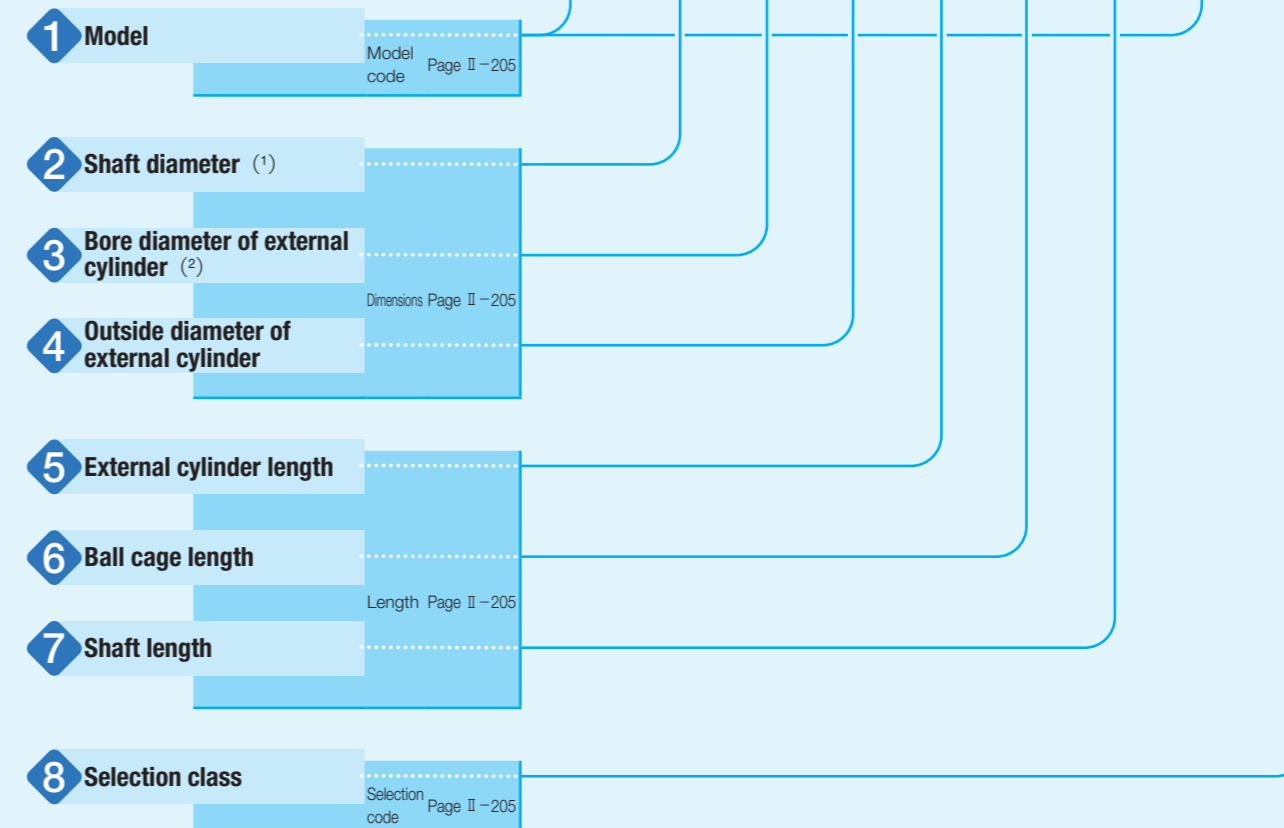

Notes (1) Indicates inscribed circle diameter for assembled set without a shaft or ball cage.
(2) Indicates circumscribed circle diameter for ball cage.

Identification Number and Specification

1 Model	Miniature Stroke Rotary Bushing (STSI series)	Assembled set with a shaft : STSI Assembled set without a shaft : STS External cylinder : OR...A Ball cage : BK...A Shaft : SF...A
2 Shaft diameter		Indicate the shaft diameter in mm. Indicates inscribed circle diameter for assembled set without a shaft or ball cage.
3 Bore diameter of external cylinder		Indicate the bore diameter of external cylinder in mm. Indicates circumscribed circle diameter for ball cage.
4 Outside diameter of external cylinder		Indicate the outside diameter of external cylinder in mm.
5 External cylinder length		Indicate the external cylinder length in mm.
6 Ball cage length		Indicate the ball cage length in mm.
7 Shaft length		Indicate the shaft length in mm.
8 Selection class	M1 class : M1 M2 class : M2 M3 class : M3	Selection code and tolerances are shown in Table 3. For combination of each part, assemble parts with the same selection code.

Table 1 Models of STSI series

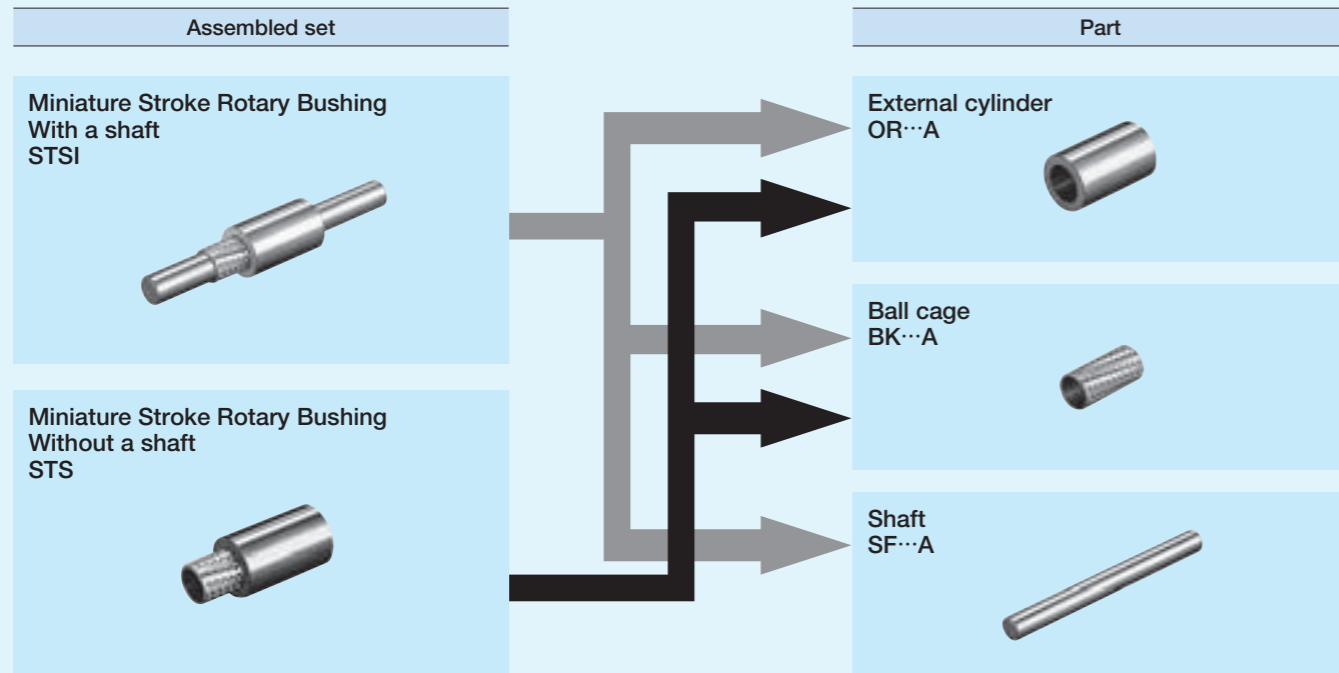

Accuracy

Table 2 Tolerance and allowance

Nominal dimensions of outside diameter of external cylinder mm		Tolerance of outside diameter of external cylinder μm		Radial runout of outside diameter of external cylinder μm	Tolerance of length of external cylinder and shaft mm
Over	Incl.	High	Low		
3	6	0	-5	8	± 0.1
6	10	0	-6		
10	18	0	-8		
18	30	0	-9	9	

Table 3 Selection code and tolerance

unit: μm

Selection code	Tolerance of bore diameter of external cylinder		Tolerance of inscribed circle diameter		Tolerance of shaft diameter	
	High	Low	High	Low	High	Low
M1	-1	-3	-1	-3	0	-1
M2	-2	-4	-2	-4	-1	-2
M3	-3	-5	-3	-5	-2	-3

Load Rating

Load rating of the STSI series represents the value obtained when load is evenly distributed without the ball incorporated in the ball cage being dropped from the external cylinder and shaft end.

Lubrication

Grease is not pre-packed in the STSI series, so please perform adequate lubrication as needed. Both of oil lubrication and grease lubrication are available in the STSI series. For grease lubrication, it is typically applied lightly to the shaft and raceway of the external cylinder. Use of high-quality lithium-soap base grease is recommended for the grease to use.

Precaution for Use

1 Fitting

The STSI series is assembled to slight preload state to obtain high motion accuracy. Use external cylinder and housing hole of the STSI series with clearance fit to avoid any effect of press-fitting on inscribed circle diameter. In addition, for combination of an external cylinder, a ball cage and a shaft, select an external cylinder and a shaft with the same selection code to be combined with a ball cage.

2 Operating temperature

The maximum operating temperature is 120°C and temperature up to 100°C is allowed for continuous operation. When the temperature exceeds 100°C, contact **IKO**.

3 Mounting

Typically, to fix the external cylinder and housing hole, the external cylinder end is fixed to the axial direction with stop ring or adhesive agent is used.

The ball cage is mounted through the shaft after the external cylinder is fixed to the housing hole. At this point, mounting becomes easier if the ball cage is shifted by one half of assembly insertion amount of the shaft in insert direction of the shaft so that the ball cage is positioned at the regular position after mounting.

4 Insertion of shaft

When inserting a shaft into an external cylinder, be careful not to pry open or give shock to the shaft.

IKO Miniature Stroke Rotary Bushing

	Assembled set with a shaft				Assembled set without a shaft				External cylinder				Ball cage				Shaft			
Shape	STSI				STS				OR...A				BK...A				SF...A			
Size	2	3	4	5	2	3	4	5	2	3	4	5	2	3	4	5	2	3	4	5
	6	8	10	12	6	8	10	12	6	8	10	12	6	8	10	12	6	8	10	12

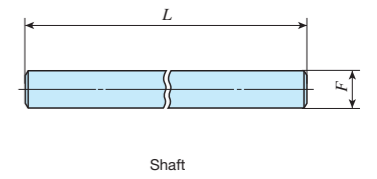
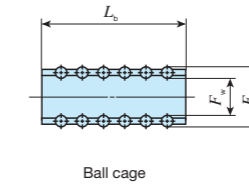
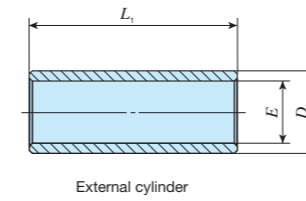

Shaft diameter mm	Identification number of assembled set without a shaft	External cylinder					Ball cage					Basic static load rating ⁽¹⁾ C ₀ N	Shaft			Identification number of assembled set with a shaft					
		Identification number	Mass (Ref.) g	Nominal dimensions mm			Identification number	Mass (Ref.) g	F _w	Nominal dimensions mm			Identification number	Mass (Ref.) g	Nominal dimensions mm						
				E	D	L ₁					E _w	L _b				F	L				
2	STS 2 L ₁ -L _b	OR 3 5 10 A	0.9	3.2	5	10	BK 2 3 5 A	0.1	2		3.2	5	10.5	SF 2 20 A	0.5	2	20	STSI 2 L ₁ -L _b -L			
		OR 3 5 15 A	1.3				BK 2 3 10 A	0.3						SF 2 30 A	0.7				30		
3	STS 3 L ₁ -L _b	OR 5 7 10 A	1.5	5	7	10	BK 3 5 10 A	0.7	3		5	10	38.4	SF 3 50 A	2.8	3	50	STSI 3 L ₁ -L _b -L			
		OR 5 7 20 A	2.9				BK 3 5 15 A	1.1						15	57.7				SF 3 60 A	3.3	60
		OR 5 7 30 A	4.4				BK 3 5 20 A	1.4						20	76.9						
4	STS 4 L ₁ -L _b	OR 6 8 10 A	1.7	6	8	10	BK 4 6 10 A	0.9	4		6	10	59.5	SF 4 50 A	4.9	4	50	STSI 4 L ₁ -L _b -L			
		OR 6 8 20 A	3.4				BK 4 6 15 A	1.3						15	89.3				SF 4 60 A	5.9	60
		OR 6 8 30 A	5.2				BK 4 6 20 A	1.8						20	119						
5	STS 5 L ₁ -L _b	OR 7 10 10 A	3.1	7	10	10	BK 5 7 10 A	1.0	5		7	10	81	SF 5 50 A	7.7	5	50	STSI 5 L ₁ -L _b -L			
		OR 7 10 20 A	6.3				BK 5 7 15 A	1.6						15	121				SF 5 80 A	12.3	80
		OR 7 10 30 A	9.4				BK 5 7 20 A	2.0						20	162						
6	STS 6 L ₁ -L _b	OR 8 11 20 A	7.0	8	11	20	BK 6 8 10 A	1.2	6		8	10	103	SF 6 50 A	11.1	6	50	STSI 6 L ₁ -L _b -L			
		OR 8 11 30 A	10.5				BK 6 8 15 A	1.8						15	154				SF 6 80 A	17.7	80
		OR 8 11 40 A	14.1				BK 6 8 20 A	2.3						20	206						
8	STS 8 L ₁ -L _b	OR 10 13 20 A	8.5	10	13	20	BK 8 10 10 A	1.6	8		10	10	105	SF 8 50 A	19.7	8	50	STSI 8 L ₁ -L _b -L			
		OR 10 13 30 A	12.7				BK 8 10 15 A	2.4						15	157				SF 8 80 A	31.5	80
		OR 10 13 40 A	17.0				BK 8 10 20 A	3.2						20	209				SF 8 90 A	35.5	90
10	STS 10 L ₁ -L _b	OR 12 18 20 A	22.2	12	18	20	BK 10 12 15 A	2.8	10		12	15	191	SF 10 80 A	49.3	10	80	STSI 10 L ₁ -L _b -L			
		OR 12 18 30 A	33.3				BK 10 12 20 A	3.8						20	254				SF 10 100 A	61.6	100
		OR 12 18 43 A	47.7				BK 10 12 25 A	4.8						25	318				SF 10 120 A	74.0	120
12	STS 12 L ₁ -L _b	OR 14 20 25 A	31.4	14	20	25	BK 12 14 20 A	4.3	12		14	20	341	SF 12 80 A	71.0	12	80	STSI 12 L ₁ -L _b -L			
		OR 14 20 30 A	37.7				BK 12 14 25 A	5.4						25	427				SF 12 100 A	88.8	100
		OR 14 20 35 A	44.0				BK 12 14 30 A	6.1						30	512						
		OR 14 20 40 A	50.3																		

Note ⁽¹⁾ Represents the value when load is evenly distributed without the ball incorporated in the ball cage being dropped from the external cylinder end.

Remark: L₁, L_b, and L in the identification number field of assembled set without a shaft and assembled set with a shaft represent length of the external cylinder, length of the ball cage, and length of the shaft in the dimension table.

ST • STSI • BG

Stroke Rotary Cage

BG

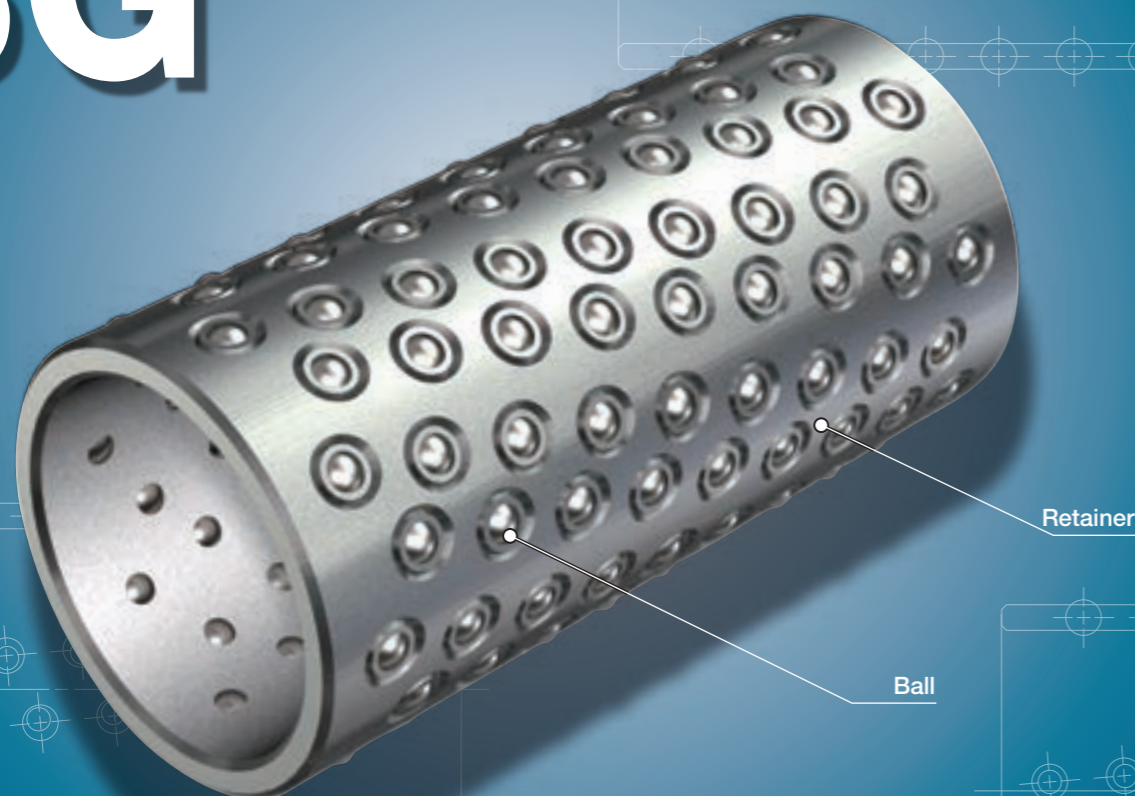

Points

● Rotational and linear motions

High-accuracy balls incorporated into the retainer make use of the raceway accuracy to allow high-accuracy rotational motion and rotary and linear motion.

● Superior high speed operation

As the retainers have high rigidity and light in weight with low inertia, this series is suitable for abrupt operations such as high-speed rotary and linear motion in axial direction.

● Large load rating and high rigidity

In the retainer, balls are incorporated as many as possible. So the load ratings are large and the rigidity is high with small elastic deformation even under fluctuating load or offset load.

● Long life

Each ball held in the retainer is arranged in a spiral formation in order to prevent the balls from tracing the same path. Rolling contact fatigue of the shaft and housing raceways is thereby minimized, and stable high accuracy can be assured for long periods of time.

Identification Number and Specification

Example of an identification number

The specification of BG series is indicated by the identification number. Indicate the identification number, consisting of a model code and dimensions.

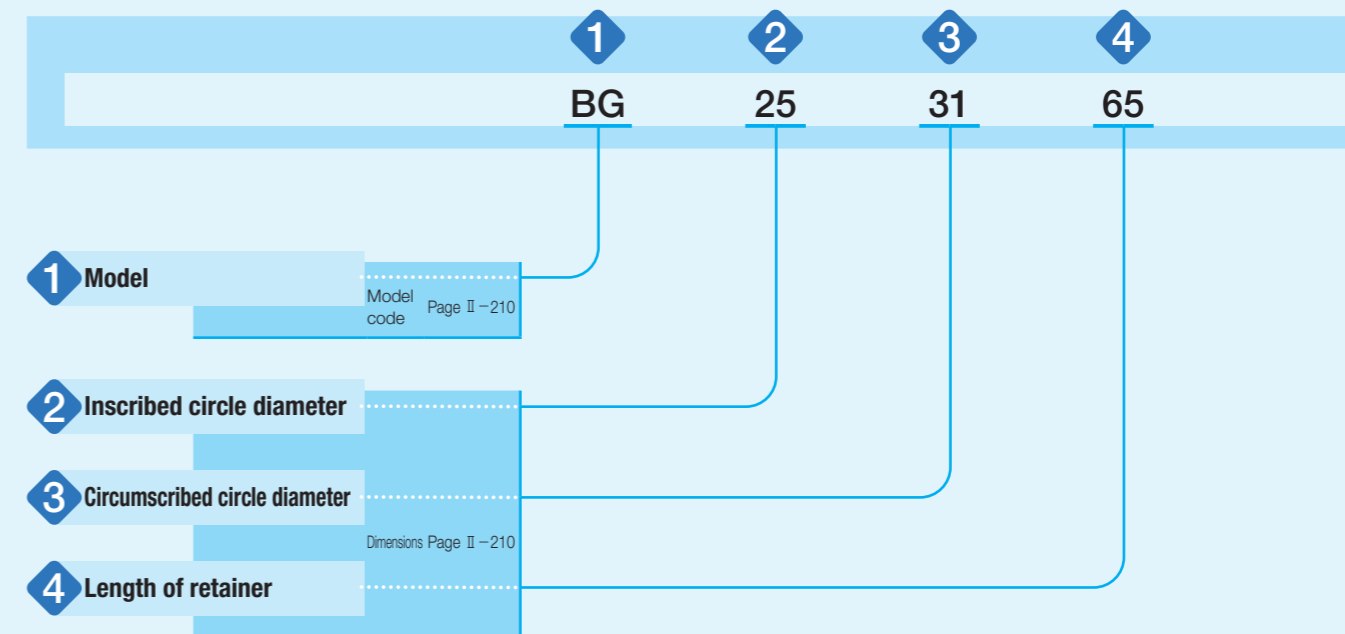

Identification Number and Specification

1	Model	Stroke Rotary Cage (BG series)	: BG
2	Inscribed circle diameter		Indicate the inscribed circle diameter in mm.
3	Circumscribed circle diameter		Indicate the circumscribed circle diameter in mm.
4	Length of retainer		Indicate the length of retainer in mm.

Allowance of Velocity

The BG series is capable of rotation and rotary and linear motion. However, allowance of velocity for these motions performed at the same time is obtained from the equation (1). Typical values are indicated in Table 1.

$$DN \geq D_{pw} n + 10 S n_1 \dots \dots \dots (1)$$

where, DN : Allowance of velocity (see Table 1)
 n : Rotational speed, rpm
 n_1 : Number of strokes per minute, cpm
 S : Stroke length, mm
 D_{pw} : Pitch circle diameter of balls, mm
 $(D_{pw} = \frac{F_w + E_w}{2})$
 F_w : Inscribed circle diameter, mm
 E_w : Circumscribed circle diameter, mm

However, applicable when $n_1 \leq 5000, S n_1 \leq 50000$.

Table 1 Allowance of velocity

Lubrication conditions	DN
Oil lubrication	600 000
Grease lubrication	300 000

Precaution for Use

① Fitting

BG series is generally used with a slight radial internal clearance fit. Recommended fits are shown in Table 2. When it is used for a guide post of the press die set or high operation accuracy is required, a preload is generally given. The tolerances of dimensions of the shaft and housing bore in this case are shown in Table 3. However, since excessive preload shortens the life of Stroke Rotary Cage, it is suggested that the lower limit of radial clearance is not smaller than the value shown in Table 4.

Table 2 General fit

Tolerance class	
Shaft	Housing hole
h5, h6	H6, H7

Table 3 Tolerances of dimensions for shaft and housing hole
unit: μm

Shaft		Housing hole			
Nominal dimensions mm	h5		Nominal dimensions mm	K5	
	H	L		H	L
19	0	-9	25	+1	-8
22	0	-9	28	+1	-8
25	0	-9	31	+2	-9
28	0	-9	36	+2	-9
32	0	-11	40	+2	-9
38	0	-11	48	+2	-9

Table 4 Lower limit of radial internal clearance unit: μm

Nominal dimensions of shaft mm	Lower limit of radial internal clearance
19	-5
22	-5
25	-5
28	-7
32	-7
38	-7

② Raceway

BG series is used with a shaft and housing hole as raceway surfaces. Recommended values for surface hardness and roughness of mating raceway are shown in Table 5 and the recommended values for the minimum effective hardening depth are shown in Table 6. When some of the balls held in the retainer escape the housing raceway and operate in linear motion, it is recommended that the housing raceway ends should be slightly chamfered so that the balls enter or exit smoothly.

Table 5 Surface hardness and roughness of raceway

Item	Recommended value	Remark
Surface hardness	58~64HRC	When the surface hardness is low, multiply the load rating by hardness factor ⁽¹⁾ .
Surface roughness	0.2 μmRa or lower (0.8 μmRy or lower)	Where accuracy standard is low, around 0.8 μmRa (3.2 μmRy) is also allowed.

Note ⁽¹⁾ For hardness factor, refer to Fig. 3 in page III-5.

Table 6 Minimum effective hardening depth of raceway
unit: mm

Nominal dimensions of shaft and housing hole		Recommended value for minimum effective hardening depth
Over	Incl.	
-	28	0.8
28	50	1.0

IKO Stroke Rotary Cage

Shape	BG		
			
Size	19	22	25
	28	32	38

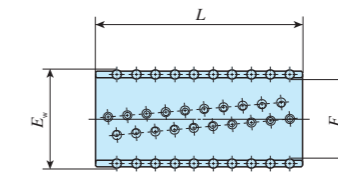

Shaft diameter mm	Identification number	Mass (Ref.) g	Nominal dimensions mm			Basic dynamic load rating ⁽¹⁾ C N	Basic static load rating ⁽¹⁾ C ₀ N
			F _w	E _w	L		
19	BG 192555*	33	19	25	55	2 330	2 600
22	BG 222860*	40	22	28	60	2 490	2 950
25	BG 253165*	48	25	31	65	2 660	3 390
28	BG 283670*	76	28	36	70	3 830	4 660
32	BG 324075*	93	32	40	75	4 480	6 030
38	BG 384880*	162	38	48	80	6 750	9 390

Note ⁽¹⁾ Basic dynamic load rating and basic static load rating are values when balls incorporated into the retainer share the load evenly without escaping the raceway.

Remark: The identification numbers with * are our semi-standard items.

Roller Way & Flat Roller Cage

Roller Way
Flat Roller Cage



Roller Way

RW

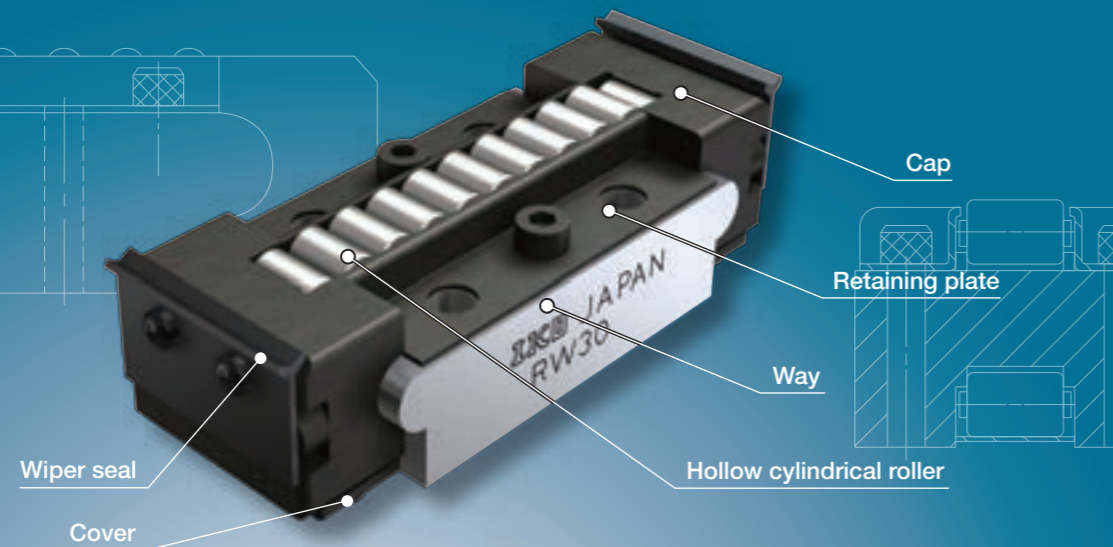

SR

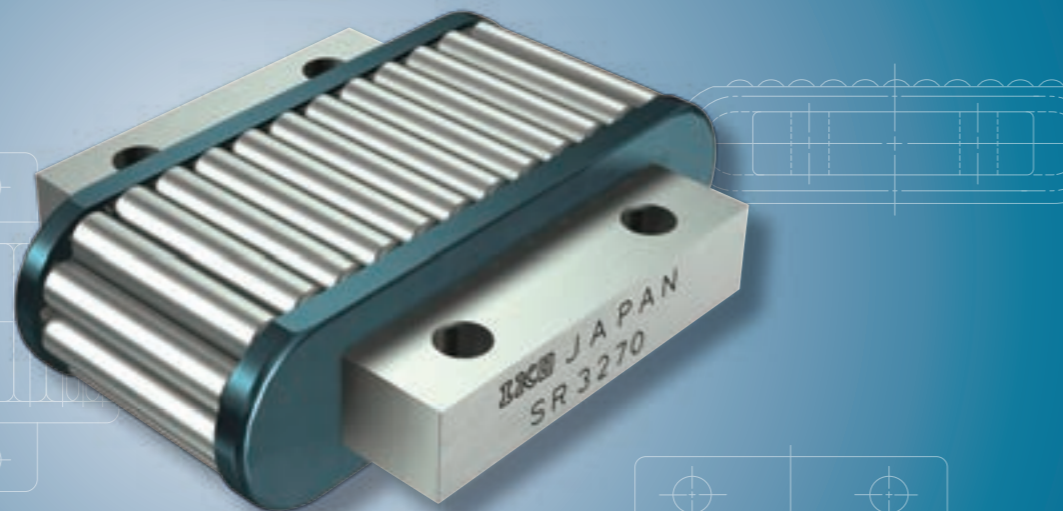

GSN

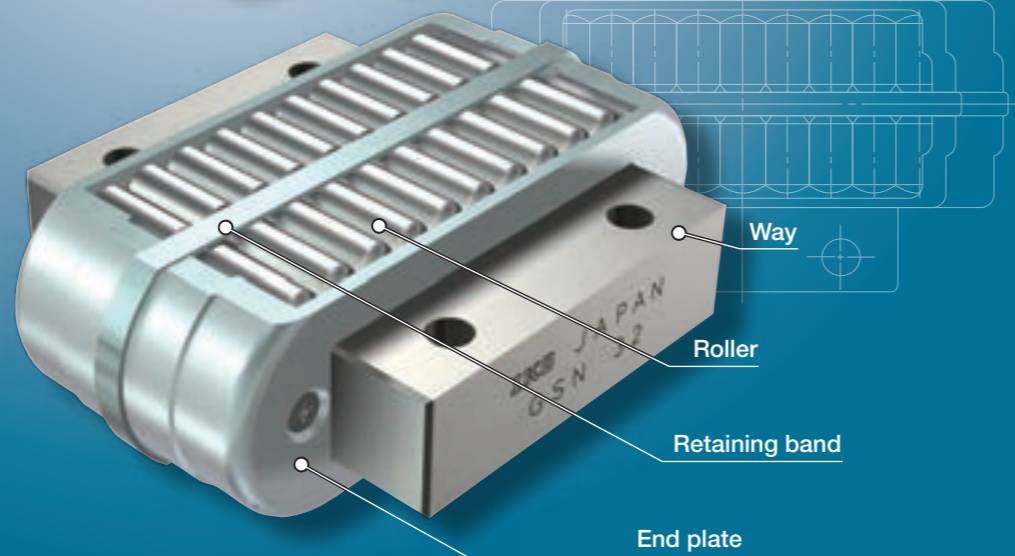

Points

1 High rigidity and accuracy

Since the high accuracy roller is built into the highly flat surface way finished by accurate ground, the product has a high rigidity and high accuracy. Also because the variation of operation height can be selected in the unit of 2 μm, the load can be evenly distributed even in the multiple-use environment.

2 Smooth motion

The structure of all models lets the roller to be guided accurately without creating skew, yielding an extremely stable and smooth linear motion.

Identification Number and Specification

Example of an identification number

The specifications of RW, SR and GSN are indicated by the identification number. Indicate the identification number, consisting of a model code, dimensions, a part code, a classification symbol, and a selection code for each specification to apply.

	1	2	3	4	5
	RW	40	UU	SP	B4
	SR	2050		SP	B4
	GSN	20		SP	B4

1 Model Model code Page II - 216

2 Size Dimensions Page II - 216

3 Wiper seal Part code Page II - 217

4 Accuracy class Classification symbol Page II - 217

5 Selection class Selection code Page II - 217

Identification Number and Specification -Model · Size-

1 Model	Roller Way RW : RW Roller Way RW inch series : RWB Roller Way SR : SR Roller Way GSN : GSN
For applicable models and sizes, see Table 1.1 and Table 1.2.	

2 Size	Indicate the representative width in mm. For the inch series, indicate the width in the unit of 1/16 inch. For applicable models and sizes, see Table 1.1 and Table 1.2.
--------	--

RW · SR · GSN
FT · FTW...A

Table 1.1 Models and sizes of RW, SR and GSN (Metric series)



Shape	Model	Size									
		15	20	25	26	30	32	40	50	70	95
	RW	-	-	-	○	○	-	○	○	○	○
	SR	○	○	○	-	-	○	○	○	-	-
	GSN	○	○	○	-	-	○	○	○	-	-

Table 1.2 Models and sizes of RWB (Inch series)

Shape	Model	Size					
		14	16	24	32	48	64
	RWB	○	○	○	○	○	○

3 Wiper seal

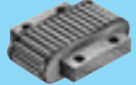
Without wiper seal	: No symbol	Applicable to Roller Way RW.
With wiper seal	: UU	Attach the wiper seal in the linear motion direction. This wiper seal is made of special synthetic rubber in double-lipped shape and has high removal performance against foreign substances.

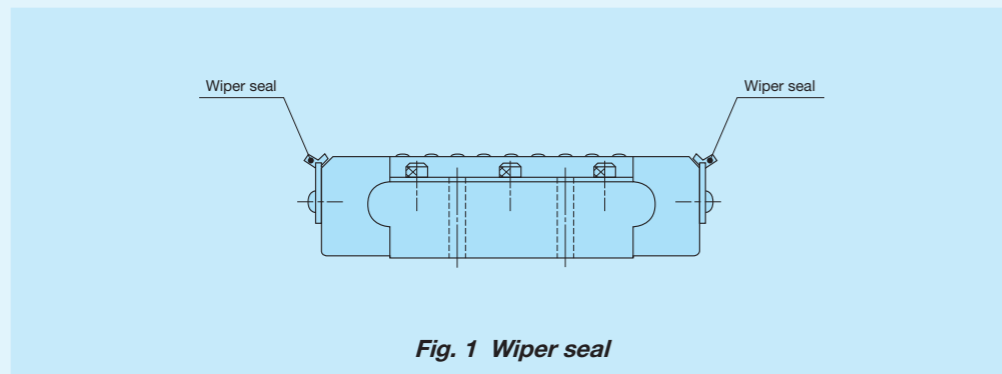

4 Accuracy class

Ordinary	: No symbol	For applicable accuracy class, see Table 2.1 and Table 2.2.
High	: H	
Precision	: P	For details of accuracy class, see Table 3.1, Table 3.2, and Table 4.
Super precision	: SP	

5 Selection class

When many are used on the same surface, it is required to use those with the same selection code from tolerances of dimensions in H of Table 4 to evenly distribute the load. When tolerances of dimensions of H is not specified, please specify a classification symbol only.

Table 2.1 Application of accuracy class of RW, SR and GSN (Metric series)

Size	Class (classification symbol)			
	Ordinary ⁽¹⁾ (No symbol)	High (H)	Precision (P)	Super precision (SP)
15	○	○	○	○
20	○	○	○	○
25	○	○	○	○
26	-	○	○	○
30	-	○	○	○
32	○	○	○	○
40	○	○	○	○
50	○	○	○	○ ⁽²⁾
70	-	○	○	-
95	-	○	○	-

Notes ⁽¹⁾ Applicable to SR and GSN.
⁽²⁾ Applicable to RW.

Table 2.2 Application of accuracy class of RWB (Inch series)

Size	Class (classification symbol)			
	Ordinary (No symbol)	High (H)	Precision (P)	Super precision (SP)
14	-	○	○	○
20	-	○	○	○
24	-	○	○	○
32	-	○	○	○
48	-	○	○	-
64	-	○	○	-

Table 3.1 Tolerances of RW and RWB width W

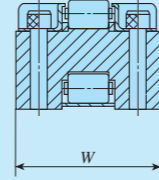

Size	RW		Size	RWB	
	Dim. W	tolerance mm		Dim. W	tolerance inch
26	0		14	0	
30	-0.05		16	-0.002	
40			24		
50	0		32	0	
70	-0.07		48	-0.003	
95	0		64	0	
	-0.10			-0.004	

Table 3.2 Tolerances of SR and GSN width W₁, and length L₁

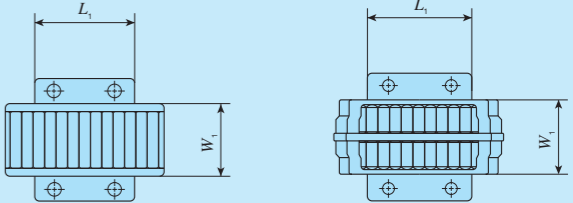

Size	Dim. tolerance, unit: mm	
	Dim. W tolerance, ₁	Dim. L tolerance, ₁
15		
20	0	0
25	-0.2	-0.2
32		
40		
50	0	0
	-0.3	-0.3

Table 4 Selection code, and tolerance of height H and operation height A

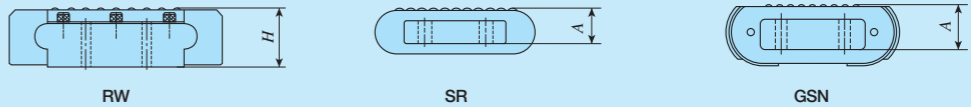

Item	Selection code	Dim. tolerance of height H and operation height A	
		Metric series mm	Inch series inch
Accuracy class			
Ordinary (no symbol)	-	0 ~ -0.010	-
High (H)	E 5	0 ~ -0.005	0 ~ -0.0002
	E 10	-0.005 ~ -0.010	-0.0002 ~ -0.0004
Precision (P)	C 3	0 ~ -0.003	0 ~ -0.00012
	C 6	-0.003 ~ -0.006	-0.00012 ~ -0.00024
	C 9	-0.006 ~ -0.009	-0.00024 ~ -0.00036
Super precision (SP)	B 2	0 ~ -0.002	0 ~ -0.00008
	B 4	-0.002 ~ -0.004	-0.00008 ~ -0.00016
	B 6	-0.004 ~ -0.006	-0.00016 ~ -0.00024
	B 8	-0.006 ~ -0.008	-0.00024 ~ -0.00032
	B 10	-0.008 ~ -0.010	-0.00032 ~ -0.00040

Precaution for Use

1 Raceway

Recommended values for surface hardness and roughness of mating raceway are shown in Table 5 and the recommended value for the minimum effective hardening depth is shown in Table 6.1 and Table 6.2.

Table 5 Surface hardness and roughness of raceway

Item	Recommended value	Remark
Surface hardness	58~64HRC	When the surface hardness is low, multiply the load rating by hardness factor (1).
Surface roughness	0.2 μmRa or lower (0.8 μmRy or lower)	Where accuracy standard is low, around 0.8 μmRa (3.2 μmRy) is also allowed.

Note (1) For hardness factor, refer to Fig. 3 in page III-5.

Table 6.1 Minimum effective hardening depth of raceway (RW and RWB) unit: mm

Identification number	Recommended value for minimum effective hardening depth
RW 26 RWB 14	0.8
RW 30 RWB 16	1.0
RW 40 RWB 24	1.5
RW 50 RWB 32	2.0
RW 70 RWB 48	2.5
RW 95 RWB 64	3.0

Table 6.2 Minimum effective hardening depth of raceway (SR and GSN) unit: mm

Identification number	Recommended value for minimum effective hardening depth
SR 15 GSN 15	0.8
SR 20 GSN 20	1.0
SR 25 GSN 25	1.0
SR 32 GSN 32	1.5
SR 40 GSN 40	1.5
SR 50 GSN 50	2.0

2 Accuracy of mounting surface

For accuracy of mounting surface, values in Table 7.1 and Table 7.2 are recommended.

Table 7.1 Accuracy of mounting surface (RW and RWB)

Item	Recommended value
	0.02/100 or lower
	0.015/100 or lower
	0.05/100 or lower

Table 7.2 Accuracy of mounting surface (SR and GSN)

Item	Recommended value
	0.02/100 or lower
	0.015/100 or lower
	0.05/100 or lower

3 Groove machining on SR and GSN mounting surface

When mounting SR and GSN to the groove-machined mounting surface, the groove depth E should be deeper than the height from the bottom surface of the way to the bottom of the SR and GSN to provide clearance for oil pool. (See Fig. 2.)

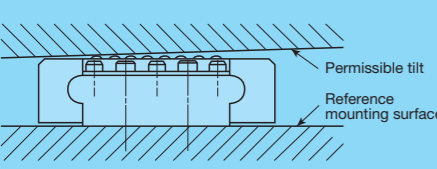
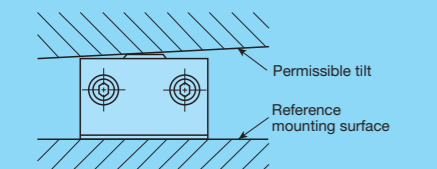
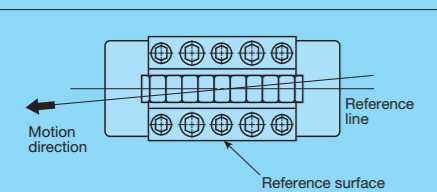
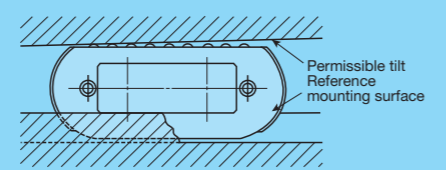
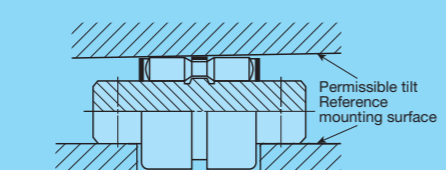
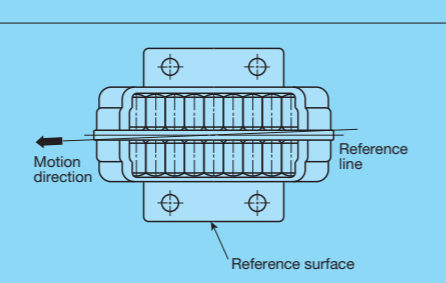
Other than the above, groove width W corresponding to the width W_1 for SR should be as wide as clearance fit and the relation between the clearance and the groove position on the reference surface side must be considered.

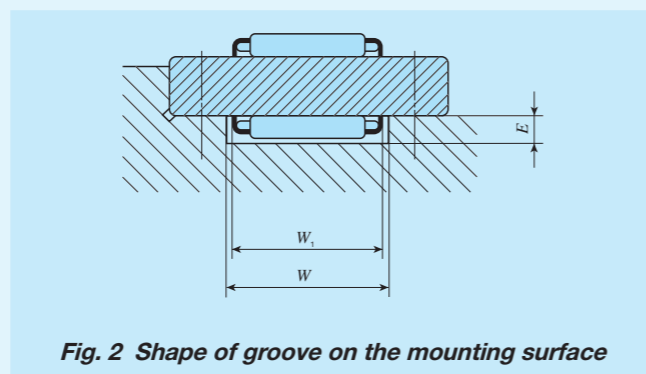

4 Operating temperature

The maximum operating temperature is 120°C and temperature up to 100°C is allowed for continuous operation. When the temperature exceeds 100°C, contact **IKO**.

Precaution for Mounting

1 Reference mounting surface

To mount RW, RWB, SR, and GSN in the linear motion direction, mount them by referring the opposite side of the **IKO** mark on the way end as reference surface. (See Fig. 3.) In addition, the surface under load is the upside of the **IKO** mark on the way end seen as the normal position.

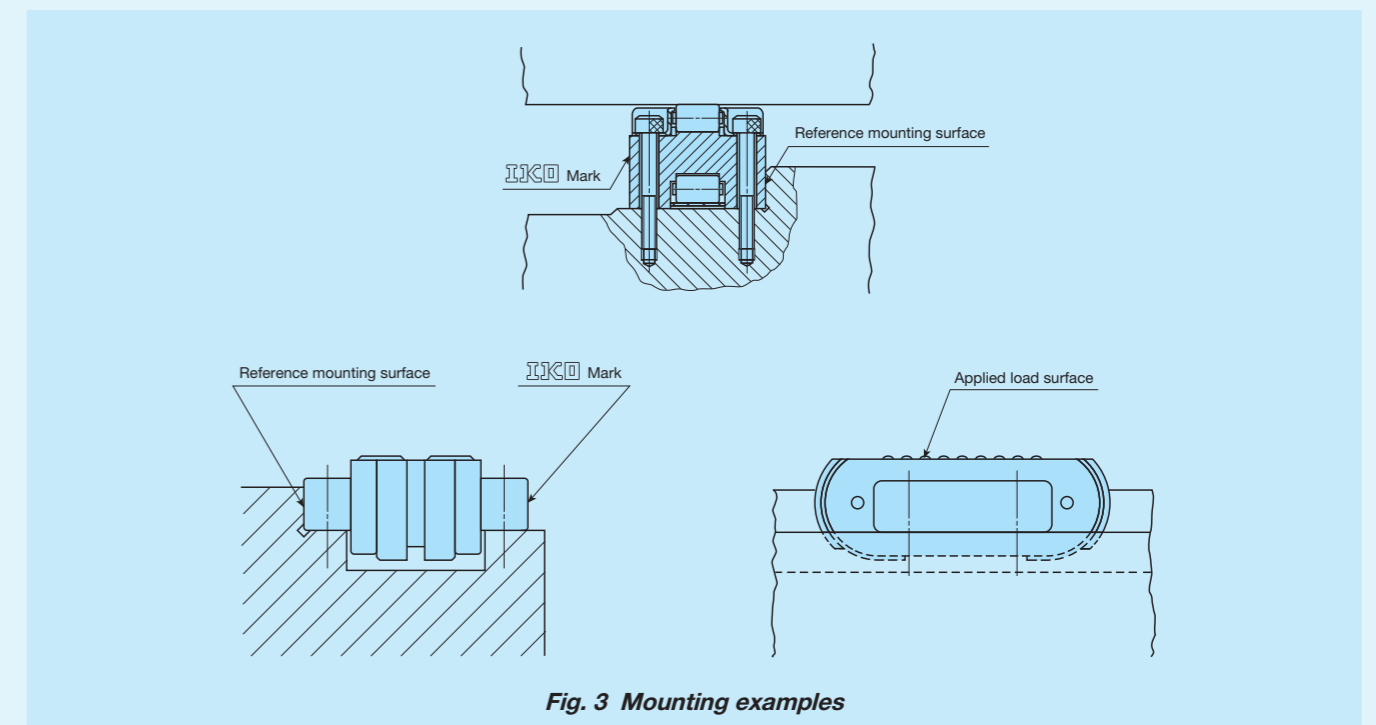

2 How to mount SR and GSN

To mount it, fix the way directly to a table or a bed with bolts, or fix it with pressure plate as indicated in Fig. 4. For SR, mounting with pressure plate is recommended.

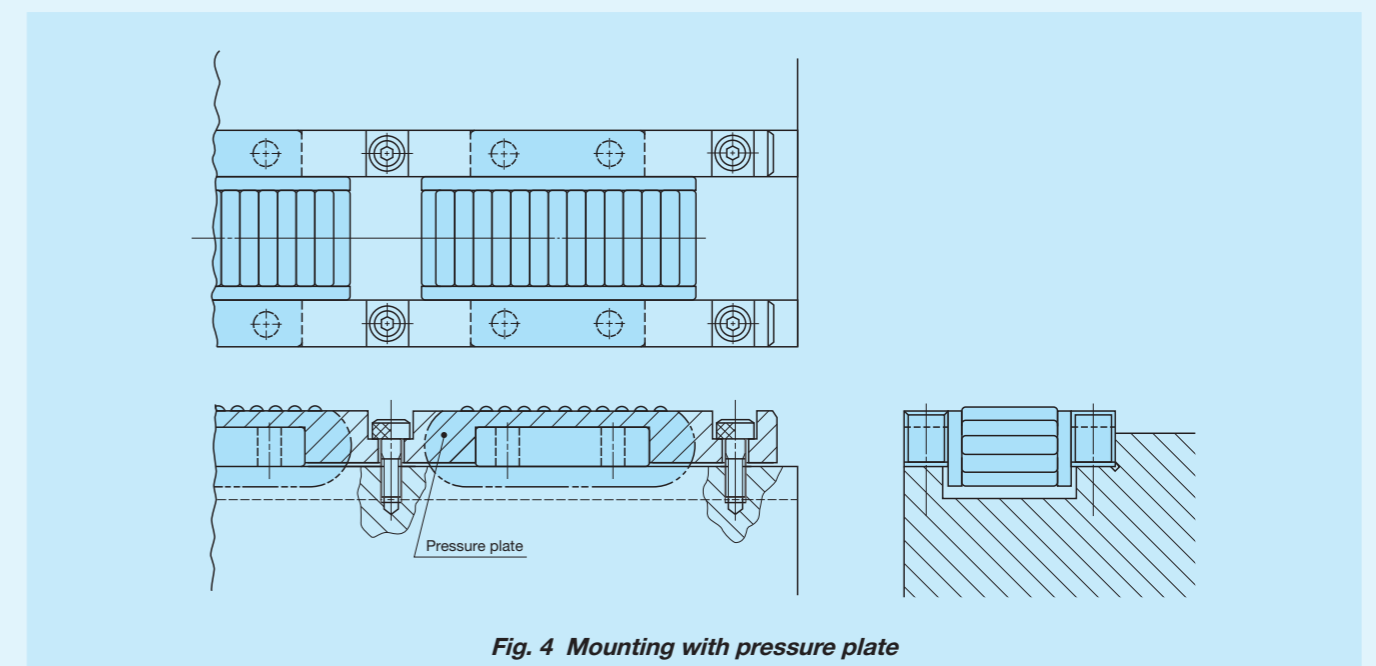

IKO Roller Way

Shape	RW		
			
Size	26	30	40
	50	70	95

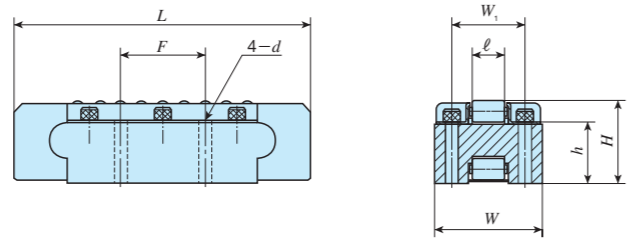

Identification number	Mass (Ref.) g	Nominal dimensions mm								Basic dynamic load rating C N	Basic static load rating C ₀ N
		W	H	L	ℓ	F	W ₁	h	d		
RW 26	74	26	14	50	6	19	16	10	3.4	25 000	40 100
RW 30	179	30	19	70	7.5	25.4	19	14	4.5	39 800	71 200
RW 40	740	40	28	100	11.3	38.1	26	21	5.5	85 700	160 000
RW 50	1 750	50	38	140	15	50.8	35	28.5	6.6	154 000	314 000
RW 70	5 260	70	57	200	22.5	76.2	48	42.5	9.0	306 000	638 000
RW 95	12 700	95	76	270	30	101.6	65	56.5	11.0	514 000	1 130 000

IKO Roller Way Inch Series

Shape	RWB		
			
Size	14	16	24
	32	48	64

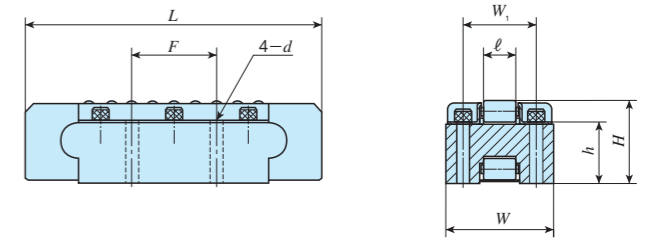

Identification number	Mass (Ref.) g	Nominal dimensions inch / mm								Basic dynamic load rating C N	Basic static load rating C ₀ N
		W	H	L	ℓ	F	W ₁	h	d		
RWB 14*	91	7/8 22.225	9/16 14.288	1.97 50	0.236 6	3/4 19.050	43/64 17.066	0.41 10.4	0.125 3.2	25 000	40 100
RWB 16*	227	1 25.400	3/4 19.050	2.76 70	0.295 7.5	1 25.400	13/16 20.638	0.56 14.2	0.125 3.2	39 800	71 200
RWB 24*	730	1 1/2 38.100	1 1/8 28.575	3.94 100	0.445 11.3	1 1/2 38.100	1 7/32 30.956	0.85 21.5	0.180 4.6	85 700	160 000
RWB 32*	1 770	2 50.800	1 1/2 38.100	5.51 140	0.591 15	2 50.800	1 5/8 41.275	1.12 28.5	0.206 5.2	154 000	314 000
RWB 48*	5 670	3 76.200	2 1/4 57.150	7.88 200	0.886 22.5	3 76.200	2 7/16 61.912	1.68 42.8	0.266 6.8	306 000	638 000
RWB 64*	13 500	4 101.600	3 76.200	10.63 270	1.181 30	4 101.600	3 1/4 82.550	2.24 57.0	0.328 8.3	514 000	1 130 000

Remark: The identification numbers with * are our semi-standard items.

Shape	SR		
			
Size	15	20	25
	32	40	50

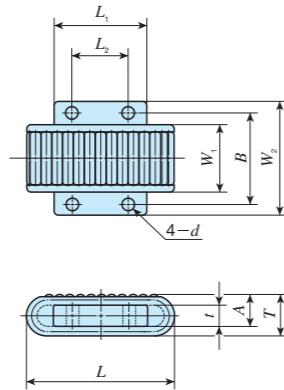

Shape	GSN		
			
Size	15	20	25
	32	40	50

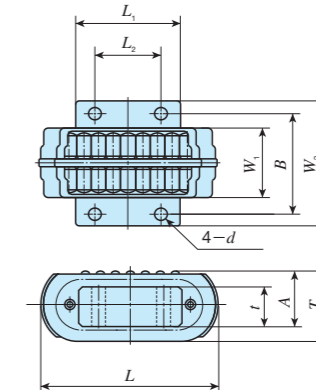

Identification number	Mass (Ref.) g	Nominal dimensions mm											Basic dynamic load rating C N	Basic static load rating C ₀ N
		W ₁	W ₂	L	A	T	L ₁	L ₂	B	d	t			
SR 1540	62	15	30	40	11	15	20	12	23	3.3	7	26 500	45 900	
— GSN 15	82	15	30	40	15	20	19	12	23	3.4	11	22 300	36 000	
SR 2050	120	20	36	50	12	16	30	18	29	3.8	8	42 800	96 300	
— GSN 20	145	20	36	50	15	20	29	18	29	3.4	11	40 100	87 900	
SR 2560	210	25	45	60	14	19	35	20	36	4.8	9	67 300	156 000	
— GSN 25	260	25	45	60	18	24.5	35	20	36	4.5	13	58 900	131 000	
SR 3270	345	32	55	70	15	20	45	27	44	5.5	10	97 500	271 000	
— GSN 32	413	32	55	70	18	24.5	45	27	44	4.5	13	88 800	241 000	
SR 4090	750	40	68	87	21	28	55	35	54	6.5	14	143 000	373 000	
— GSN 40	940	40	68	92	25	34	54	35	54	5.5	18	133 000	337 000	
SR 50125	1 870	50	82	125	30	40	78	50	66	8.5	20	252 000	673 000	
— GSN 50	1 800	50	82	121	30	42	77	50	66	6.6	20	242 000	634 000	

Flat Roller Cage

FT

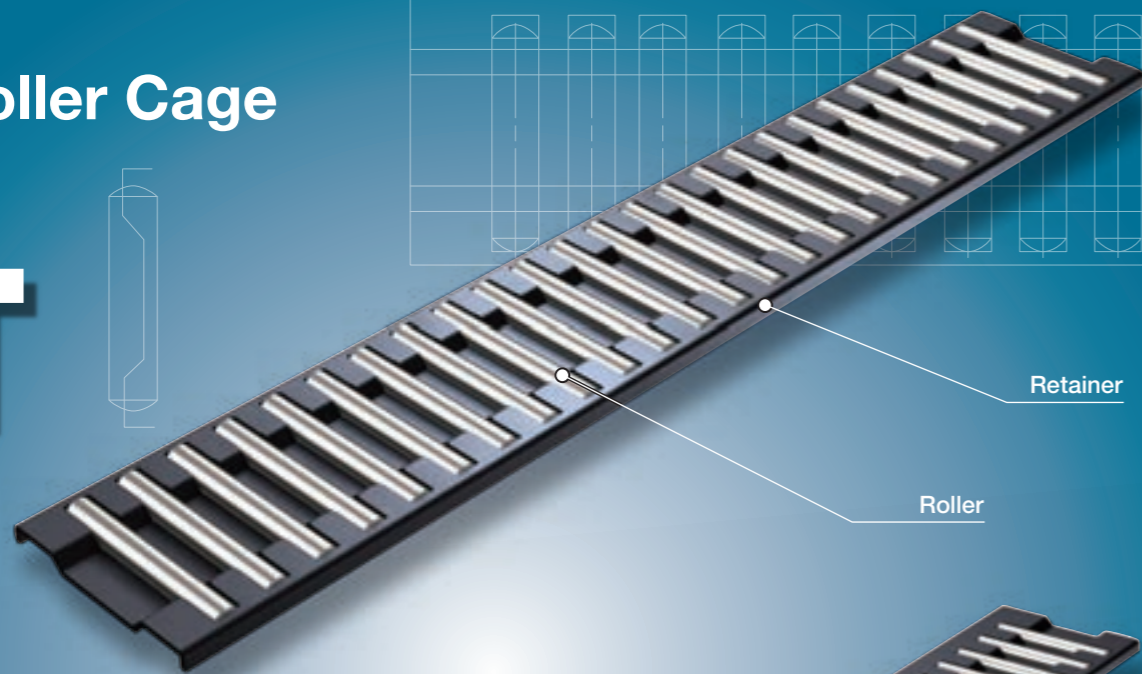

FTW...A

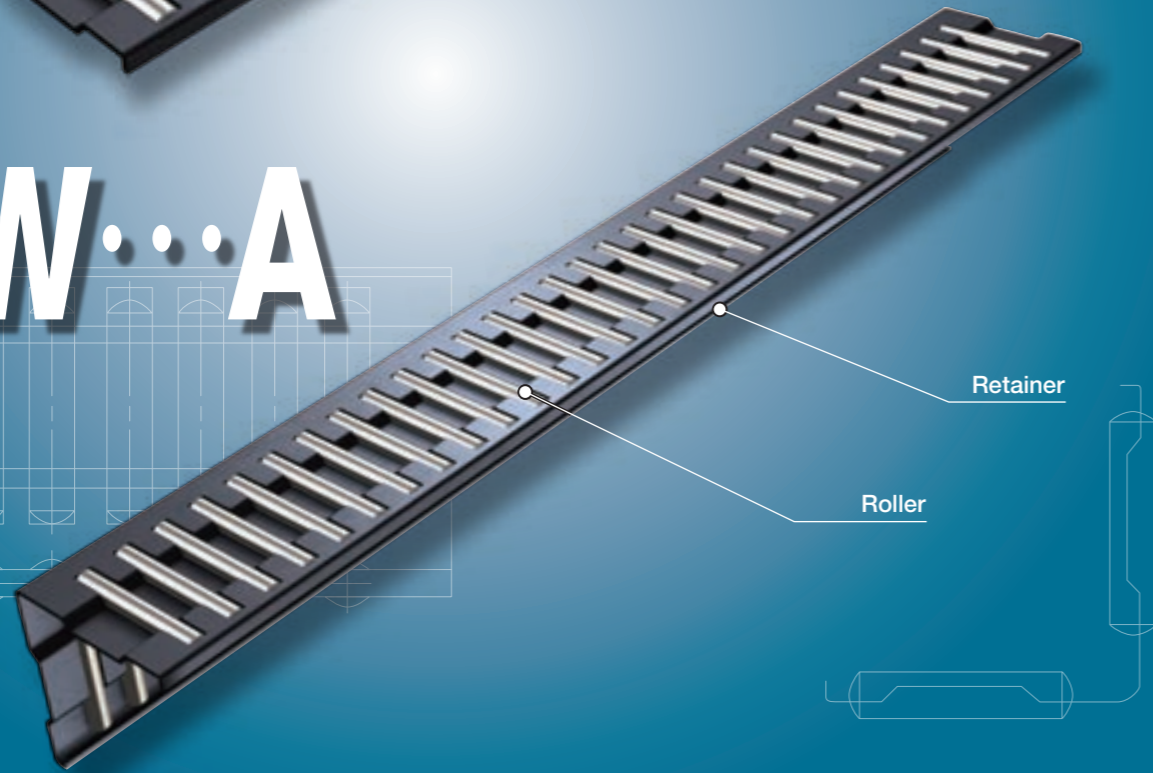

Points

1 Low section

Flat Roller Cage is a limited linear motion guide consisting of high accuracy rollers and a very precise retainers and features low cross sectional height which is as high as the roller diameter.

2 Large load rating

Rollers are assembled in a cage with a small pitch distance, so load ratings are large and the rigidity is high.

3 Simple replacement for rolling guide

A single row model and a double row model with a 90° are standardized and can be easily used to modify the conventional plain guide ways of machine tools, etc. into a rolling guide type without a large-scale redesign of the bed.

4 Smooth operations and low noise

As a retainer processed with high accuracy guides the rollers, the frictional resistance is very low without stick-slip, and stable linear motion is obtained. Retainers made of synthetic resin are most suitable for applications where low noise is required.

5 Easy handling

The rollers are caged in a retainer securely, allowing easy handling.

Identification Number and Specification

Example of an identification number

The specification of FT and FTW...A are indicated by the identification number. Indicate the identification number, consisting of a model code, dimensions, a supplemental code, and a selection code for each specification to apply.

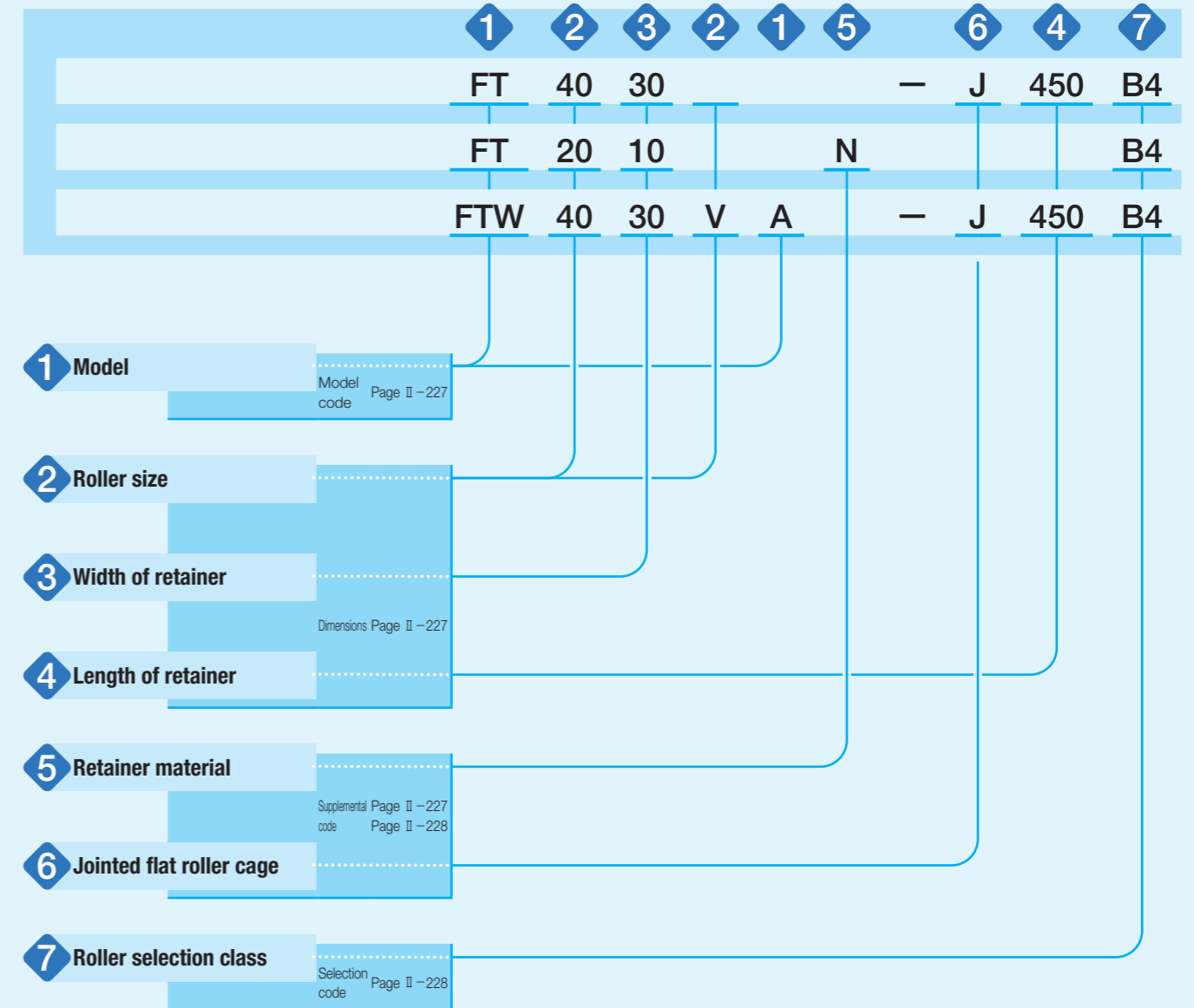

RW · SR · GSN
FT · FTW...A

1 Model
 Flat Roller Cage
 Single row type : FT
 Double row angle type : FTW...A
 For applicable models and roller sizes, see Table 1.

2 Roller size
 Indicate 10 times as large value as the roller diameter (mm).
 Indicate $10\sqrt{2}$ times as large integer value as roller diameter (mm) for those with code V.

Table 1 Models and sizes of FT and FTW...A

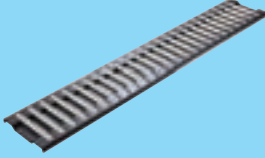
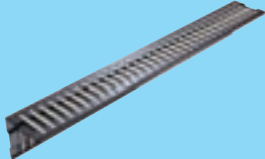
Shape	Retainer material	Model	Roller size							
			20	25	30	35	40	50	100	200
Single row type 	Steel made	FT	○	○	○	○	○	○	○	○
	Synthetic resin made	FT...N	○	○	○	○	-	-	-	-
Double row angle type 	Steel made	FTW...A	-	-	-	-	○	○	○	○

3 Width of retainer
 Indicate the width of retainer in mm.

4 Length of retainer
 Indicate the length of retainer in mm.
 Length other than the standard length stated in the dimension table can be prepared upon request.
 Contact **IKO** for further information.

5 Retainer material
 Steel made : No symbol Specify the retainer material.
 Synthetic resin made : N For applicable models and roller sizes, see Table 1.

6 Jointed flat roller cage
 Standard length : No symbol Indicate full length of the retainer as well and specify ones longer than the standard length.
 Jointed flat roller cage : J

Flat Roller Cage with extended full length can be produced by connecting steel made retainers each other. If needed, please specify a retainer full length in mm after the supplemental code "J" following the way indicated in the example of an identification number. Maximum length of a jointed flat roller cage is indicated in Table 2.
 Length longer than the maximum stated in Table 2 can be prepared upon request. Contact **IKO** for further information.

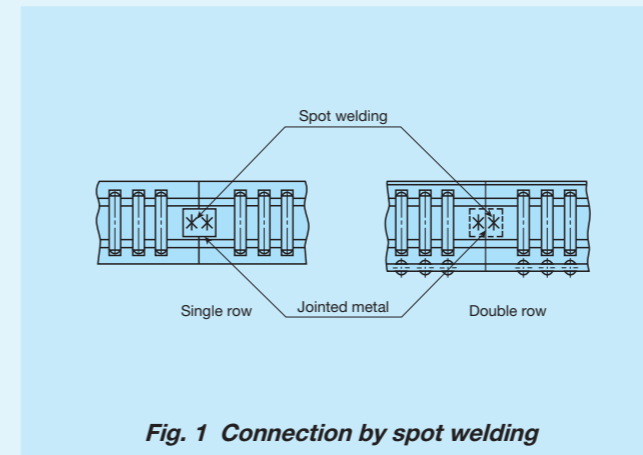

Fig. 1 Connection by spot welding

Table 2 Maximum length of jointed flat roller cage unit: mm

Identification number	Maximum length of retainer
FT 2010	300
FT 2515	
FT 3020	
FT 3525	375
FT 4030	
FT 4035	600
FT 4026 V	
FT 5038	1 000
FT 5043	
FT 5030 V	
FT 10080	
FT 10060 V	
FT 200120	
FT 200100 V	1 000
FTW 4030 VA	
FTW 5045 A	1 000
FTW 5050 A	
FTW 5035 VA	
FTW 10095 A	1 500
FTW 10070 VA	
FTW 200150 A	
FTW 200120 VA	

7 Roller selection class
 For roller selection classes and tolerances of dimensions for roller diameters, see Table 3.

Tolerances of dimensions for roller diameters are indicated in Table 3. Normally, one of the standard selection classes is delivered.
 To achieve accurate load distribution, it is necessary to combine products with the same selection code. If needed, please specify it following the way indicated in the example of an identification number.

Table 3 Roller selection class unit: μm

Selection class	Selection code	Average tolerances of dimensions for roller diameters ⁽¹⁾
Standard	B2	0 ~ -2
	B4	-2 ~ -4
	B6	-4 ~ -6
	B8	-6 ~ -8
Semi-standard	A1	0 ~ -1
	A2	-1 ~ -2
	A3	-2 ~ -3
	A4	-3 ~ -4
	A5	-4 ~ -5
	A6	-5 ~ -6

Note ⁽¹⁾ Allowance of roundness and cylindricity follows JIS B 1506:2005 roller bearing - roller.

Precaution for Use

1 Raceway

Recommended values for surface hardness and roughness of mating raceway are shown in Table 4 and the recommended value for the minimum effective hardening depth is shown in Table 5.

Table 4 Surface hardness and roughness of raceway

Item	Recommended value	Remark
Surface hardness	58~64HRC	When the surface hardness is low, multiply the load rating by hardness factor (1).
Surface roughness	0.2 μmRa or lower (0.8 μmRy or lower)	Where accuracy standard is low, around 0.8 μmRa (3.2 μmRy) is also allowed.

Note (1) For hardness factor, refer to Fig. 3 in page III-5.

Table 5 Minimum effective hardening depth of raceway
unit: mm

Roller diameter		Recommended value for minimum effective hardening depth
Over	Incl.	
—	3	0.5
3	4	0.8
4	5	1.0
5	8	1.5
8	10	2.0
10	14.142	2.5
14.142	20	3.5

2 When used for bed surface and 90° V surface

After complete lapping as indicated in Fig. 2, mount FT to FTW...VA, or FT...V to FTW...A. Combination of Flat Roller Cage at this point is indicated in Table 6.

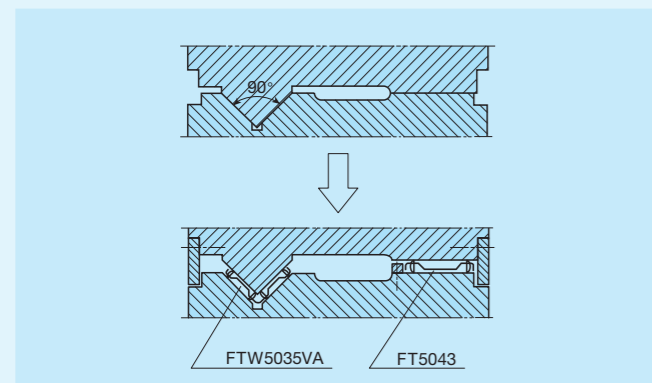

Fig. 2 Example of use on flat surface and 90° V surface

3 Stroke length and retainer length

Movement in a linear direction as in Fig. 3 will move the Flat Roller Cage in the same direction by one half of the movement amount. Therefore, way length, stroke length and retainer length are correlated as follows:

$$L_1 = \frac{S}{2} + L \dots \dots \dots (1)$$

where, L_1 : Way length, mm
 S : Stroke length, mm
 L : Retainer length, mm

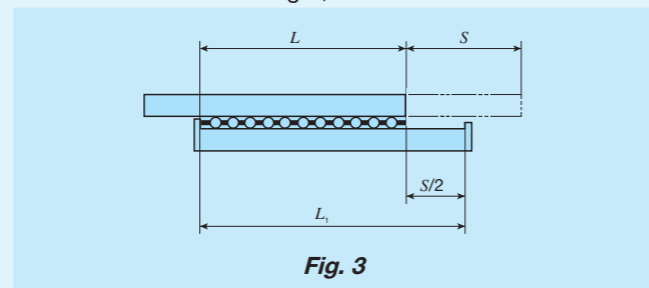

4 Operating temperature

If the retainer is made of steel, it can withstand higher temperature. However, if you use it in an environment exceeding 100°C, please contact **IKO**.

The retainer made of synthetic resin can withstand up to 100°C. For continuous operation, please keep it under 80°C.

Precaution for Mounting

FT and FTW...A are typically mounted as indicated in Fig. 4. When the heat-treated and polished way is mounted to the device body, you must be careful not to make deformation by tightening.

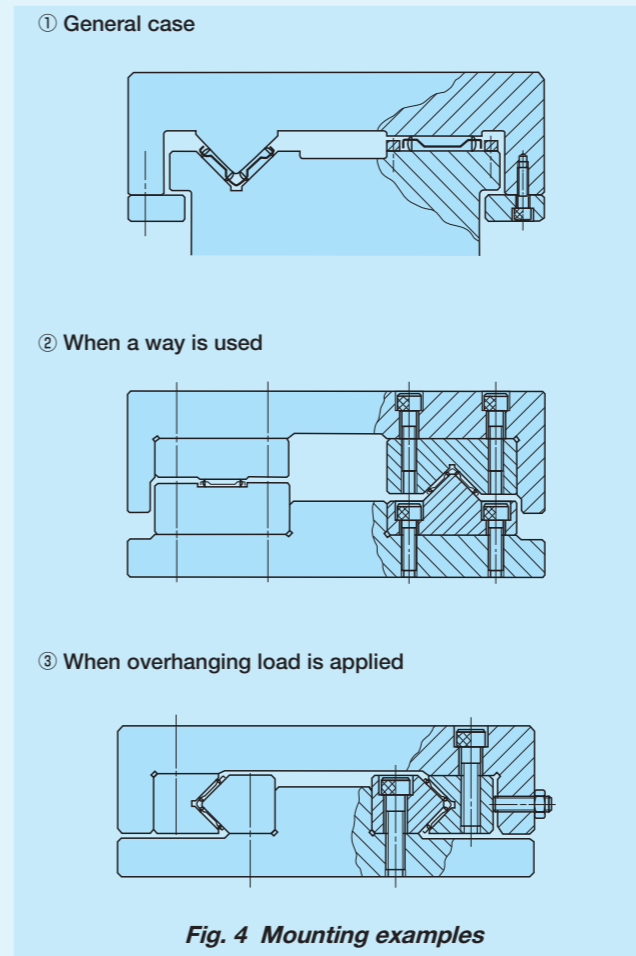

Fig. 4 Mounting examples

Table 6 Combination of Flat Roller Cage

Combination Number	For flat surface		For 90° V surface	
	Identification number	Roller diameter D_w	Identification number	Roller diameter D_w
1	FT 4030	4	FTW 4030 VA	2.828
2	FT 4035	4	FTW 4030 VA	2.828
3	FT 5038	5	FTW 5035 VA	3.535
4	FT 5043	5	FTW 5035 VA	3.535
5	FT 10060 V	7.071	FTW 5045 A	5
6	FT 10060 V	7.071	FTW 5050 A	5
7	FT 10080	10	FTW 10070 VA	7.071
8	FT 200100 V	14.142	FTW 10095 A	10
9	FT 200120	20	FTW 200120 VA	14.142

unit: mm

IKO Flat Roller Cage

Single row type Flat Roller Cage

Shape	FT			
Size	20	25	30	35
	40	50	100	200

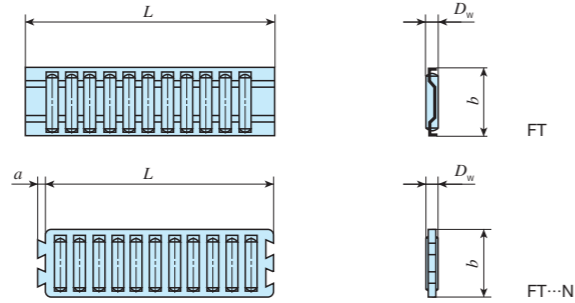

Double row angle type Flat Roller Cage

Shape	FTW...A			
Size	—	—	—	—
	40	50	100	200

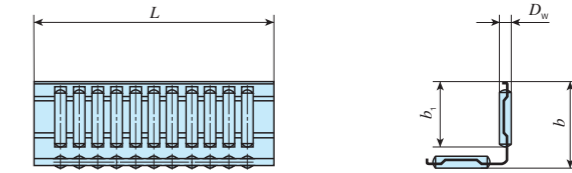

Identification number		Mass (Ref.) g	Nominal dimensions mm				Basic dynamic load rating C N	Basic static load rating C ₀ N	
Steel retainer	Synthetic resin retainer		D _w	b	L	a			
—	FT 2010 N	1.63	2	10	32	2	8 660	19 800	
FT 2010 - 32	—	1.91			—	—	—	9 710	22 900
FT 2010 - 100	—	5.8			100	—	—	22 900	68 700
—	FT 2515 N	4.3	2.5	15	45	2.5	17 300	41 100	
FT 2515 - 45	—	5.6			—	—	—	22 000	56 200
FT 2515 - 100	—	11.6			100	—	—	37 900	112 000
—	FT 3020 N	9.7	3	20	60	3	31 600	78 800	
FT 3020 - 60	—	12.5			—	—	—	37 100	96 700
—	FT 3525 N	18.6			75	3.5	—	51 400	132 000
FT 3525 - 75	—	23	3.5	25	75	—	58 400	155 000	
FT 4030 - 150	—	73			30	—	—	127 000	382 000
FT 4035 - 150	—	86			35	150	—	143 000	446 000
FT 4026V - 150	—	45	2.828	26	150	—	97 300	347 000	
FT 5038 - 250	—	195	5	38	250	—	267 000	851 000	
FT 5043 - 250	—	200					43	306 000	1 020 000
FT 5030V - 250	—	103	3.535	30	250	—	180 000	652 000	
FT 10080 - 500	—	1 610	10	80	500	—	1 390 000	4 370 000	
FT 10060V - 500	—	870	7.071	60	500	—	838 000	2 900 000	
FT 200120 - 500	—	4 940	20	120	500	—	3 120 000	7 670 000	
FT 200100V - 500	—	2 860	14.142	100	500	—	2 090 000	5 820 000	

Identification number		Mass (Ref.) g	Nominal dimensions mm				Basic dynamic load rating C N	Basic static load rating C ₀ N
Steel retainer	Synthetic resin retainer		D _w	b	L	b ₁		
FTW 4030 VA - 150	—	94	2.828	30	150	24.5	118 000	491 000
FTW 5045 A - 250	—	410	5	45	250	35.5	332 000	1 240 000
FTW 5050 A - 250	—	460		50		40.5	371 000	1 440 000
FTW 5035 VA - 250	—	220	3.535	35	250	29	218 000	922 000
FTW 10095 A - 500	—	3 360	10	95	500	77	1 680 000	6 180 000
FTW 10070 VA - 500	—	1 790	7.071	70	500	56.5	1 020 000	4 110 000
FTW 200150 A - 500	—	10 200	20	150	500	118	3 790 000	10 800 000
FTW 200120 VA - 500	—	5 940	14.142	120	500	96	2 530 000	8 220 000

General Explanation



Load Rating and Life

Life of linear motion rolling guides

Even in normal operational status, a linear motion rolling guide will reach the end of its life after a certain period of operations. As repeated load is constantly applied onto a raceway and rolling elements of the linear motion rolling guide, this leads to leprous damage (scale-like wear fragments) called fatigue flaking due to rolling contact fatigue of materials, it will be unusable at the end. Total traveling distance before occurrence of this fatigue flaking on a raceway or rolling elements is called the life of linear motion rolling guide. As the life of linear motion rolling guide may vary depending on material fatigue phenomenon, rating life based on statistic calculation is used.

Rating life

Rating life of linear motion rolling guide refers to the total traveling distance ⁽¹⁾ 90% of a group of the same linear motion rolling guide can operate without linear motion rolling guide material damages due to rolling contact fatigue when they are operated individually under the same conditions.

Note ⁽¹⁾ Stroke Rotary Bushing is represented as total number of rotations.

Basic dynamic load rating C

Basic dynamic load rating refers to load with certain direction and size that is logically endurable for rating life indicated in Table 1 when a group of the same linear motion rolling guides is operated individually under the same conditions.

Table 1 Load rating

Series	Rating life
Crossed Roller Way Roller Way & Flat Roller Cage	100×10 ³ m
Linear Slide Unit Linear Ball Spline Linear Bushing	50×10 ³ m
Stroke Rotary Bushing	10 ⁶ rotations

Basic static load rating C_0

Basic static load rating refers to static load generating a certain contact stress at the center of contact parts of the rolling elements and a raceway under maximum load, which is the load at the allowable limit for normal rolling motion. Generally, it is used considering static safety factor.

Allowable load F

Allowable load refers to load of smooth rolling motion on contact surface to which maximum contact stress is applied and the sum of whose elastic deformation of rolling elements and raceway is small. Therefore, use applied load within the allowable load range if very smooth rolling motion and high accuracy are required.

Dynamic torque rating T

Dynamic torque rating refers to a torque with a certain direction and size with which 90% of a group of the same linear ball splines can run 50 x 10³m without material damages due to rolling contact fatigue when they are operated individually.

Static torque rating T_0 Static moment rating T_0, T_x, T_y

Static torque rating and static moment rating refer to static torque or moment load generating a certain level of contact stress at the center of contact parts of rolling elements and a raceway under the maximum load when the torque or moment load (see Fig. 1) are loaded, which is the torque or moment load at the allowable limit for normal rolling motion. Generally, it is used considering static safety factor.

Load direction and load rating

Linear motion rolling guide is used with its load rating corrected in accordance to the load direction. Basic dynamic load rating and basic static load rating indicated in the dimension table should be corrected before use. As the values to be corrected vary depending on series, please see an explanation for each series.

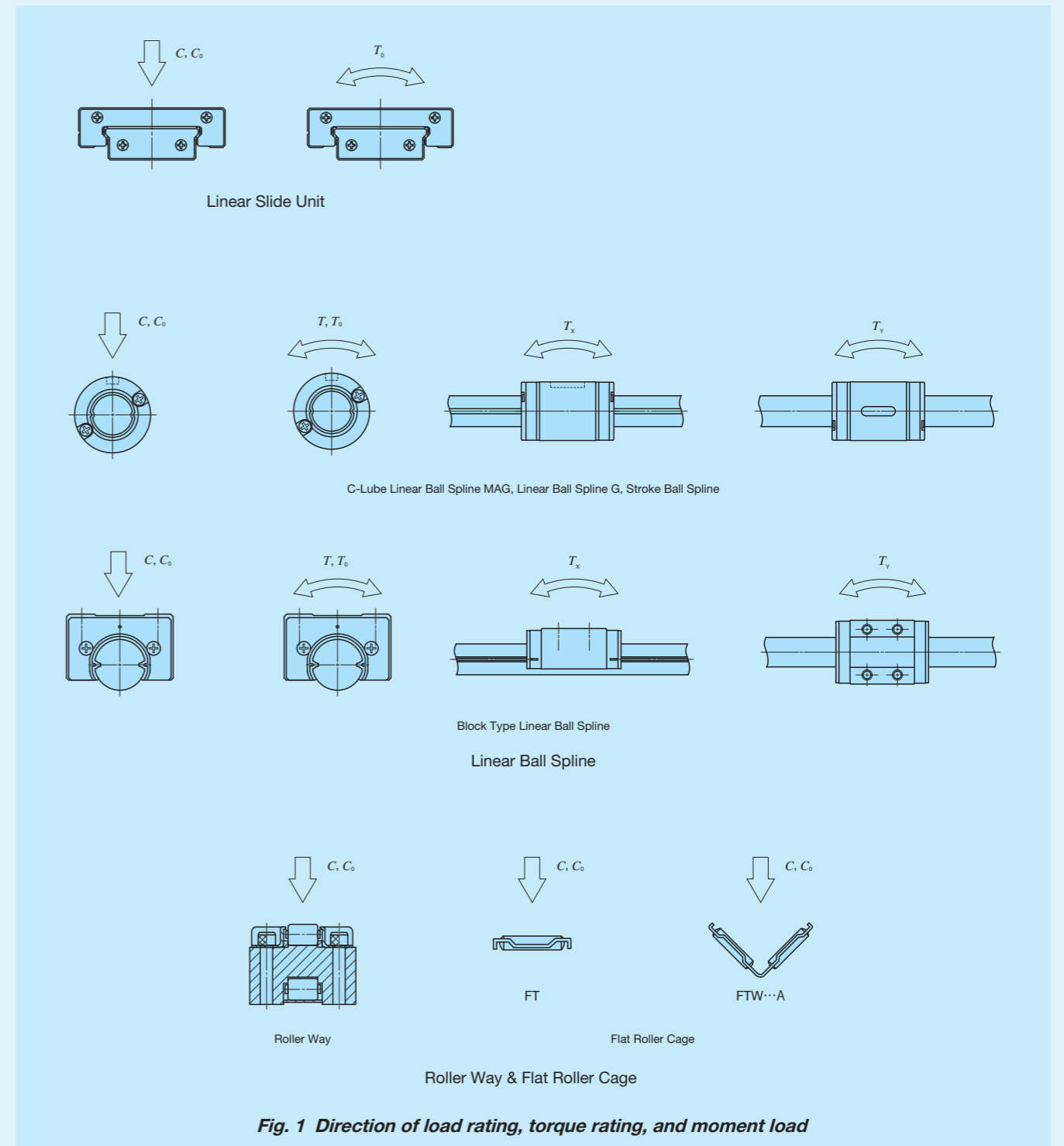

Remark: For the cases of Crossed Roller Way and Linear Bushing, see an explanation of each series.

Calculating formula of life

Rating life and basic dynamic load rating of a linear motion rolling guide are correlated as indicated in Table 2.1 and Table 2.2.

Table 2.1 Calculating formula of life for each series

Series	Calculating formula of rating life		Code description
	Total traveling distance 10 ³ m	Life length h	
Crossed Roller Way Roller Way & Flat Roller Cage	$L=100\left(\frac{C}{P}\right)^{\frac{10}{3}}$	$L_h = \frac{10^6 L}{2Sn_1 \times 60}$	<i>L</i> : Rating life, 10 ³ m <i>C</i> : Basic dynamic load rating, N <i>T</i> : Dynamic torque rating, N·m <i>P</i> : Dynamic equivalent load (or applied load), N <i>M</i> : Applied torque N·m <i>L_h</i> : Rating life in hours h <i>S</i> : Stroke length mm <i>n₁</i> : Number of strokes per minute cpm
Linear Slide Unit Linear Bushing	$L=50\left(\frac{C}{P}\right)^3$		
Linear Ball Spline	$L=50\left(\frac{C}{P}\right)^3$ $L=50\left(\frac{T}{M}\right)^3$		

Table 2.2 Calculating formula of life for Stroke Rotary Bushing

Series	Calculating formula of rating life		Code description
	Total number of rotation 10 ⁶ rotations	Life length h	
Rotational motion	$L = \left(\frac{C}{P}\right)^3$	$L_h = \frac{10^6 L}{60 \sqrt{(D_{PW} n)^2 + (10 S n_1)^2} / D_{PW}}$	<i>L</i> : Rating life, 10 ⁶ rotations <i>C</i> : Basic dynamic load rating, N <i>P</i> : Applied load N <i>L_h</i> : Rating life in hours h <i>n</i> : Rotational speed rpm <i>n₁</i> : Number of strokes per minute cpm <i>S</i> : Stroke length mm <i>D_{PW}</i> : Pitch circle diameter of balls mm ($D_{PW} \approx 1.15 F_w$) <i>F_w</i> : Inscribed circle diameter mm
Rotational and rotary compound motion			
Rotary and linear motion		$L_h = \frac{10^6 L}{600 S n_1 (\pi D_{PW})}$	

Temperature factor

As the allowable contact stress is decreased at operating temperature above 150°C, the basic dynamic load rating should be corrected by the following equation:

$$C_t = f_t C \dots\dots\dots(1)$$

where, *C_t* : Basic dynamic load rating taking into account temperature increase, N
f_t : Temperature factor (see Fig. 2)
C : Basic dynamic load rating, N

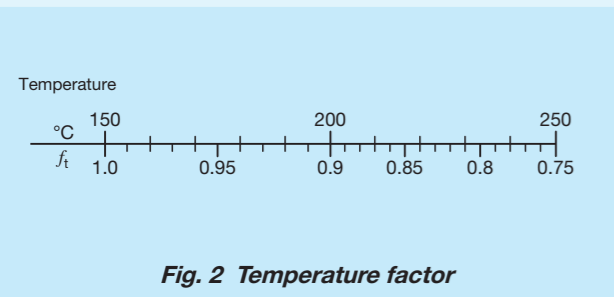

Hardness factor

Hardness of a raceway must be 58 to 64 HRC. When it is lower than 58 HRC, correct basic dynamic load rating by the following equation:

$$C_H = f_H C \dots\dots\dots(2)$$

where, *C_H* : Basic dynamic load rating taking into account the hardness, N
f_H : Hardness factor (see Fig. 3)
C : Basic dynamic load rating, N

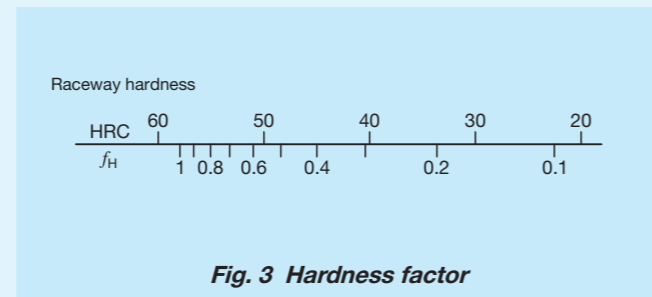

Load factor

Load applied to a linear motion rolling guide can be larger than theoretical load due to machine vibration or shock. Generally, the applied load is obtained by multiplying it by the load factor indicated in Table 3.

Table 3 Load factor

Operating conditions	<i>f_w</i>
Smooth operation free from shock	1 ~1.2
Normal operation	1.2~1.5
Operation with shock load	1.5~3

Static safety factor

Generally, basic static load rating and static moment rating (or static torque rating) is considered as load at the allowable limit for normal rolling motion. However, static safety factor must be considered according to operating conditions and required performance of the linear motion rolling guide.

Static safety factor can be obtained by the following equation and typical values are indicated in Table 4.

Equation (4) is a representative equation for moment load or torque. Static moment rating and maximum moment load in each direction is applied for the calculation.

$$f_s = \frac{C_0}{P_0} \dots\dots\dots(3)$$

$$f_s = \frac{T_0}{M_0} \dots\dots\dots(4)$$

where, *f_s* : Static safety factor
C₀ : Basic static load rating, N
P₀ : Static equivalent load, N
 (Or applied load (maximum load))
T₀ : Static moment rating, N·m
 (Or static torque rating)
M₀ : Moment load or torque in each direction, N·m
 (Maximum moment load or maximum torque)

Table 4 Static safety factor

Series	Operational condition and static safety factor		
	Operation with vibration and/or shock	High operating performance	Normal operating conditions
Crossed Roller Way	4 ~6	3~5	2.5~3
Linear Slide Unit	3 ~5	2~4	1 ~3
Linear Ball Spline	5 ~7	4~6	3 ~5
Linear Bushing	2.5	2	1.5
Stroke Rotary Bushing	2.5	2	1.5
Roller Way & Flat Roller Cage	4 ~6	3~5	2.5~3

Preload

Objectives of preload

In some cases, the linear motion rolling guide is used with clearance given to the linear motion rolling guide when light motion with small load is required. However, for some applications it may be used with play in the guiding mechanism removed or with preload to increase rigidity.

Preload is applied to the contact parts of a raceway and rolling elements with internal stress generated in advance. When an external load is applied on the preloaded linear motion rolling guide, shock absorbing with this internal stress makes elastic deformation smaller, and its rigidity is increased. (See Fig.4)

Preload setting

Preload amount is determined by considering the characteristics of the machines or equipments on which the linear motion rolling guide is mounted and the nature of load acting on the linear motion rolling guide. The standard amount of preload for linear motion rolling guides is, in general, approx. 1/3 of load when the rolling elements are balls (steel balls) and approx. 1/2 of load when they are rollers (cylindrical rollers). If the linear motion rolling guides are required to have very high rigidity to withstand vibration or fluctuating load, a larger preload may be applied.

Precaution for preload selection

Even when high rigidity must be required, excessive preload should be avoided, because it will produce an excessive stress between rolling elements and raceways, and eventually result in short life of linear motion rolling guides. It is important to apply a proper amount of preload, considering the operational conditions. When using with a large preload, contact **IKO**. Linear Bushing and Stroke Rotary Bushing should never be given a large amount of preload.

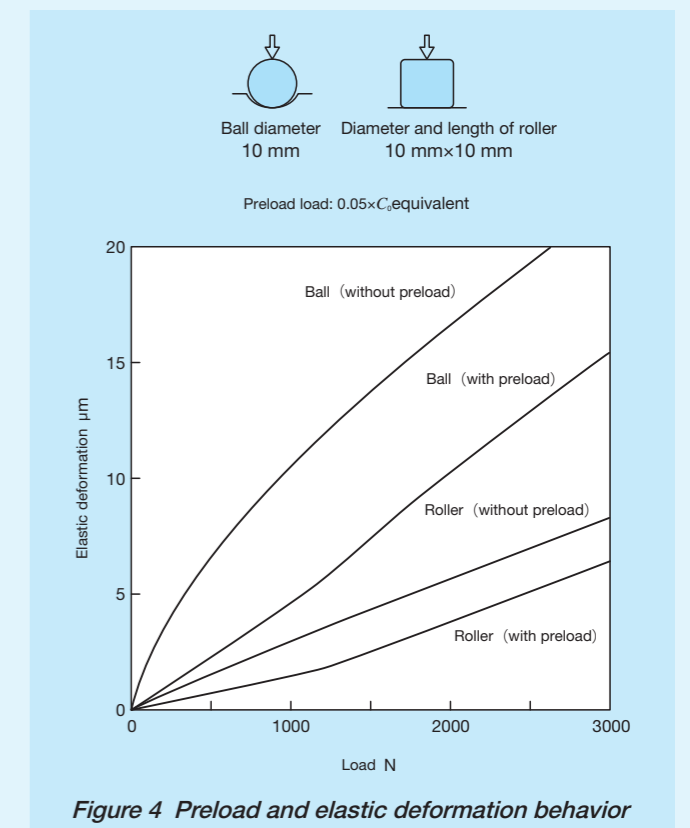

Figure 4 Preload and elastic deformation behavior

1N=0.102kgf=0.2248lbs.
 1mm=0.03937inch

Friction of linear motion rolling guide

The static friction (start-up friction) of linear motion rolling guides is much lower than that of conventional plain guides. Also, the difference between static friction and dynamic friction is small, and frictional resistance varies little when velocity changes. These are excellent features of linear motion rolling guides, and account for their ability to reduce power consumption, suppress operating temperature rise, and increase traveling speed. Since frictional resistance and variation are small, high speed response characteristics to motion commands and high accuracy positioning can be achieved.

Friction coefficient

The frictional resistance of linear motion rolling guides varies with their model, applied load, velocity and characteristics of lubricant. Generally, lubricant or seals are major factors in determining the frictional resistance in light load or high speed operation, while the amount of load is the major factor in heavy load or low speed operation. The frictional resistance of linear motion rolling guides depends on various factors, but generally the following formula is used.

$$F = \mu P \dots\dots\dots(3)$$

where, F : Frictional resistance, N
 μ : Dynamic friction coefficient
 P : Applied load, N

For sealed guides, seal resistance is added to the above value, but this resistance varies greatly depending on the interference amount of seal lip and lubrication conditions. Where the lubrication and mounting condition are correct and the load is moderate, the friction coefficients of linear motion rolling guide in operation are within the range shown in Table 5. Generally, friction coefficient is large under small load.

Table 5 Friction coefficient

Series name	Dynamic friction coefficient μ (1)
Crossed Roller Way	0.0010~0.0030
Linear Slide Unit	0.0010~0.0020
Linear Ball Spline	0.0020~0.0040
Linear Bushing	0.0020~0.0030
Stroke Rotary Bushing	0.0006~0.0012
Roller Way	0.0020~0.0040
Flat Roller Cage	0.0010~0.0030

Note (1) These friction coefficients do not include seal.

Objectives of lubrication

The objectives of applying lubricant for linear motion rolling guides is to keep raceways, rolling elements, etc. in a linear motion rolling guide from metal contact, and thereby reduce friction and wear preventing heat generation and seizure. When an adequate oil film is formed at the rolling contact area between the raceways and rolling elements, the contact stress due to load can be reduced. To manage the formation of adequate oil film is important for ensuring the reliability of linear motion rolling mechanism.

Selection of lubricant

To obtain the full performance of linear motion rolling guides, it is necessary to select an appropriate lubricant and lubrication method by considering the model, load and velocity of each linear motion rolling guide. However, as compared with plain guides, lubrication of linear motion rolling guides is much simpler. Only a small amount of lubrication oil is needed and replenishment interval is longer, so maintenance can be greatly reduced. Grease and oil are the two most commonly used lubricants for linear motion rolling guides.

Grease lubrication

For linear motion rolling guides, lithium-soap base grease (Consistency No.2 of JIS) is commonly used. For rolling guides operating under heavy load conditions, grease containing extreme pressure additives is recommended. In clean and high-vacuum environments, where low dust generating performance and low vaporization characteristics are required, greases containing a synthetic-base oil or a soap other than the lithium-soap base are used. For applications in these environments, due consideration is necessary to select a grease that is suitable for the operating conditions of linear motion rolling guide and achieves satisfactory lubrication performance at the same time.

Table 6 Pre-packed grease list

Series name	Pre-packed grease
C-Lube Linear Ball Spline MAG Linear Ball Spline G	Alvania EP Grease 2 [SHOWA SHELL SEKIYU K. K.]
Block Type Linear Ball Spline	MULTEMP PS No.2 [KYODO YUSHI CO., LTD.]

Grease replenishment interval

The quality of any grease will gradually deteriorate as operating time passes. Therefore, periodic replenishment is necessary. Grease replenishment interval varies depending on the operating conditions. A six month interval is generally recommended, and if the machine operation consists of reciprocating motions with many cycles and long strokes, replenishment every three month is recommended. In addition, linear motion rolling guides in which the lubrication part "C-Lube" is built deliver long-term maintenance free performance. This eliminates the need for lubrication mechanism and workload which used to be necessary for linear motion rolling guides and significantly reduces maintenance cost.

Grease replenishment method

New grease must be supplied through a grease feed device such as a grease nipple until old grease is discharged. After grease is replenished, running-in is performed and excess grease will be discharged to outside of the linear motion rolling guide. Discharged grease must then be removed before starting the operation. The amount of grease required for standard replenishment is about 1/3 to 1/2 of the free space inside the linear motion rolling guide. When grease is supplied from a grease nipple for the first time, there will be grease lost in the replenishment path. The amount lost should be taken into consideration. Generally, immediately after grease is replenished, frictional resistance tends to increase. If additional running-in is performed for 10 to 20 reciprocating cycles after excess grease is discharged, frictional resistance becomes small and stable. For applications where low frictional resistance is required, the replenishment amount of grease may be reduced, but it must be kept to an appropriate level so as not to give a bad influence on the lubrication performance.

Mixing of different type of grease

Mixing different types of grease may result in changing the properties of base oil, soap base, or additives used, and, in some cases, severely deteriorate the lubrication performance or cause trouble due to chemical changes of additives. Old grease should therefore be removed thoroughly before filling with new grease.

Table 7 Grease brands used in linear motion rolling guide

Brand	Base oil	Thickener	Range of operating temperature (°) °C	Usage
Alvania EP Grease 2	[SHOWA SHELL SEKIYU K. K.] Mineral oil	Lithium	-20~110	General application with extreme-pressure additive
Alvania Grease S2	[SHOWA SHELL SEKIYU K. K.] Mineral oil	Lithium	-25~120	General application
Multemp PS No.2	[KYODO YUSHI CO., LTD.] Synthetic oil, Mineral oil	Lithium	-50~130	General application
IKO Low Dust-Generation Grease for Clean Environment CG2	[NIPPON THOMPSON CO., LTD.] Synthetic oil	Urea	-40~200	For clean environment Long life
IKO Low Dust-Generation Grease for Clean Environment CGL	[NIPPON THOMPSON CO., LTD.] Synthetic oil, Mineral oil	Lithium / Calcium	-30~120	For clean environment Low sliding
DEMNUM™ Grease L-200 (1)	[DAIKIN INDUSTRIES, LTD.] Synthetic oil	Ethylene tetra-fluoride	-60~300	For clean environment
FOMBLIN® Y-VAC3 (1)	[SOLVAY SOLEXIS] Synthetic oil	Ethylene tetra-fluoride	-20~250	For vacuum
IKO Anti-Fretting Grease AF2	[NIPPON THOMPSON CO., LTD.] Synthetic oil	Urea	-50~170	Fretting-proof
6459 Grease N	[SHOWA SHELL SEKIYU K. K.] Mineral oil	Poly-urea	-	Fretting-proof

Notes (1) Set replenishment intervals to short.

(2) The Ranges of operating temperature are quoted from the grease manufacturer's cataloged values, but do not guarantee regular use under high temperature environment.

Remarks 1. FOMBLIN® is a registered trademark of SOLVAY SOLEXIS.
 2. Check with the chosen grease manufacturer's catalog before use.
 For grease for use other than listed, contact **IKO**.

Oil lubrication

For oil lubrication, heavy load requires high oil viscosity and high velocity requires low oil viscosity. Generally, for linear motion rolling guides operating under heavy load, lubrication oil with a viscosity of about 68 mm²/s is used. For linear motion rolling guides under light load at high speed operation, lubrication oil with a viscosity of about 13 mm²/s is used.

Lubrication part "C-Lube"

C-Lube Linear Ball Spline MAG has built-in lubrication part, "C-Lube". C-Lube is a porous resin with molding formed fine resin powder. It is a lubrication part impregnated with a large amount of lubrication oil in its open pores by capillary inside. Lubrication oil is supplied directly to balls (steel balls), not to the spline shaft. When the balls have contact with C-Lube built in the external cylinder, lubrication oil is supplied to the surface of the balls. As the steel balls circulate, the lubricant is distributed to the loading area along the track rail. This results in adequate lubrication oil being properly maintained in the loading area and lubrication performance will last for a long time. The surface of C-Lube is always covered with the lubrication oil. Lubrication oil is continuously supplied to the surface of steel balls by surface tension in the contact of C-Lube surface and steel balls.

Statements

● Unit Conversion Rate Table

SI, CGS series and gravity system unit cross-reference table

Amount Unit system	Length	Mass	Time	Acceleration	Force	Stress and pressure
SI	m	kg	s	m/s ²	N	Pa
CGS series	cm	g	s	Gal	dyn	dyn/cm ²
Gravity system	m	kgf·s ² /m	s	m/s ²	kgf	kgf/m ²

SI unit conversion

Amount	Unit name	Code	SI conversion rate	SI unit name	Code
Angle	D	°	$\pi/180$	Radian	rad
	Min	'	$\pi/10\ 800$		
	Sec	"	$\pi/648\ 000$		
Length	Meter	m	1	Meter	m
	Micron	μ	10^{-6}		
	Angstrom	Å	10^{-10}		
	X ray unit		$\approx 1.002\ 08 \times 10^{-13}$		
	Nautical mile	n mile	1852		
Area	Square meter	m ²	1	Square meter	m ²
	Are	a	10^2		
	Hectare	ha	10^4		
Volume	Cubic meter	m ³	1	Cubic meter	m ³
	Liter	l, L	10^{-3}		
Mass	Kilogram	kg	1	Kilogram	kg
	Ton	t	10^3		
	Atomic mass unit	u	$\approx 1.660\ 57 \times 10^{-27}$		
Time	Sec	s	1	Sec	s
	Min	min	60		
	Hr	h	3 600		
	Day	d	86 400		
Velocity	Meter per second	m/s	1	Meter per second	m/s
	Knot	kn	$1\ 852/3\ 600$		
Frequency and vibration	Number of cycle	s ⁻¹	1	Hertz	Hz
Number of rotations	Rotation per minute	rpm	1/60	Per second	s ⁻¹
Angular velocity	Radian per second	rad/s	1	Radian per second	rad/s
Acceleration	Meter per second	m/s ²	1	Meter per second	m/s ²
	G	G	9.806 65		
Force	Weight in kg	kgf	9.806 65	Newton	N
	Weight in ton	tf	9 806.65		
	Dyne	dyn	10^{-5}		
Force moment load	Weight in kg meter	kgf·m	9.806 65	Newton meter	N·m
Stress and pressure	Weight in kg per square meter	kgf/m ²	9.806 65	Pascal	Pa
	Weight in kg per square cm	kgf/cm ²	$9.806\ 65 \times 10^4$		
	Weight in kg per square mm	kgf/mm ²	$9.806\ 65 \times 10^6$		

Energy	Power	Temperature	Viscosity	Kinetic viscosity	Flux	Flux density	Magnetic field intensity
J	W	K	Pa·s	m ² /s	Wb	T	A/m
erg	erg/s	°C	P	St	Mx	Gs	Oe
kgf·m	kgf·m/s	°C	kgf·s/m ²	m ² /s	—	—	—

Amount	Unit name	Code	SI conversion rate	SI unit name	Code
Pressure	Meter water column	mH ₂ O	9 806.65	Pascal	Pa
	millimeter of mercury column	mmHg	$101\ 325/760$		
	Torr	Torr	$101\ 325/760$		
	Air pressure	atm	101 325		
	Bar	bar	10^5		
Energy	Erg	erg	10^{-7}	Joule	J
	IT calorie	cal _{IT}	4.186 8		
	Weight in kg meter	kgf·m	9.806 65		
	Kilowatt per hour	kW·h	3.600×10^6		
	French horse-power per hour	PS·h	$\approx 2.647\ 79 \times 10^6$		
Electron volt	eV	$\approx 1.602\ 19 \times 10^{-19}$			
Power and motivity	Watt	W	1	Watt	W
	French horse-power	PS	≈ 735.5		
	Weight in kg meter per second	kgf·m/s	9.806 65		
Viscosity	Poise	P	10^{-1}	Pascal second	Pa·s
	Centipoise	cP	10^{-3}		
	Weight in kg second per square meter	kgf·s/m ²	9.806 65		
Kinetic viscosity	Stokes	St	10^{-4}	Square meter per second	m ² /s
	Centistokes	cSt	10^{-6}		
Temperature	D	°C	+273.15	Kelvin	K
Radioactivity	Curie	Ci	3.7×10^{10}	Becquerel	Bq
	Exposure radiation dose	Roentgen	2.58×10^{-4}		
	Absorbed dose	Rad	10^{-2}		
	Dose equivalent	Rem	10^{-2}		
Flux	Maxwell	Mx	10^{-8}	Weber	Wb
Flux density	Gamma	γ	10^{-9}	Tesla	T
	Gauss	Gs	10^{-4}		
Magnetic field intensity	Oersted	Oe	$10^3/4\pi$	Ampere per meter	A/m
Electric charge	Coulomb	C	1	Coulomb	C
	Electric potential difference	Volt	1		
Capacitance	Farad	F	1	Farad	F
	(Electric) Resistance	Ohm	1		
(Electric) Conductance	Siemens	S	1	Siemens	S
	Inductance	Henry	1		
Current	Ampere	A	1	Ampere	A

● Inch-mm Conversion Table

1 inch=25.4mm

inch		0"	1"	2"	3"	4"	5"	6"	7"	8"
Fractional number	Decimal number									
1 / 64"	0.015625	0.397	25.400	50.800	76.200	101.600	127.000	152.400	177.800	203.200
1 / 32"	0.031250	0.794	25.797	51.197	76.597	101.997	127.397	152.797	178.197	203.597
3 / 64"	0.046875	1.191	26.194	51.594	76.994	102.394	127.794	153.194	178.594	203.994
1 / 16"	0.062500	1.588	26.591	51.991	77.391	102.791	128.191	153.591	178.991	204.391
5 / 64"	0.078125	1.984	26.988	52.388	77.788	103.188	128.588	153.988	179.388	204.788
3 / 32"	0.093750	2.381	27.384	52.784	78.184	103.584	128.984	154.384	179.784	205.184
7 / 64"	0.109375	2.778	27.781	53.181	78.581	103.981	129.381	154.781	180.181	205.581
1 / 8"	0.125000	3.175	28.178	53.578	78.978	104.378	129.778	155.178	180.578	205.978
9 / 64"	0.140625	3.572	28.575	53.975	79.375	104.775	130.175	155.575	180.975	206.375
5 / 32"	0.156250	3.969	28.972	54.372	79.772	105.172	130.572	155.972	181.372	206.772
11 / 64"	0.171875	4.366	29.369	54.769	80.169	105.569	130.969	156.369	181.769	207.169
3 / 16"	0.187500	4.762	29.766	55.166	80.566	105.966	131.366	156.766	182.166	207.566
13 / 64"	0.203125	5.159	30.162	55.562	80.962	106.362	131.762	157.162	182.562	207.962
7 / 32"	0.218750	5.556	30.559	55.959	81.359	106.759	132.159	157.559	182.959	208.359
15 / 64"	0.234375	5.953	30.956	56.356	81.756	107.156	132.556	157.956	183.356	208.756
1 / 4"	0.250000	6.350	31.353	56.753	82.153	107.553	132.953	158.353	183.753	209.153
17 / 64"	0.265625	6.747	31.750	57.150	82.550	107.950	133.350	158.750	184.150	209.550
9 / 32"	0.281250	7.144	32.147	57.547	82.947	108.347	133.747	159.147	184.547	209.947
19 / 64"	0.296875	7.541	32.544	57.944	83.344	108.744	134.144	159.544	184.944	210.344
5 / 16"	0.312500	7.938	32.941	58.341	83.741	109.141	134.541	159.941	185.341	210.741
21 / 64"	0.328125	8.334	33.338	58.738	84.138	109.538	134.938	160.338	185.738	211.138
11 / 32"	0.343750	8.731	33.734	59.134	84.534	109.934	135.334	160.734	186.134	211.534
23 / 64"	0.359375	9.128	34.131	59.531	84.931	110.331	135.731	161.131	186.531	211.931
3 / 8"	0.375000	9.525	34.528	59.928	85.328	110.728	136.128	161.528	186.928	212.328
25 / 64"	0.390625	9.922	34.925	60.325	85.725	111.125	136.525	161.925	187.325	212.725
13 / 32"	0.406250	10.319	35.322	60.722	86.122	111.522	136.922	162.322	187.722	213.122
27 / 64"	0.421875	10.716	35.719	61.119	86.519	111.919	137.319	162.719	188.119	213.519
7 / 16"	0.437500	11.112	36.116	61.516	86.916	112.316	137.716	163.116	188.516	213.916
29 / 64"	0.453125	11.509	36.512	61.912	87.312	112.712	138.112	163.512	188.912	214.312
15 / 32"	0.468750	11.906	36.909	62.309	87.709	113.109	138.509	163.909	189.309	214.709
31 / 64"	0.484375	12.303	37.306	62.706	88.106	113.506	138.906	164.306	189.706	215.106
1 / 2"	0.500000	12.700	37.703	63.103	88.503	113.903	139.303	164.703	190.103	215.503
			38.100	63.500	88.900	114.300	139.700	165.100	190.500	215.900

1 inch=25.4mm

inch		0"	1"	2"	3"	4"	5"	6"	7"	8"
Fractional number	Decimal number									
33 / 64"	0.515625	13.097	38.497	63.897	89.297	114.697	140.097	165.497	190.897	216.297
17 / 32"	0.531250	13.494	38.894	64.294	89.694	115.094	140.494	165.894	191.294	216.694
35 / 64"	0.546875	13.891	39.291	64.691	90.091	115.491	140.891	166.291	191.691	217.091
9 / 16"	0.562500	14.288	39.688	65.088	90.488	115.888	141.288	166.688	192.088	217.488
37 / 64"	0.578125	14.684	40.084	65.484	90.884	116.284	141.684	167.084	192.484	217.884
19 / 32"	0.593750	15.081	40.481	65.881	91.281	116.681	142.081	167.481	192.881	218.281
39 / 64"	0.609375	15.478	40.878	66.278	91.678	117.078	142.478	167.878	193.278	218.678
5 / 8"	0.625000	15.875	41.275	66.675	92.075	117.475	142.875	168.275	193.675	219.075
41 / 64"	0.640625	16.272	41.672	67.072	92.472	117.872	143.272	168.672	194.072	219.472
21 / 32"	0.656250	16.669	42.069	67.469	92.869	118.269	143.669	169.069	194.469	219.869
43 / 64"	0.671875	17.066	42.466	67.866	93.266	118.666	144.066	169.466	194.866	220.266
11 / 16"	0.687500	17.462	42.862	68.262	93.662	119.062	144.462	169.862	195.262	220.662
45 / 64"	0.703125	17.859	43.259	68.659	94.059	119.459	144.859	170.259	195.659	221.059
23 / 32"	0.718750	18.256	43.656	69.056	94.456	119.856	145.256	170.656	196.056	221.456
47 / 64"	0.734375	18.653	44.053	69.453	94.853	120.253	145.653	171.053	196.453	221.853
3 / 4"	0.750000	19.050	44.450	69.850	95.250	120.650	146.050	171.450	196.850	222.250
49 / 64"	0.765625	19.447	44.847	70.247	95.647	121.047	146.447	171.847	197.247	222.647
25 / 32"	0.781250	19.844	45.244	70.644	96.044	121.444	146.844	172.244	197.644	223.044
51 / 64"	0.796875	20.241	45.641	71.041	96.441	121.841	147.241	172.641	198.041	223.441
13 / 16"	0.812500	20.638	46.038	71.438	96.838	122.238	147.638	173.038	198.438	223.838
53 / 64"	0.828125	21.034	46.434	71.834	97.234	122.634	148.034	173.434	198.834	224.234
27 / 32"	0.843750	21.431	46.831	72.231	97.631	123.031	148.431	173.831	199.231	224.631
55 / 64"	0.859375	21.828	47.228	72.628	98.028	123.428	148.828	174.228	199.628	225.028
7 / 8"	0.875000	22.225	47.625	73.025	98.425	123.825	149.225	174.625	200.025	225.425
57 / 64"	0.890625	22.622	48.022	73.422	98.822	124.222	149.622	175.022	200.422	225.822
29 / 32"	0.906250	23.019	48.419	73.819	99.219	124.619	150.019	175.419	200.819	226.219
59 / 64"	0.921875	23.416	48.816	74.216	99.616	125.016	150.416	175.816	201.216	226.616
15 / 16"	0.937500	23.812	49.212	74.612	100.012	125.412	150.812	176.212	201.612	227.012
61 / 64"	0.953125	24.209	49.609	75.009	100.409	125.809	151.209	176.609	202.009	227.409
31 / 32"	0.968750	24.606	50.006	75.406	100.806	126.206	151.606	177.006	202.406	227.806
63 / 64"	0.984375	25.003	50.403	75.803	101.203	126.603	152.003	177.403	202.803	228.203

● Hardness Conversion Table (Reference)

Rockwell C scale hardness Load 1471N HRC	Vickers hardness HV	Brinell hardness		Rockwell hardness		Shore hardness HS
		Standard ball	Tungsten Carbide ball	A scale	B scale	
				Load 588.4N Diamond circular cone	Load 980.7N Diameter 1/16in ball	
68	940	—	—	85.6	—	97
67	900	—	—	85.0	—	95
66	865	—	—	84.5	—	92
65	832	—	(739)	83.9	—	91
64	800	—	(722)	83.4	—	88
63	772	—	(705)	82.8	—	87
62	746	—	(688)	82.3	—	85
61	720	—	(670)	81.8	—	83
60	697	—	(654)	81.2	—	81
59	674	—	(634)	80.7	—	80
58	653	—	615	80.1	—	78
57	633	—	595	79.6	—	76
56	613	—	577	79.0	—	75
55	595	—	560	78.5	—	74
54	577	—	543	78.0	—	72
53	560	—	525	77.4	—	71
52	544	(500)	512	76.8	—	69
51	528	(487)	496	76.3	—	68
50	513	(475)	481	75.9	—	67
49	498	(464)	469	75.2	—	66
48	484	451	455	74.7	—	64
47	471	442	443	74.1	—	63
46	458	432	432	73.6	—	62
45	446	421	421	73.1	—	60
44	434	409	409	72.5	—	58
43	423	400	400	72.0	—	57
42	412	390	390	71.5	—	56
41	402	381	381	70.9	—	55
40	392	371	371	70.4	—	54
39	382	362	362	69.9	—	52

Rockwell C scale hardness Load 1471N HRC	Vickers hardness HV	Brinell hardness		Rockwell hardness		Shore hardness HS
		Standard ball	Tungsten Carbide ball	A scale	B scale	
				Load 588.4N Diamond circular cone	Load 980.7N Diameter 1/16in ball	
38	372	353	353	69.4	—	51
37	363	344	344	68.9	—	50
36	354	336	336	68.4	(109.0)	49
35	345	327	327	67.9	(108.5)	48
34	336	319	319	67.4	(108.0)	47
33	327	311	311	66.8	(107.5)	46
32	318	301	301	66.3	(107.0)	44
31	310	294	294	65.8	(106.0)	43
30	302	286	286	65.3	(105.5)	42
29	294	279	279	64.7	(104.5)	41
28	286	271	271	64.3	(104.0)	41
27	279	264	264	63.8	(103.0)	40
26	272	258	258	63.3	(102.5)	38
25	266	253	253	62.8	(101.5)	38
24	260	247	247	62.4	(101.0)	37
23	254	243	243	62.0	100.0	36
22	248	237	237	61.5	99.0	35
21	243	231	231	61.0	98.5	35
20	238	226	226	60.5	97.8	34
(18)	230	219	219	—	96.7	33
(16)	222	212	212	—	95.5	32
(14)	213	203	203	—	93.9	31
(12)	204	194	194	—	92.3	29
(10)	196	187	187	—	90.7	28
(8)	188	179	179	—	89.5	27
(6)	180	171	171	—	87.1	26
(4)	173	165	165	—	85.5	25
(2)	166	158	158	—	83.5	24
(0)	160	152	152	—	81.7	24

● Tolerances of Shaft Dimensions

Classification of diameter mm		b12		c12		d6		e6		e12		f5		f6		g5	
Above	Below	H	L	H	L	H	L	H	L	H	L	H	L	H	L	H	L
—	3	-140	-240	-60	-160	-20	-26	-14	-20	-14	-114	-6	-10	-6	-12	-2	-6
3	6	-140	-260	-70	-190	-30	-38	-20	-28	-20	-140	-10	-15	-10	-18	-4	-9
6	10	-150	-300	-80	-230	-40	-49	-25	-34	-25	-175	-13	-19	-13	-22	-5	-11
10	18	-150	-330	-95	-275	-50	-61	-32	-43	-32	-212	-16	-24	-16	-27	-6	-14
18	30	-160	-370	-110	-320	-65	-78	-40	-53	-40	-250	-20	-29	-20	-33	-7	-16
30	40	-170	-420	-120	-370	-80	-96	-50	-66	-50	-300	-25	-36	-25	-41	-9	-20
40	50	-180	-430	-130	-380												
50	65	-190	-490	-140	-440	-100	-119	-60	-79	-60	-360	-30	-43	-30	-49	-10	-23
65	80	-200	-500	-150	-450												
80	100	-220	-570	-170	-520	-120	-142	-72	-94	-72	-422	-36	-51	-36	-58	-12	-27
100	120	-240	-590	-180	-530												
120	140	-260	-660	-200	-600	-145	-170	-85	-110	-85	-485	-43	-61	-43	-68	-14	-32
140	160	-280	-680	-210	-610												
160	180	-310	-710	-230	-630												
180	200	-340	-800	-240	-700	-170	-199	-100	-129	-100	-560	-50	-70	-50	-79	-15	-35
200	225	-380	-840	-260	-720												
225	250	-420	-880	-280	-740												
250	280	-480	-1000	-300	-820	-190	-222	-110	-142	-110	-630	-56	-79	-56	-88	-17	-40
280	315	-540	-1060	-330	-850												
315	355	-600	-1170	-360	-930	-210	-246	-125	-161	-125	-695	-62	-87	-62	-98	-18	-43
355	400	-680	-1250	-400	-970												
400	450	-760	-1390	-440	-1070	-230	-270	-135	-175	-135	-765	-68	-95	-68	-108	-20	-47
450	500	-840	-1470	-480	-1110												

Classification of diameter mm		h12		js5		j5		js6		j6		j7		k5		k6	
Above	Below	H	L	H	L	H	L	H	L	H	L	H	L	H	L	H	L
—	3	0	-100	+2	-2	+2	-2	+3	-3	+4	-2	+6	-4	+4	0	+6	0
3	6	0	-120	+2.5	-2.5	+3	-2	+4	-4	+6	-2	+8	-4	+6	+1	+9	+1
6	10	0	-150	+3	-3	+4	-2	+4.5	-4.5	+7	-2	+10	-5	+7	+1	+10	+1
10	18	0	-180	+4	-4	+5	-3	+5.5	-5.5	+8	-3	+12	-6	+9	+1	+12	+1
18	30	0	-210	+4.5	-4.5	+5	-4	+6.5	-6.5	+9	-4	+13	-8	+11	+2	+15	+2
30	40	0	-250	+5.5	-5.5	+6	-5	+8	-8	+11	-5	+15	-10	+13	+2	+18	+2
40	50																
50	65	0	-300	+6.5	-6.5	+6	-7	+9.5	-9.5	+12	-7	+18	-12	+15	+2	+21	+2
65	80																
80	100	0	-350	+7.5	-7.5	+6	-9	+11	-11	+13	-9	+20	-15	+18	+3	+25	+3
100	120																
120	140	0	-400	+9	-9	+7	-11	+12.5	-12.5	+14	-11	+22	-18	+21	+3	+28	+3
140	160																
160	180																
180	200	0	-460	+10	-10	+7	-13	+14.5	-14.5	+16	-13	+25	-21	+24	+4	+33	+4
200	225																
225	250																
250	280	0	-520	+11.5	-11.5	+7	-16	+16	-16	+16	-16	+26	-26	+27	+4	+36	+4
280	315																
315	355	0	-570	+12.5	-12.5	+7	-18	+18	-18	+18	-18	+29	-28	+29	+4	+40	+4
355	400																
400	450	0	-630	+13.5	-13.5	+7	-20	+20	-20	+20	-20	+31	-32	+32	+5	+45	+5
450	500																

unit: μm

Classification of diameter mm		g6		h5		h6		h7		h8		h9		h10		h11	
Above	Below	H	L	H	L	H	L	H	L	H	L	H	L	H	L	H	L
—	3	-2	-8	0	-4	0	-6	0	-10	0	-14	0	-25	0	-40	0	-60
3	6	-4	-12	0	-5	0	-8	0	-12	0	-18	0	-30	0	-48	0	-75
6	10	-5	-14	0	-6	0	-9	0	-15	0	-22	0	-36	0	-58	0	-90
10	18	-6	-17	0	-8	0	-11	0	-18	0	-27	0	-43	0	-70	0	-110
18	30	-7	-20	0	-9	0	-13	0	-21	0	-33	0	-52	0	-84	0	-130
30	40	-9	-25	0	-11	0	-16	0	-25	0	-39	0	-62	0	-100	0	-160
40	50																
50	65	-10	-29	0	-13	0	-19	0	-30	0	-46	0	-74	0	-120	0	-190
65	80																
80	100	-12	-34	0	-15	0	-22	0	-35	0	-54	0	-87	0	-140	0	-220
100	120																
120	140	-14	-39	0	-18	0	-25	0	-40	0	-63	0	-100	0	-160	0	-250
140	160																
160	180																
180	200	-15	-44	0	-20	0	-29	0	-46	0	-72	0	-115	0	-185	0	-290
200	225																
225	250																
250	280	-17	-49	0	-23	0	-32	0	-52	0	-81	0	-130	0	-210	0	-320
280	315																
315	355	-18	-54	0	-25	0	-36	0	-57	0	-89	0	-140	0	-230	0	-360
355	400																
400	450	-20	-60	0	-27	0	-40	0	-63	0	-97	0	-155	0	-250	0	-400
450	500																

unit: μm

Classification of diameter mm		m5		m6		n5		n6		p6	
Above	Below	H	L	H	L	H	L	H	L	H	L
—	3	+6	+2	+8	+2	+8	+4	+10	+4	+12	+6
3	6	+9	+4	+12	+4	+13	+8	+16	+8	+20	+12
6	10	+12	+6	+15	+6	+16	+10	+19	+10	+24	+15
10	18	+15	+7	+18	+7	+20	+12	+23	+12	+29	+18
18	30	+17	+8	+21	+8	+24	+15	+28	+15	+35	+22
30	40	+20	+9	+25	+9	+28	+17	+33	+17	+42	+26
40	50										
50	65	+24	+11	+30	+11	+33	+20	+39	+20	+51	+32
65	80										
80	100	+28	+13	+35	+13	+38	+23	+45	+23	+59	+37
100	120										
120	140	+33	+15	+40	+15	+45	+27	+52	+27	+68	+43
140	160										
160	180										
180	200	+37	+17	+46	+17	+51	+31	+60	+31	+79	+50
200	225										
225	250										
250	280	+43	+20	+52	+20	+57	+34	+66	+34	+88	+56
280	315										
315	355	+46	+21	+57	+21	+62	+37	+73	+37	+98	+62
355	400										
400	450	+50	+23	+63	+23	+67	+40	+80	+40	+108	+68
450	500										

● Tolerances of Housing Hole Dimensions

Classification of diameter mm		B12		E7		E11		E12		F6		F7		G6		G7	
Above	Below	H	L	H	L	H	L	H	L	H	L	H	L	H	L	H	L
—	3	+ 240	+140	+ 24	+ 14	+ 74	+ 14	+114	+ 14	+ 12	+ 6	+ 16	+ 6	+ 8	+ 2	+12	+ 2
3	6	+ 260	+140	+ 32	+ 20	+ 95	+ 20	+140	+ 20	+ 18	+10	+ 22	+10	+12	+ 4	+16	+ 4
6	10	+ 300	+150	+ 40	+ 25	+115	+ 25	+175	+ 25	+ 22	+13	+ 28	+13	+14	+ 5	+20	+ 5
10	18	+ 330	+150	+ 50	+ 32	+142	+ 32	+212	+ 32	+ 27	+16	+ 34	+16	+17	+ 6	+24	+ 6
18	30	+ 370	+160	+ 61	+ 40	+170	+ 40	+250	+ 40	+ 33	+20	+ 41	+20	+20	+ 7	+28	+ 7
30	40	+ 420	+170	+ 75	+ 50	+210	+ 50	+300	+ 50	+ 41	+25	+ 50	+25	+25	+ 9	+34	+ 9
40	50	+ 430	+180														
50	65	+ 490	+190	+ 90	+ 60	+250	+ 60	+360	+ 60	+ 49	+30	+ 60	+30	+29	+10	+40	+10
65	80	+ 500	+200														
80	100	+ 570	+220	+107	+ 72	+292	+ 72	+422	+ 72	+ 58	+36	+ 71	+36	+34	+12	+47	+12
100	120	+ 590	+240														
120	140	+ 660	+260														
140	160	+ 680	+280	+125	+ 85	+335	+ 85	+485	+ 85	+ 68	+43	+ 83	+43	+39	+14	+54	+14
160	180	+ 710	+310														
180	200	+ 800	+340														
200	225	+ 840	+380	+146	+100	+390	+100	+560	+100	+ 79	+50	+ 96	+50	+44	+15	+61	+15
225	250	+ 880	+420														
250	280	+1000	+480	+162	+110	+430	+110	+630	+110	+ 88	+56	+108	+56	+49	+17	+69	+17
280	315	+1060	+540														
315	355	+1170	+600	+182	+125	+485	+125	+695	+125	+ 98	+62	+119	+62	+54	+18	+75	+18
355	400	+1250	+680														
400	450	+1390	+760	+198	+135	+535	+135	+765	+135	+108	+68	+131	+68	+60	+20	+83	+20
450	500	+1470	+840														

Classification of diameter mm		JS7		J7		K5		K6		K7		M6		M7		N6	
Above	Below	H	L	H	L	H	L	H	L	H	L	H	L	H	L	H	L
—	3	+ 5	- 5	+ 4	- 6	0	- 4	0	- 6	0	-10	- 2	- 8	-2	-12	- 4	-10
3	6	+ 6	- 6	+ 6	- 6	0	- 5	+2	- 6	+ 3	- 9	- 1	- 9	0	-12	- 5	-13
6	10	+ 7	- 7	+ 8	- 7	+1	- 5	+2	- 7	+ 5	-10	- 3	-12	0	-15	- 7	-16
10	18	+ 9	- 9	+10	- 8	+2	- 6	+2	- 9	+ 6	-12	- 4	-15	0	-18	- 9	-20
18	30	+10	-10	+12	- 9	+1	- 8	+2	-11	+ 6	-15	- 4	-17	0	-21	-11	-24
30	40	+12	-12	+14	-11	+2	- 9	+3	-13	+ 7	-18	- 4	-20	0	-25	-12	-28
40	50																
50	65	+15	-15	+18	-12	+3	-10	+4	-15	+ 9	-21	- 5	-24	0	-30	-14	-33
65	80																
80	100	+17	-17	+22	-13	+2	-13	+4	-18	+10	-25	- 6	-28	0	-35	-16	-38
100	120																
120	140																
140	160	+20	-20	+26	-14	+3	-15	+4	-21	+12	-28	- 8	-33	0	-40	-20	-45
160	180																
180	200																
200	225	+23	-23	+30	-16	+2	-18	+5	-24	+13	-33	- 8	-37	0	-46	-22	-51
225	250																
250	280	+26	-26	+36	-16	+3	-20	+5	-27	+16	-36	- 9	-41	0	-52	-25	-57
280	315																
315	355	+28	-28	+39	-18	+3	-22	+7	-29	+17	-40	-10	-46	0	-57	-26	-62
355	400																
400	450	+31	-31	+43	-20	+2	-25	+8	-32	+18	-45	-10	-50	0	-63	-27	-67
450	500																

unit: μm

Classification of diameter mm		H6		H7		H8		H9		H10		H11		JS6		J6	
Above	Below	H	L	H	L	H	L	H	L	H	L	H	L	H	L	H	L
—	3	+ 6	0	+10	0	+14	0	+ 25	0	+ 40	0	+ 60	0	+ 3	- 3	+ 2	-4
3	6	+ 8	0	+12	0	+18	0	+ 30	0	+ 48	0	+ 75	0	+ 4	- 4	+ 5	-3
6	10	+ 9	0	+15	0	+22	0	+ 36	0	+ 58	0	+ 90	0	+ 4.5	- 4.5	+ 5	-4
10	18	+11	0	+18	0	+27	0	+ 43	0	+ 70	0	+110	0	+ 5.5	- 5.5	+ 6	-5
18	30	+13	0	+21	0	+33	0	+ 52	0	+ 84	0	+130	0	+ 6.5	- 6.5	+ 8	-5
30	40																
40	50	+16	0	+25	0	+39	0	+ 62	0	+100	0	+160	0	+ 8	- 8	+10	-6
50	65																
65	80	+19	0	+30	0	+46	0	+ 74	0	+120	0	+190	0	+ 9.5	- 9.5	+13	-6
80	100																
100	120	+22	0	+35	0	+54	0	+ 87	0	+140	0	+220	0	+11	-11	+16	-6
120	140																
140	160	+25	0	+40	0	+63	0	+100	0	+160	0	+250	0	+12.5	-12.5	+18	-7
160	180																
180	200	+29	0	+46	0	+72	0	+115	0	+185	0	+290	0	+14.5	-14.5	+22	-7
200	225																
225	250	+32	0	+52	0	+81	0	+130	0	+210	0	+320	0	+16	-16	+25	-7
250	280																
280	315	+36	0	+57	0	+89	0	+140	0	+230	0	+360	0	+18	-18	+29	-7
315	355																
355	400	+40	0	+63	0	+97	0	+155	0	+250	0	+400	0	+20	-20	+33	-7
400	450																
450	500																

unit: μm

Classification of diameter mm		N7		P6		P7		R7		S7	
Above	Below	H	L	H	L	H	L	H	L	H	L
—	3	- 4	-14	- 6	-12	- 6	- 16	- 10	- 20	- 14	- 24
3	6	- 4	-16	- 9	-17	- 8	- 20	- 11	- 23	- 15	- 27
6	10	- 4	-19	-12	-21	- 9	- 24	- 13	- 28	- 17	- 32
10	18	- 5	-23	-15	-26	-11	- 29	- 16	- 34	- 21	- 39
18	30	- 7	-28	-18	-31	-14	- 35	- 20	- 41	- 27	- 48
30	40	- 8	-33	-21	-37	-17	- 42	- 25	- 50	- 34	- 59
40	50										
50	65	- 9	-39	-26	-45	-21	- 51	- 30	- 60	- 42	- 72
65	80										
80	100	-10	-45	-30	-52	-24	- 59	- 38	- 73	- 58	- 93
100	120										
120	140	-12	-52	-36	-61	-28	- 68	- 48	- 88	- 77	-117
140	160										
160	180										
180	200	-14	-60	-41	-70	-33	- 79	- 60	-106	-105	-151
200	225										
225	250										
250	280	-14	-66	-47	-79	-36	- 88	- 74	-126	-138	-190
280	315										
315	355	-16	-73	-51	-87	-41	- 98	- 87	-144	-169	-226
355	400										
400	450	-17	-80	-55	-95	-45	-108	-103	-166	-209	-272
450	500										

Model Code Index

Model code	Series name	Catalog name	Page	Model code	Series name	Catalog name	Page
B				LM...F AJ	Linear Bushing	RED	II-181
B				LM...F OP	Linear Bushing	RED	II-181
BG	Stroke Rotary Cage	RED	II-212	LM...F UU	Linear Bushing	RED	II-183
BK...A	Miniature Stroke Rotary Bushing	RED	II-207	LM...F UU AJ	Linear Bushing	RED	II-183
BSP...SL	Precision Linear Slide Unit	RED	II- 89	LM...F UU OP	Linear Bushing	RED	II-183
BSPG...SL	Precision Linear Slide Unit	RED	II- 91	LM...N	Linear Bushing	RED	II-167
BSR...SL	Precision Linear Slide Unit	RED	II- 93	LM...N AJ	Linear Bushing	RED	II-167
BSU...A	Linear Slide Unit	RED	II- 99	LM...N F	Linear Bushing	RED	II-181
BWU	High Rigidity Precision Linear Slide Unit	RED	II- 81	LM...N F AJ	Linear Bushing	RED	II-181
C				LM...N F OP	Linear Bushing	RED	II-181
C				LM...N F UU	Linear Bushing	RED	II-183
CRW	Crossed Roller Way	RED	II- 33	LM...N F UU AJ	Linear Bushing	RED	II-183
CRW...SL	Crossed Roller Way	RED	II- 33	LM...N F UU OP	Linear Bushing	RED	II-183
CRWG	Anti-Creep Cage Crossed Roller Way	RED	II- 27	LM...N OP	Linear Bushing	RED	II-167
CRWG...H	Anti-Creep Cage Crossed Roller Way H	RED	II- 31	LM...N UU	Linear Bushing	RED	II-171
CRWM	Crossed Roller Way	RED	II- 49	LM...N UU AJ	Linear Bushing	RED	II-171
CRWU	Crossed Roller Way Unit	RED	II- 63	LM...N UU OP	Linear Bushing	RED	II-171
CRWU...R	Crossed Roller Way Unit	RED	II- 67	LM...OP	Linear Bushing	RED	II-167
CRWU...RS	Crossed Roller Way Unit	RED	II- 71	LM...UU	Linear Bushing	RED	II-171
CRWUG	Anti-Creep Cage Crossed Roller Way Unit	RED	II- 61	LM...UU AJ	Linear Bushing	RED	II-171
F				LM...UU OP	Linear Bushing	RED	II-171
F				LMB	Linear Bushing	RED	II-179
FT	Flat Roller Cage	RED	II-231	LMB...AJ	Linear Bushing	RED	II-179
FT...N	Flat Roller Cage	RED	II-231	LMB...N	Linear Bushing	RED	II-179
FT...V	Flat Roller Cage	RED	II-231	LMB...N AJ	Linear Bushing	RED	II-179
FTW...A	Flat Roller Cage	RED	II-232	LMB...N OP	Linear Bushing	RED	II-179
FTW...VA	Flat Roller Cage	RED	II-232	LMB...OP	Linear Bushing	RED	II-179
G				LME	Linear Bushing	RED	II-175
G				LME...AJ	Linear Bushing	RED	II-175
GSN	Roller Way	RED	II-223	LME...F	Linear Bushing	RED	II-185
L				LME...F AJ	Linear Bushing	RED	II-185
L				LME...F OP	Linear Bushing	RED	II-185
LM	Linear Bushing	RED	II-167	LME...F UU	Linear Bushing	RED	II-187
LM...AJ	Linear Bushing	RED	II-167	LME...F UU AJ	Linear Bushing	RED	II-187
LM...F	Linear Bushing	RED	II-181	LME...F UU OP	Linear Bushing	RED	II-187
				LME...N	Linear Bushing	RED	II-175
				LME...N AJ	Linear Bushing	RED	II-175
				LME...N F	Linear Bushing	RED	II-185
				LME...N F AJ	Linear Bushing	RED	II-185

Note: BLUE denotes CAT-1560E, while RED denotes CAT-1561E.

Model Code Index

Model code	Series name	Catalog name	Page	Model code	Series name	Catalog name	Page
LME...N F OP	Linear Bushing	RED	II-185	LRXS	Linear Roller Way Super X	BLUE	II-209
LME...N F UU	Linear Bushing	RED	II-187	LRXSC	Linear Roller Way Super X	BLUE	II-209
LME...N F UU AJ	Linear Bushing	RED	II-187	LRXSG	Linear Roller Way Super X	BLUE	II-209
LME...N F UU OP	Linear Bushing	RED	II-187	LS	Stroke Ball Spline	RED	II-149
LME...N OP	Linear Bushing	RED	II-175	LSAG	Linear Ball Spline G	RED	II-123
LME...N UU	Linear Bushing	RED	II-177	LSAGF	Linear Ball Spline G	RED	II-127
LME...N UU AJ	Linear Bushing	RED	II-177	LSAGFL	Linear Ball Spline G	RED	II-127
LME...N UU OP	Linear Bushing	RED	II-177	LSAGFLT	Linear Ball Spline G	RED	II-127
LME...OP	Linear Bushing	RED	II-175	LSAGFT	Linear Ball Spline G	RED	II-127
LME...UU	Linear Bushing	RED	II-177	LSAGL	Linear Ball Spline G	RED	II-123
LME...UU AJ	Linear Bushing	RED	II-177	LSAGLT	Linear Ball Spline G	RED	II-123
LME...UU OP	Linear Bushing	RED	II-177	LSAGT	Linear Ball Spline G	RED	II-123
LMG	Linear Bushing G	RED	II-159	LSB	Block Type Linear Ball Spline	RED	II-141
LMGT	Linear Bushing G	RED	II-159	LSB...SL	Block Type Linear Ball Spline	RED	II-141
LMS	Miniature Linear Bushing	RED	II-192	LSBT	Block Type Linear Ball Spline	RED	II-141
LMS...F	Miniature Linear Bushing	RED	II-192	LST	Stroke Ball Spline	RED	II-149
LMS...F UU	Miniature Linear Bushing	RED	II-192	LWE	Linear Way E	BLUE	II- 75
LMS...UU	Miniature Linear Bushing	RED	II-192	LWE...Q	Low Decibel Linear Way E	BLUE	II- 75
LMSL	Miniature Linear Bushing	RED	II-192	LWE...SL	Linear Way E	BLUE	II- 75
LMSL...F	Miniature Linear Bushing	RED	II-192	LWEC	Linear Way E	BLUE	II- 75
LMSL...F UU	Miniature Linear Bushing	RED	II-192	LWEC...SL	Linear Way E	BLUE	II- 75
LMSL...UU	Miniature Linear Bushing	RED	II-192	LWEG	Linear Way E	BLUE	II- 75
LRWM	Linear Way Module	BLUE	II-245	LWEG...SL	Linear Way E	BLUE	II- 75
LRWX...B	Linear Roller Way X	BLUE	II-227	LWES	Linear Way E	BLUE	II- 83
LRWXH	Linear Roller Way X	BLUE	II-229	LWES...Q	Low Decibel Linear Way E	BLUE	II- 83
LRX	Linear Roller Way Super X	BLUE	II-191	LWES...SL	Linear Way E	BLUE	II- 83
LRXC	Linear Roller Way Super X	BLUE	II-191	LWESC	Linear Way E	BLUE	II- 83
LRXD	Linear Roller Way Super X	BLUE	II-199	LWESC...SL	Linear Way E	BLUE	II- 83
LRXD...SL	Linear Roller Way Super X	BLUE	II-199	LWESG	Linear Way E	BLUE	II- 83
LRXDC	Linear Roller Way Super X	BLUE	II-199	LWESG...SL	Linear Way E	BLUE	II- 83
LRXDC...SL	Linear Roller Way Super X	BLUE	II-199	LWET	Linear Way E	BLUE	II- 79
LRXDG	Linear Roller Way Super X	BLUE	II-199	LWET...Q	Low Decibel Linear Way E	BLUE	II- 79
LRXDG...SL	Linear Roller Way Super X	BLUE	II-199	LWET...SL	Linear Way E	BLUE	II- 79
LRXDL	Linear Roller Way Super X	BLUE	II-207	LWETC	Linear Way E	BLUE	II- 79
LRXG	Linear Roller Way Super X	BLUE	II-191	LWETC...SL	Linear Way E	BLUE	II- 79
LRXH	Linear Roller Way Super X	BLUE	II-191	LWETG	Linear Way E	BLUE	II- 79
LRXHC	Linear Roller Way Super X	BLUE	II-191	LWETG...SL	Linear Way E	BLUE	II- 79
LRXHG	Linear Roller Way Super X	BLUE	II-191	LWFF	Linear Way F	BLUE	II-151
LRXL	Linear Roller Way Super X	BLUE	II-197	LWFH	Linear Way F	BLUE	II-149

Note: BLUE denotes CAT-1560E, while RED denotes CAT-1561E.

Model Code Index

Model code	Series name	Catalog name	Page	Model code	Series name	Catalog name	Page
L							
LWFS	Linear Way F	BLUE	II-153	LWLF...BCS	Linear Way L	BLUE	II-35
LWFS...SL	Linear Way F	BLUE	II-153	LWLF...N	Linear Way L	BLUE	II-31
LWH...B	Linear Way H	BLUE	II-107	LWLFC	Linear Way L	BLUE	II-31
LWH...M	Linear Way H	BLUE	II-107	LWLFC...B	Linear Way L	BLUE	II-31
LWH...MU	Linear Way H	BLUE	II-107	LWLFC...N	Linear Way L	BLUE	II-31
LWH...SL	Linear Way H	BLUE	II-107	LWLFG...B	Linear Way L	BLUE	II-33
LWHD	Linear Way H	BLUE	II-121	LWLFG...N	Linear Way L	BLUE	II-33
LWHD...B	Linear Way H	BLUE	II-123	LWLG...B	Linear Way L	BLUE	II-25
LWHD...M	Linear Way H	BLUE	II-123	LWLG...N	Linear Way L	BLUE	II-25
LWHD...MU	Linear Way H	BLUE	II-123	LWLM	Linear Way Module	BLUE	II-241
LWHD...SL	Linear Way H	BLUE	II-121	LWM	Linear Way Module	BLUE	II-243
LWHDC...SL	Linear Way H	BLUE	II-121	LWU	Linear Way U	BLUE	II-167
LWHDG	Linear Way H	BLUE	II-123	LWU...B	Linear Way U	BLUE	II-167
LWHDG...SL	Linear Way H	BLUE	II-121	LWUL...B	Linear Way U	BLUE	II-167
LWHG	Linear Way H	BLUE	II-107	M			
LWHS...B	Linear Way H	BLUE	II-127	MAG	C-Lube Linear Ball Spline MAG	RED	II-123
LWHS...M	Linear Way H	BLUE	II-127	MAGF	C-Lube Linear Ball Spline MAG	RED	II-127
LWHS...MU	Linear Way H	BLUE	II-127	MAGFT	C-Lube Linear Ball Spline MAG	RED	II-127
LWHS...SL	Linear Way H	BLUE	II-127	MAGL	C-Lube Linear Ball Spline MAG	RED	II-123
LWHS	Linear Way H	BLUE	II-127	MAGLT	C-Lube Linear Ball Spline MAG	RED	II-123
LWHT	Linear Way H	BLUE	II-113	MAGT	C-Lube Linear Ball Spline MAG	RED	II-123
LWHT...B	Linear Way H	BLUE	II-113	ME	C-Lube Linear Way ME	BLUE	II-75
LWHT...M	Linear Way H	BLUE	II-113	ME...SL	C-Lube Linear Way ME	BLUE	II-75
LWHT...MU	Linear Way H	BLUE	II-113	MEC	C-Lube Linear Way ME	BLUE	II-75
LWHT...SL	Linear Way H	BLUE	II-113	MEC...SL	C-Lube Linear Way ME	BLUE	II-75
LWHTG	Linear Way H	BLUE	II-115	MEG	C-Lube Linear Way ME	BLUE	II-75
LWHY	Linear Way H	BLUE	II-131	MEG...SL	C-Lube Linear Way ME	BLUE	II-75
LWL	Linear Way L	BLUE	II-23	MES	C-Lube Linear Way ME	BLUE	II-83
LWL...B	Linear Way L	BLUE	II-25	MES...SL	C-Lube Linear Way ME	BLUE	II-83
LWL...B CS	Linear Way L	BLUE	II-27	MESC	C-Lube Linear Way ME	BLUE	II-83
LWL...N	Linear Way L	BLUE	II-25	MESC...SL	C-Lube Linear Way ME	BLUE	II-83
LWL...Y	Linear Way L	BLUE	II-23	MESG	C-Lube Linear Way ME	BLUE	II-83
LWLC	Linear Way L	BLUE	II-23	MESG...SL	C-Lube Linear Way ME	BLUE	II-83
LWLC...B	Linear Way L	BLUE	II-25	MET	C-Lube Linear Way ME	BLUE	II-79
LWLC...N	Linear Way L	BLUE	II-25	MET...SL	C-Lube Linear Way ME	BLUE	II-79
LWLF	Linear Way L	BLUE	II-31	METC	C-Lube Linear Way ME	BLUE	II-79
LWLF...B	Linear Way L	BLUE	II-31	METC...SL	C-Lube Linear Way ME	BLUE	II-79

Note: BLUE denotes CAT-1560E, while RED denotes CAT-1561E.

Model Code Index

Model code	Series name	Catalog name	Page	Model code	Series name	Catalog name	Page
METG	C-Lube Linear Way ME	BLUE	II-79	MXDC	C-Lube Linear Roller Way Super MX	BLUE	II-199
METG...SL	C-Lube Linear Way ME	BLUE	II-79	MXDG	C-Lube Linear Roller Way Super MX	BLUE	II-199
MH	C-Lube Linear Way MH	BLUE	II-107	MXDL	C-Lube Linear Roller Way Super MX	BLUE	II-201
MH...M	C-Lube Linear Way MH	BLUE	II-107	MXG	C-Lube Linear Roller Way Super MX	BLUE	II-191
MH...MU	C-Lube Linear Way MH	BLUE	II-107	MXH	C-Lube Linear Roller Way Super MX	BLUE	II-191
MHD	C-Lube Linear Way MH	BLUE	II-121	MXHC	C-Lube Linear Roller Way Super MX	BLUE	II-191
MHD...M	C-Lube Linear Way MH	BLUE	II-123	MXHG	C-Lube Linear Roller Way Super MX	BLUE	II-191
MHD...MU	C-Lube Linear Way MH	BLUE	II-123	MXHL	C-Lube Linear Roller Way Super MX	BLUE	II-191
MHD...SL	C-Lube Linear Way MH	BLUE	II-121	MXL	C-Lube Linear Roller Way Super MX	BLUE	II-191
MHDC...SL	C-Lube Linear Way MH	BLUE	II-121	MXN	C-Lube Linear Roller Way Super MX	BLUE	II-213
MHDG	C-Lube Linear Way MH	BLUE	II-123	MXNG	C-Lube Linear Roller Way Super MX	BLUE	II-213
MHDG...SL	C-Lube Linear Way MH	BLUE	II-121	MXNL	C-Lube Linear Roller Way Super MX	BLUE	II-213
MHDL	C-Lube Linear Way MH	BLUE	II-123	MXNS	C-Lube Linear Roller Way Super MX	BLUE	II-215
MHG	C-Lube Linear Way MH	BLUE	II-107	MXNSG	C-Lube Linear Roller Way Super MX	BLUE	II-215
MHS	C-Lube Linear Way MH	BLUE	II-127	MXNSL	C-Lube Linear Roller Way Super MX	BLUE	II-215
MHS...M	C-Lube Linear Way MH	BLUE	II-129	MXS	C-Lube Linear Roller Way Super MX	BLUE	II-209
MHS...MU	C-Lube Linear Way MH	BLUE	II-129	MXSC	C-Lube Linear Roller Way Super MX	BLUE	II-209
MHS...SL	C-Lube Linear Way MH	BLUE	II-127	MXSG	C-Lube Linear Roller Way Super MX	BLUE	II-209
MHSG	C-Lube Linear Way MH	BLUE	II-127	MXSL	C-Lube Linear Roller Way Super MX	BLUE	II-209
MHT	C-Lube Linear Way MH	BLUE	II-113	O			
MHT...M	C-Lube Linear Way MH	BLUE	II-115	OR...A	Miniature Stroke Rotary Bushing	RED	II-207
MHT...MU	C-Lube Linear Way MH	BLUE	II-115	R			
MHT...SL	C-Lube Linear Way MH	BLUE	II-113	RW	Roller Way	RED	II-221
MHTG	C-Lube Linear Way MH	BLUE	II-113	RWB	Roller Way	RED	II-222
MHTL	C-Lube Linear Way MH	BLUE	II-117	S			
ML	C-Lube Linear Way ML	BLUE	II-25	SF...A	Miniature Stroke Rotary Bushing	RED	II-207
MLC	C-Lube Linear Way ML	BLUE	II-25	SR	Roller Way	RED	II-223
MLF	C-Lube Linear Way ML	BLUE	II-31	ST	Stroke Rotary Bushing	RED	II-199
MLFC	C-Lube Linear Way ML	BLUE	II-31	ST...B	Stroke Rotary Bushing	RED	II-199
MLFG	C-Lube Linear Way ML	BLUE	II-33	ST...UU	Stroke Rotary Bushing	RED	II-201
MLG	C-Lube Linear Way ML	BLUE	II-25	ST...UU B	Stroke Rotary Bushing	RED	II-201
MLL	C-Lube Linear Way ML	BLUE	II-27	STS	Miniature Stroke Rotary Bushing	RED	II-207
MLV	C-Lube Linear Way MLV	BLUE	II-47	STSI	Miniature Stroke Rotary Bushing	RED	II-207
MUL	C-Lube Linear Way MUL	BLUE	II-167				
MV	C-Lube Linear Way MV	BLUE	II-59				
MX	C-Lube Linear Roller Way Super MX	BLUE	II-191				
MXC	C-Lube Linear Roller Way Super MX	BLUE	II-191				
MXD	C-Lube Linear Roller Way Super MX	BLUE	II-199				
MXD...SL	C-Lube Linear Roller Way Super MX	BLUE	II-199				

Note: BLUE denotes CAT-1560E, while RED denotes CAT-1561E.

IKO Linear Motion Rolling Guide Series,

Configuration of General Catalog

IKO Linear Motion Rolling Guide Series General Catalog Consists of **BLUE** (CAT-1560E) and

RED (CAT-1561E), the two volumes.

BLUE



CAT-1560E

【Models】

- Rail Guide Type
- Endless Linear Motion Type

C-Lube Linear Way ML Linear Way L C-Lube Linear Way MLV C-Lube Linear Way MV Linear Way E C-Lube Linear Way ME Linear Way H C-Lube Linear Way MH

ML · LWL



MLV

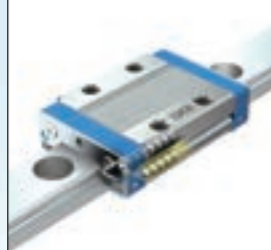

MV



ME · LWE



MH · LWH



Linear Way F

LWF



C-Lube Linear Way MUL Linear Way U

MUL · LWU

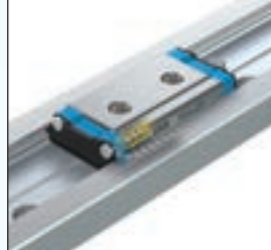

C-Lube Linear Roller Way Super MX Linear Roller Way Super X

MX · LRX



Linear Roller Way X

LRWX



Linear Way Module

LWLM · LWM
LRWM



RED

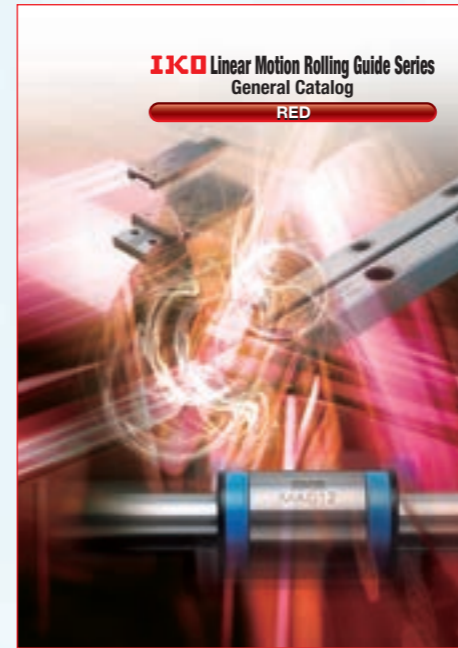

CAT-1561E

【Models】

- Rail Guide Type Limited Linear Motion Type
- Shaft Guide Type Endless Linear Motion Type Limited Linear Motion Type Limited Linear Motion Type + Rolling Motion Type
- Flat Guide Type Endless Linear Motion Type Limited Linear Motion Type

Rail Guide Type Crossed Roller Way

CRW(G)(···H)
CRWU(G)



Rail Guide Type Linear Slide Unit

BWU · BSP(G)
BSU···A



Shaft Guide Type Linear Ball Spline

MAG · LSAG
LSB · LS



Shaft Guide Type Linear Bushing

LMG · LM · LMS



Shaft Guide Type Stroke Rotary Bushing

ST · STSI · BG



Flat Guide Type Roller Way & Flat Roller Cage

RW · SR · GSN
FT · FTW···A



IKO Introduction of Technical Service Site

"IKO Technical Service Site" can be accessed from our home page **IKO**. The site also distributes various tools, etc., to select Linear ways/Linear roller ways, and please utilize the site for the assistance to select products. Additionally the site also provides CAD data and product catalog of needle series, linear motion rolling guide series and mechatronics series for you to download. Please consider to use for enhancing your design efficiency.

<http://www.ikont.co.jp/eg/>

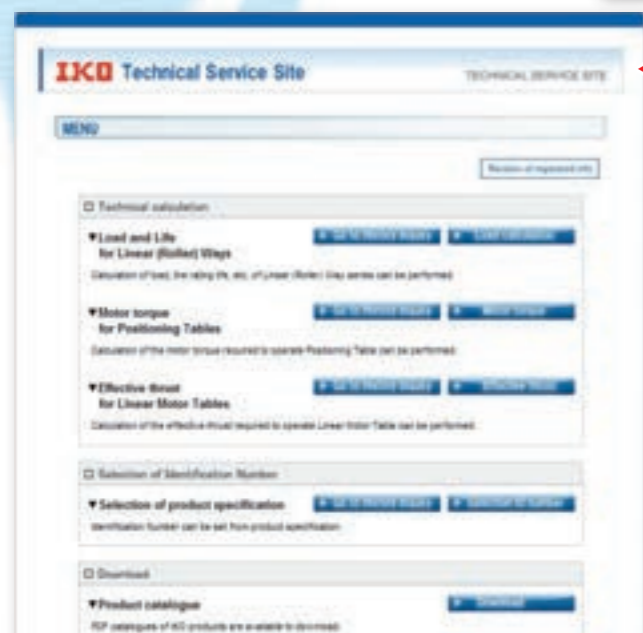

1. Technical calculations

For Linear Way/Roller Way load and life calculation, you can obtain the calculated load and the rating life by entering the operating conditions. Also you can derive the motor torque required for operation and the effective thrust force during operation in the sections of motor torque calculation and calculation of effective thrust force of linear motor tables respectively, and output the calculation results in PDF format, as well as save the histories.

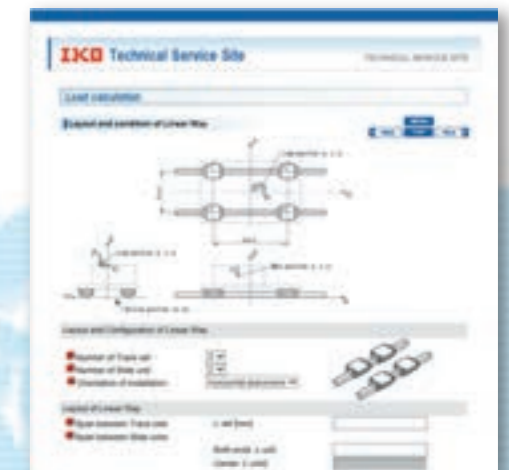

2. Selection of Identification Number

By selecting such specification as model code, dimensions, part code, material code, preload symbol, classification symbol, interchangeable code and supplemental code of Linear ways/Linear roller ways, you can easily specify the identification number used for ordering.

Also you can browse the CAD data of the selected products, calculate the load, and output the selection results in PDF format, as well as save the histories.



3. Downloading CAD data

2-dimensional CAD data (DXF file)

There are two types of figures, brief figure and detailed figure. The brief figure shows only the external view lines, and the detailed figure shows the detailed lines. The drawing consists of three drawings: front view, side view and plain view. The scale shows only the original size (1:1), and it does not show dimension lines.



3-dimensional CAD data

It is linked to the mechanical parts CAD library "PART community". Entering the rail dimension and option contents to the detail, you can view the 2D/3D CAD data suitable for the specification for free of charge.



4. Downloading Catalog and Operation Manual

You can download product catalogs of needle series, linear motion rolling guide series and mechatronics series, operation manuals of precision positioning tables and various electrical components in PDF format, as well as support software for precision positioning tables. If you would like a copy of our catalog, please visit the **IKO** official website and apply for the catalog, or contact our regional office or sales office nearby.

Oil Minimum

IKO Gentle to The Earth

Nippon Thompson Co., Ltd. is working to develop global environment-friendly products.

It is committed to developing products that make its customers' machinery and equipment more reliable, thereby contributing to preserving the global environment.

This development stance manifests well in the keyword "Oil Minimum."

Our pursuit of Oil Minimum has led to the creation of
IKO's proprietary family of lubricating parts as "C-Lube."

IKO Products Underpin Sustain Technology Leaps

Nippon Thompson Co., Ltd. was the first Japanese manufacturer to develop needle bearings on its own and has since expanded into the arena of linear motion rolling guides (Linear Motion Series and Mechatro Series) on the support of its advanced expertise. The company now offers a vast assortment of ingenious products, including the world's first C-Lube maintenance-free series, to address increasingly diversified customer needs and thus sustain technology leaps.

C-Lube Maintenance-Free Series Products Evolving from the "Oil Minimum" Concept

We have developed lubricating parts impregnated with a large amount of lubricant as C-Lube Series to save the customer's oiling management workload and built them into bearings and linear motion rolling guides. The C-Lube Series not only keeps products maintenance-free for long by giving them an optimal and minimal amount of a lubricant for an extended period of time but also contributes greatly to preserving the global environment.

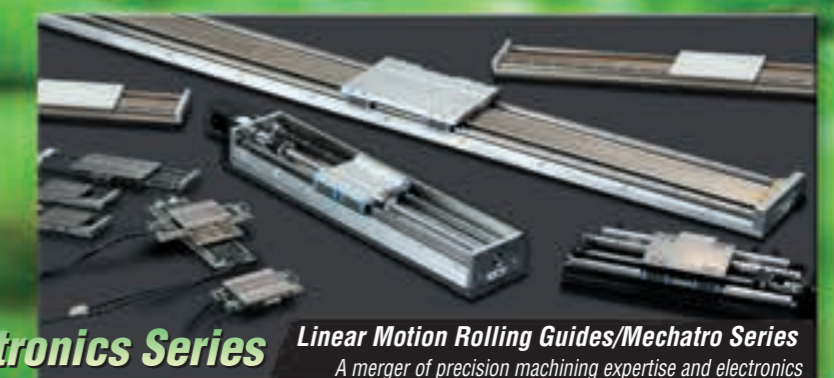

- **IKO** Linear Motion Rolling Guides are manufactured through a control system that alleviates their impact on the global environment to meet the quality requirements of ISO 14001 in compliance with the quality requirements level of ISO 9001 for quality improvement.
- The standard products listed in this catalog comply with the specifications of the six hazardous materials mentioned cited in the European RoHS Directive.